

# SG12864H ( 128 DOTS X 64 DOTS )

## FEATURES

- ◆ BUILT-IN CONTROLLER (KS0107 OR EQUIVALENT)
- ◆ +5 V POWER SUPPLY
- ◆ 1/64 DUTY CYCLE
- ◆ 8-BIT PARALLEL INTERFACE

## MECHANICAL DATA

ITEM	DIMENSIONS	UNIT
Module Size ( W x H x T )	75.0 x 52.7 x 7.9 ( 9.2 LED )	mm
Viewing Area ( W x H )	60.0 x 32.5	mm
Active Area ( W x H )	55.01 x 27.49	mm
Dot Size ( W x H )	0.40 x 0.40	mm
Dot Pitch ( W x H )	0.43 x 0.43	mm

## INTERFACE PIN CONNECTIONS

NO.	SYMBOL	LEVEL	FUNCTION
1	V <sub>DD</sub>	5V	Power Supply Voltage
2	V <sub>SS</sub>	0V	Power Supply Ground
3	V <sub>o</sub>	-	Contrast Adjustment Voltage
4~11	DB0~DB7	H/L	Data Bus Line
12	CS1	H	Chip Select Signal For IC1
13	CS2	H	Chip Select Signal For IC2
14	/RES	L	Reset Signal
15	R/W	H/L	H : Read / L : Write
16	D/I	H/L	L : Data, H : Instruction Code
17	E	H→L	Enable Signal
18	V <sub>out</sub>	-	Power Supply Voltage For LCD
19	A	4.2V	LED Power (+)
20	K	0V	LED Power (-)

## ABSOLUTE MAXIMUM RATINGS

ITEM	SYMBOL	MIN.	TYP.	MAX.	UNIT
Supply Voltage For Logic	V <sub>DD</sub> -V <sub>SS</sub>	0	-	7	V
Supply Voltage For LCD Drive	V <sub>DD</sub> -V <sub>o</sub>	0	-	18	V
Input Voltage	V <sub>I</sub>	V <sub>SS</sub>	-	V <sub>DD</sub>	V

## ELECTRICAL CHARACTERISTICS

ITEM	SYMBOL	CONDITION	MIN.	TYP.	MAX.	UNIT	
Supply Voltage For Logic	V <sub>DD</sub> -V <sub>SS</sub>	-	4.5	5	5.5	V	
Supply Voltage For LCD	V <sub>DD</sub> -V <sub>o</sub>	V <sub>DD</sub> =5V Ta=25°C	7.8	8.6	9.2	V	
Supply Current	I <sub>DD</sub>	V <sub>DD</sub> =5V	-	6.2	10	mA	
Input Voltage	"HIGH" Level	V <sub>IH</sub>	-	2.2	-	V <sub>DD</sub>	V
	"LOW" Level	V <sub>IL</sub>	-	-	-	0.6	V
Output Voltage	"HIGH" Level	V <sub>OH</sub>	-	2.4	-	V	V
	"LOW" Level	V <sub>OL</sub>	-	-	-	0.4	V

## EXTERNAL DIMENSIONS

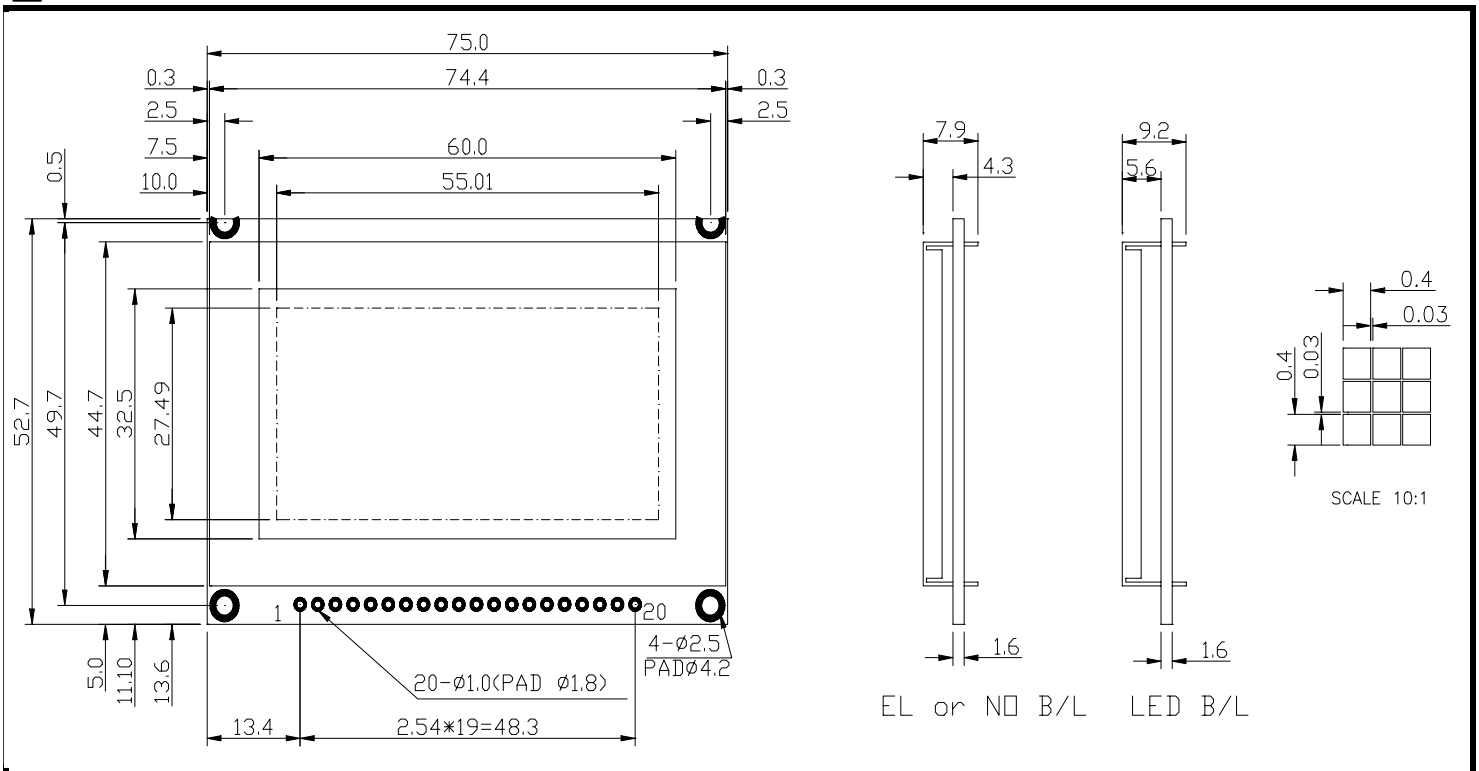

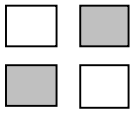

# SG12864H ( 128 DOTS X 64 DOTS )

## TIMING CHARACTERISTICS

ITEM	SYMBOL	MIN.	TYP.	MAX.	UNIT.	FIG
E Cycle Time	$t_{CYC}$	1000	-	-	ns	1,2
E High Level Width	$P_{WEH}$	450	-	-	ns	1,2
E Low Level Width	$P_{WEL}$	450	-	-	ns	1,2
E Rise Time	$t_r$	-	-	25	ns	1,2
E Fall Time	$t_f$	-	-	25	ns	1,2
Address Setup Time	$t_{AS}$	140	-	-	ns	1,2
Address Hold Time	$t_{AH}$	10	-	-	ns	1,2
Data Setup Time	$t_{DSW}$	200	-	-	ns	1
Data Delay Time	$t_{DDR}$	-	-	320	ns	2
Data Hold Time	Write	$t_{DHW}$	10	-	ns	1
Data Hold Time	Read	$t_{DHR}$	20	-	ns	2

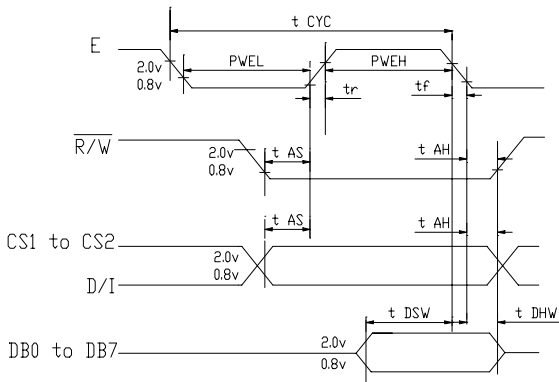

Fig1:CPU Write Timing

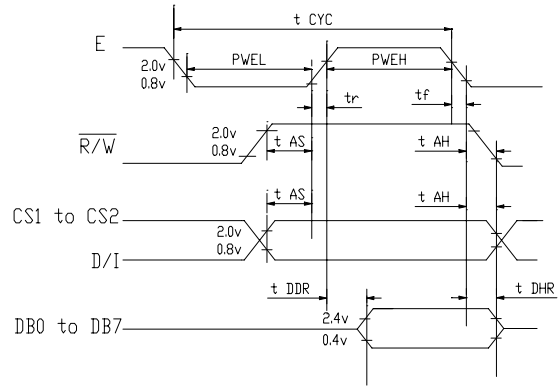

Fig2:CPU Read Timing

## BLOCK DIAGRAM

