

SG240128B (240 DOTS X 128 DOTS)

FEATURES

- ◆ BUILT-IN CONTROLLER (T6963C OR EQUIVALENT)
- ◆ +5 V POWER SUPPLY
- ◆ 1/128 DUTY CYCLE
- ◆ 8-BIT PARALLEL INTERFACE

MECHANICAL DATA

ITEM	DIMENSIONS	UNIT
Module Size (W x H x T)	144.0 x 104.0 x 10.3 (15.1 LED)	mm
Viewing Area (W x H)	114.0 x 64.0	mm
Active Area (W x H)	107.95 x 57.55	mm
Dot Size (W x H)	0.40 x 0.40	mm
Dot Pitch (W x H)	0.45 x 0.45	mm

INTERFACE PIN CONNECTIONS

NO.	SYMBOL	LEVEL	FUNCTION
1	V _{SS}	0V	Power Supply Ground
2	V _{DD}	5V	Power Supply Voltage
3	V ₀	-	Contrast Adjustment Voltage
4	C/D	H/L	H : Instruction Code, L : Data Code
5	/RD	L	Read Signal
6	/WR	L	Write Signal
7-14	DB0-DB7	H/L	Data Bus Line
15	/CE	L	Enable Signal
16	/RST	L	Reset Signal
17	V _{EE}	-	Power Supply Voltage For LCD
18	MD	H/L	H : 32 / L : 40 Select Of Columns
19	FS	H/L	H : 6*8 , L : 8*8 Select Of Columns
20	NC	-	No Connection

ABSOLUTE MAXIMUM RATINGS

ITEM	SYMBOL	MIN.	TYP.	MAX.	UNIT
Supply Voltage For Logic	V _{DD} -V _{SS}	0	-	7	V
Supply Voltage For LCD Drive	V _{DD} -V ₀	0	-	28	V
Input Voltage	V _I	V _{SS}	-	V _{DD}	V

ELECTRICAL CHARACTERISTICS

ITEM	SYMBOL	CONDITION	MIN.	TYP.	MAX.	UNIT	
Supply Voltage For Logic	V _{DD} -V _{SS}	-	4.5	5	5.5	V	
LCD Supply Voltage	V _{DD} -V ₀	V _{DD} =5V Ta=25°C	16.9	18	19.2	V	
Supply Current	I _{DD}	V _{DD} =5V	-	15	24	mA	
Input Voltage	"HIGH" Level	V _{IH}	-	2.2	-	V _{DD}	V
	"LOW" Level	V _{IL}	-	-	-	0.6	V
Output Voltage	"HIGH" Level	V _{OH}	-	2.4	-	-	V
	"LOW" Level	V _{OL}	-	-	-	0.4	V

EXTERNAL DIMENSIONS

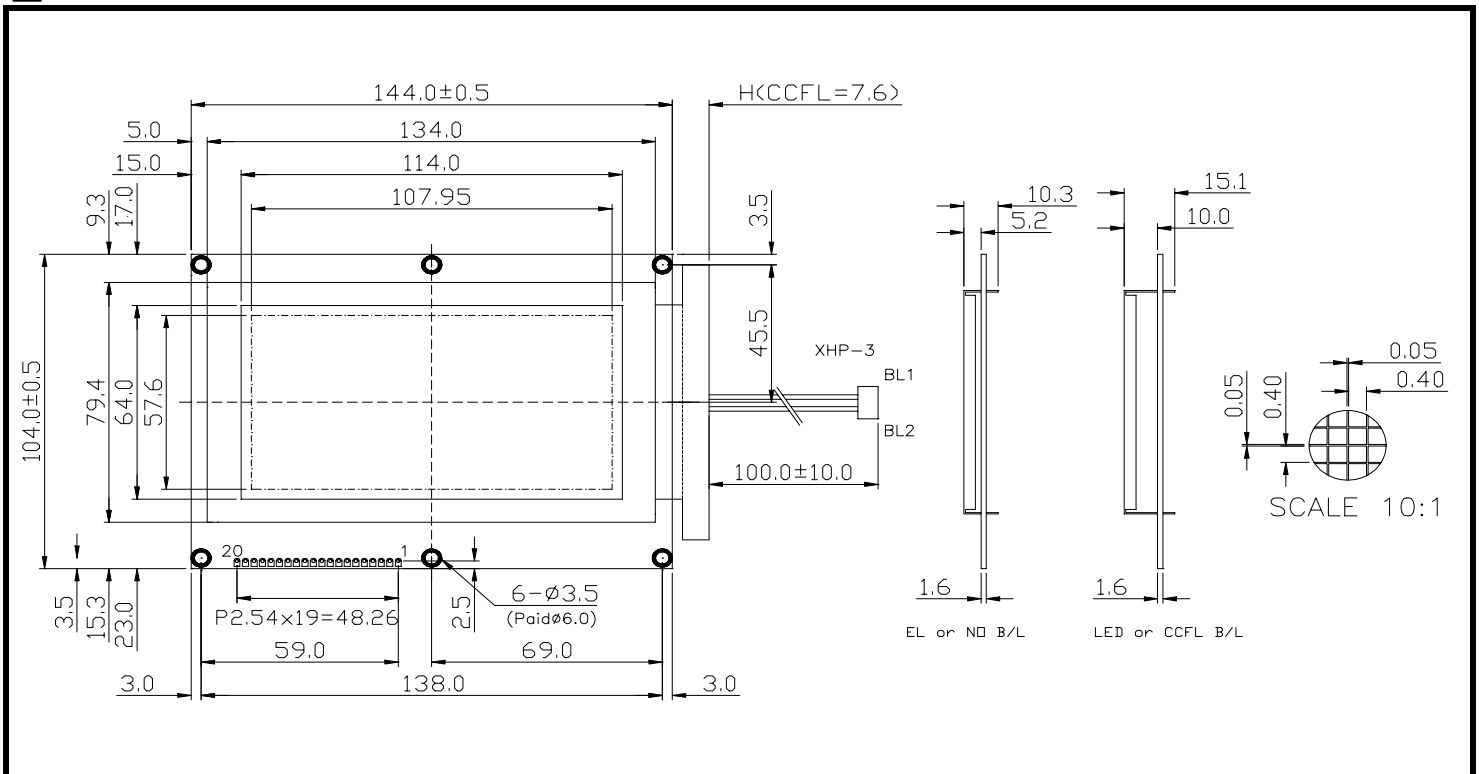

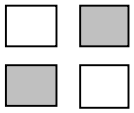

SG240128B (240 DOTS X 128 DOTS)

TIMING CHARACTERISTICS

ITEM	SYMBOL	MIN.	MAX.	UNIT.
C/D Setup Time	t_{CDS}	100	-	ns
C/D Hold Time	t_{CDH}	10	-	ns
CE, RD,WR Pulse Width	t_{CE}, t_{RD}, t_{WR}	80	-	ns
Data Setup Time	t_{DS}	80	-	ns
Data Hold Time	t_{DH}	40	-	ns
Access Time	t_{ACC}	-	150	ns
Output Hold Time	t_{OH}	10	50	ns

Bus Timing

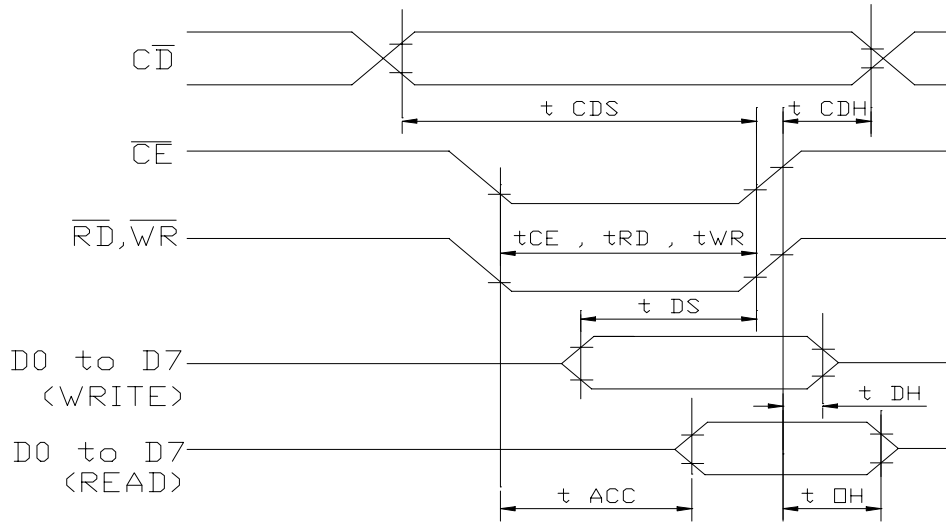

BLOCK DIAGRAM

