



# Specification for Approval

Customer: \_\_\_\_\_

Model Name: \_\_\_\_\_

Supplier Approval			Customer approval
R&D Designed	R&D Approved	QC Approved	
<i>Peter</i>	Peng Jun		



## Table of Contents

List	Description	Page No.
	Cover	1
	Revision Record	2
	Table of Contents	3
1	Scope	4
2	General Information	4
3	External Dimensions	5
4	Interface Description	6
5	Absolute Maximum Ratings	7
6	Electrical Characteristics	7
7	Timing Characteristics	8
8	Backlight Characteristics	9
9	Optical Characteristics	10
10	Reliability Test Conditions and Methods	12
11	Inspection Standard	13
12	Handling Precautions	17
13	Precaution for Use	18
14	Packing Method	18

## 1. Scope

This specification defines general provisions as well as inspection standards for TFT module supplied by AMSON electronics.

If the event of unforeseen problem or unspecified items may occur, naturally shall negotiate and agree to solution

## 2. General Information

ITEM	STANDARD VALUES	UNITS
LCD type	3.2" TFT	--
Dot arrangement	240(RGB) × 320	dots
Color filter array	RGB vertical stripe	--
Display mode	TN / Transmission / Normally White	--
Viewing Direction	12 O'clock (Gray inversion)	--
Driver IC	ILI9341	--
Module size	56.64(W) × 79.3(H) × 2.45(T)	mm
Active area	48.6(W) × 64.8(H)	mm
Dot pitch	0.2025(W) × 0.2025(H)	mm
Interface	i80-system 8/9/16-bit MCU interface / SPI	--
Operating temperature	-20 ~ +70	°C
Storage temperature	-30 ~ +80	°C
Back Light	5 White LED	--
Weight	TBD	g

## RTP

ITEM	STANDARD VALUES	UNITS
RTP type	Film + Glass + FPC	--
Surface hardness	3H	--
Transmittance	≥80%	--
RTP size	54.44(W) × 77.30 (H) × 1.15(T)	mm
Active area	49.20(W) × 65.40 (H)	mm
Response Time	≤10ms	ms
Response Time	≤1.5%	%
Hitting Life	≥1000000times	Times
Insulation resistance	>20MΩ	MΩ
Operation force	≤120g	g
Resistance	X:300Ω ~ 900Ω Y:200Ω ~ 600Ω	Ω

## 3. External Dimensions

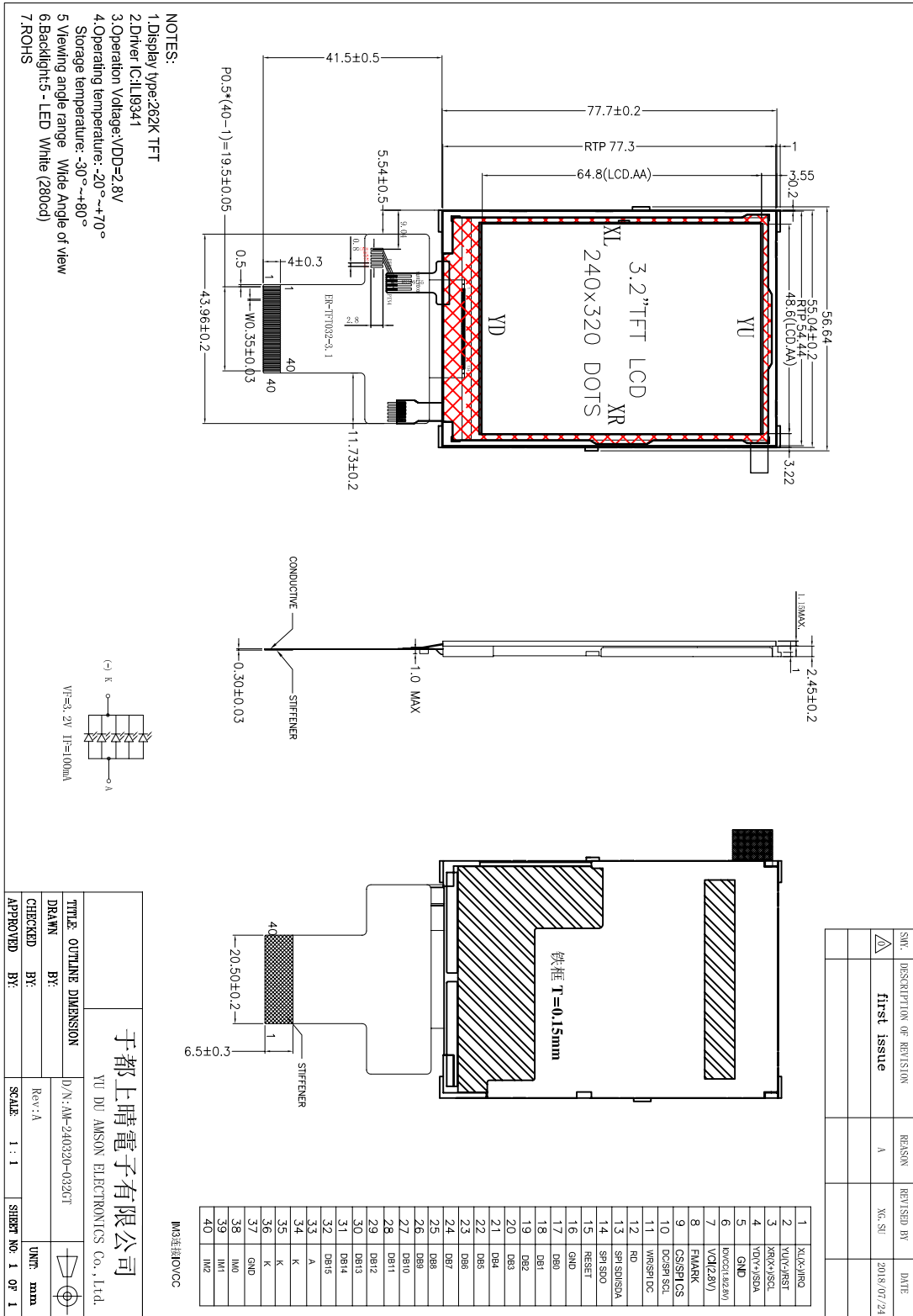

于都上晴电子有限公司		YU DU AMSON ELECTRONICS CO., LTD.	
TITLE: OUTLINE DIMENSION	Rev: A	SCALE: 1 : 1	SHEET NO. 1 OF 1
DRAWN BY:	Rev: A		
CHECKED BY:			
APPROVED BY:			

## 4. Interface Description

PIN NO.	PIN NAME	DESCRIPTION
1	XL(X-)	X Left
2	YU(Y-)	Y Up
3	XR(X+)	X Right
4	YD(Y+)	Y Down
5	GND	Ground
6	IOVCC(1.8/2.8V)	Logic operating voltage
7	VCI(2.8V)	Analog operating voltage
8	FMARK	Tearing effect signal is used to synchronize MCU to frame memory.
9	CS/SPI CS	Chip select input pin . note1,2
10	DC/SPI SCL	This pin is used to select "Data or Command" in the parallel interface or 4-wire 8-bit serial data interface. When DC = '1', data is selected. When DC = '0', command is selected. This pin is used serial interface clock in 3-wire 9-bit / 4-wire 8-bit serial data interface.
11	WR/SPI DC	WR: Serves as a read signal and MCU read data at the rising edge. SPI DC: Serves as command or parameter select.
12	RD	Read enable pin I80 parallel bus system interface
13	SPI SDI/SDA	Serial input signal.
14	SPI SDO	Serial output signal.
15	RESET	Reset pin. Initializes the IC. When this signal is low. Must be reset after power is stable.
16	GND	Ground
17	DB0	Data Bus
18	DB1	Data Bus
19	DB2	Data Bus
20	DB3	Data Bus
21	DB4	Data Bus
22	DB5	Data Bus
23	DB6	Data Bus
24	DB7	Data Bus
25	DB8	Data Bus

26	DB9	Data Bus									
27	DB10	Data Bus									
28	DB11	Data Bus									
29	DB12	Data Bus									
30	DB13	Data Bus									
31	DB14	Data Bus									
32	DB15	Data Bus									
33	A	LED backlight (Anode)									
34	K	LED backlight (Cathode)									
35	K	LED backlight (Cathode)									
36	K	LED backlight (Cathode)									
37	GND	Ground									
38	IM0	IM2	IM1	IM0	MCU-interface mode	DB PIN					
						Register/Content	Gram				
39	IM1	0	0	0	80 MCU 16-bit bus interface II	D[8:1]	D[17:10] D[8:1]				
						0	1	1	80 MCU 8-bit bus interface II	D[17:10]	D[17:10]
										0	1
40	IM2	1	0	1	3-wire 9bit data serial interface II	SDI:in,SDO:out					
						1	1	0	4-wire 8bit data serial interface II	SDI:in,SDO:out	

**Note.**

1. If CS is connected to VSS in Parallel interface mode, there will be no abnormal visible effect to the display module.

Also there will be no restriction on using the Parallel Read/Write protocols, Power On/Off Sequences or other functions.

Furthermore there will be no influence to the Power Consumption of the display module.

2. When CS='1', there is no influence to the parallel and serial interface.

## 5. Absolute Maximum Ratings

Item	Symbol	Min.	Max.	Unit
Logic Supply Voltage	IOVCC	-0.3	4.6	V
Analog Supply Voltage	VCI	-0.3	4.6	V
Input Voltage	Vin	-0.3	IOVCC+0.3	V
Operating Temperature	TOP	-20	70	°C
Storage Temperature	TST	-30	80	°C
Storage Humidity	HD	20	90	%RH

## 6. DC Characteristics

Item	Symbol	Min.	Typ.	Max.	Unit	Remark
Logic Supply Voltage	IOVCC	1.65	2.8	3.3	V	-
Analog Supply Voltage	VCI	2.5	2.8	3.3	V	-
Input High Voltage	V <sub>IH</sub>	0.7 VCC	-	VCC	V	-
Input Low Voltage	V <sub>IL</sub>	GND	-	0.3 VCC	V	-
Output High Voltage	V <sub>OH</sub>	0.8 VCC	-	VCC	V	-
Output Low Voltage	V <sub>OL</sub>	GND	-	0.2 VCC	V	-
I/O Leak Current	ILI	-1	-	1	uA	-

### NOTE:

Measuring Condition : Standard Value MAX.

Ta = 25°C

IOVCC-VSS = +2.8V

VCI-VSS = +2.8V

Fosc = 615KHZ

Display Patten=Checked pattern

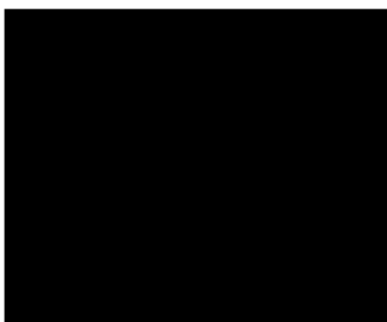

0 gray black pattern



## 7. Timing Characteristics

### 7.1 Display Parallel 16/9/8-bit Interface Timing Characteristics(8080- II system)

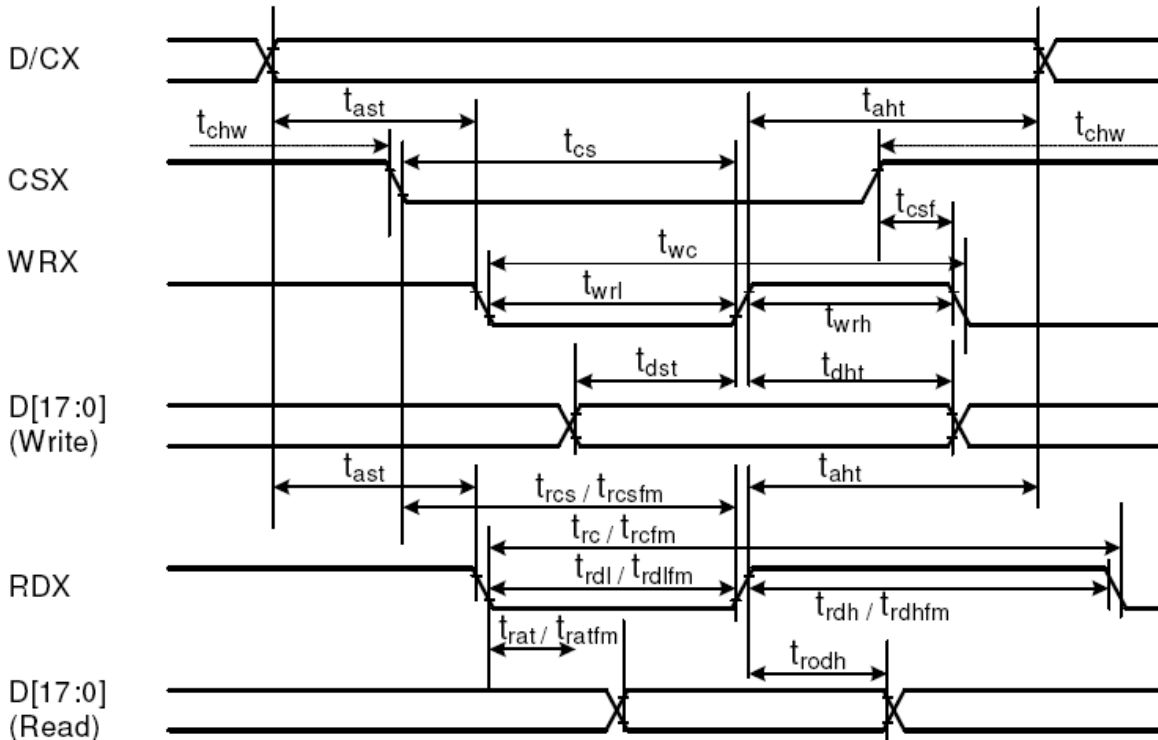

Signal	Symbol	Parameter	min	max	Unit	Description
DCX	tast	Address setup time	0	-	ns	
	taht	Address hold time (Write/Read)	0	-	ns	
CSX	tchw	CSX "H" pulse width	0	-	ns	
	tcs	Chip Select setup time (Write)	15	-	ns	
	trcs	Chip Select setup time (Read ID)	45	-	ns	
	trcsfm	Chip Select setup time (Read FM)	355	-	ns	
	tcsf	Chip Select Wait time (Write/Read)	10	-	ns	
WRX	twc	Write cycle	66	-	ns	
	twrh	Write Control pulse H duration	15	-	ns	
	twrl	Write Control pulse L duration	15	-	ns	
RDX (FM)	trcfm	Read Cycle (FM)	450	-	ns	
	trdhfm	Read Control H duration (FM)	90	-	ns	
	trdlfm	Read Control L duration (FM)	355	-	ns	
RDX (ID)	trc	Read cycle (ID)	160	-	ns	
	trdh	Read Control pulse H duration	90	-	ns	
	trdl	Read Control pulse L duration	45	-	ns	
D[17:0], D[17:10]&D[8:1], D[17:10], D[17:9]	tdst	Write data setup time	10	-	ns	For maximum CL=30pF For minimum CL=8pF
	tdht	Write data hold time	10	-	ns	
	trat	Read access time	-	40	ns	
	tratfm	Read access time	-	340	ns	
	trod	Read output disable time	20	80	ns	

Note:  $T_a = -30$  to  $70$  °C,  $V_{DDI}=1.65V$  to  $3.3V$ ,  $V_{CI}=2.5V$  to  $3.3V$ ,  $V_{SS}=0V$ .

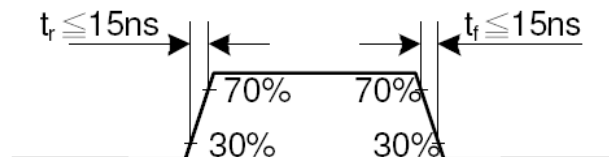

### CSX timings :

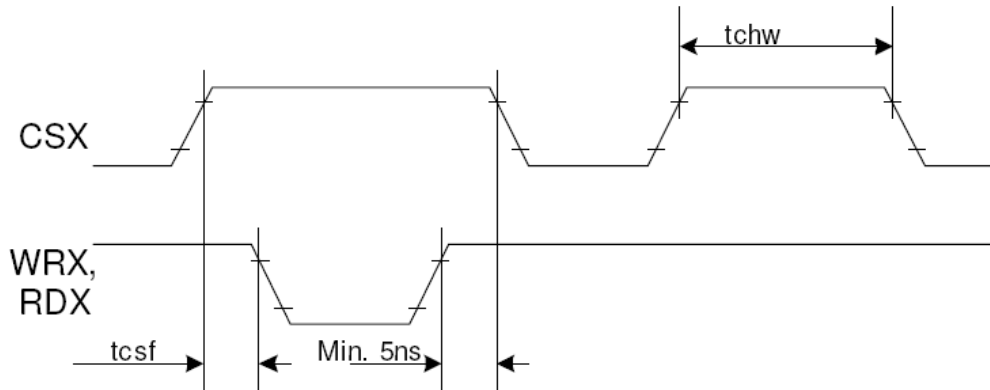

Note: Logic high and low levels are specified as 30% and 70% of VDDI for Input signals.

### Write to read or read to write timings:

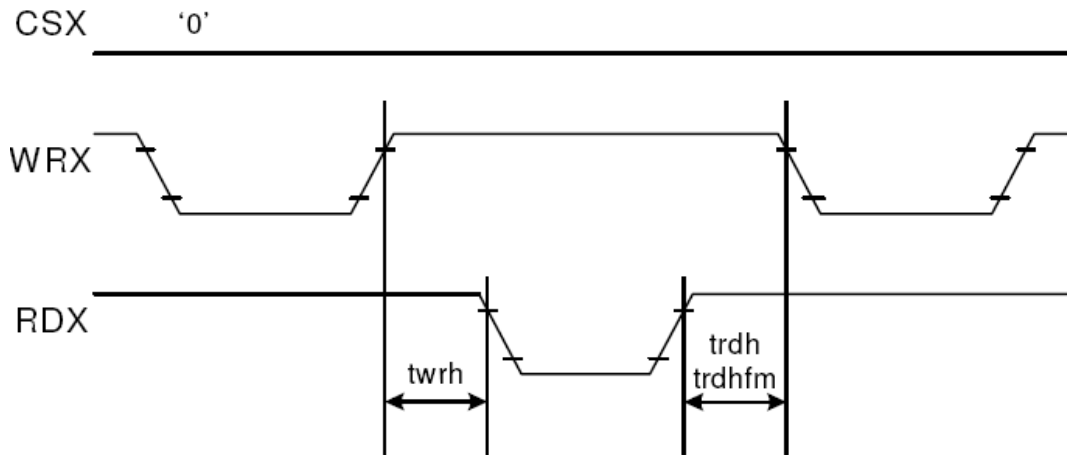

Note: Logic high and low levels are specified as 30% and 70% of VDDI for Input signals.

## 7.2 Display Serial Interface Timing Characteristics (4-line SPI system)

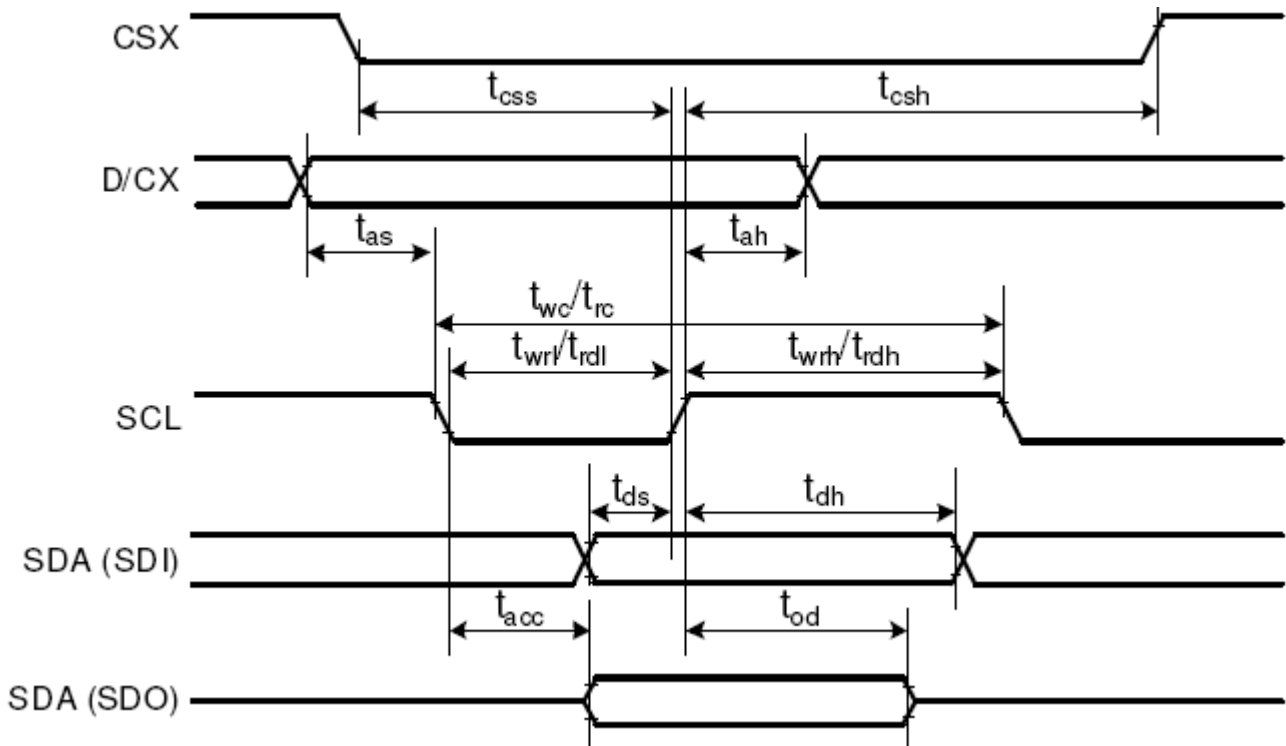

Signal	Symbol	Parameter	min	max	Unit	Description
CSX	$t_{css}$	Chip select time (Write)	40	-	ns	
	$t_{csh}$	Chip select hold time (Read)	40	-	ns	
SCL	$t_{wc}$	Serial clock cycle (Write)	100	-	ns	
	$t_{wrh}$	SCL "H" pulse width (Write)	40	-	ns	
	$t_{wrl}$	SCL "L" pulse width (Write)	40	-	ns	
	$t_{rc}$	Serial clock cycle (Read)	150	-	ns	
	$t_{rdh}$	SCL "H" pulse width (Read)	60	-	ns	
	$t_{rdl}$	SCL "L" pulse width (Read)	60	-	ns	
D/CX	$t_{as}$	D/CX setup time	10	-		
	$t_{ah}$	D/CX hold time (Write / Read)	10	-		
SDA / SDI (Input)	$t_{ds}$	Data setup time (Write)	30	-	ns	
	$t_{dh}$	Data hold time (Write)	30	-	ns	
SDA / SDO (Output)	$t_{acc}$	Access time (Read)	10	-	ns	For maximum $CL=30pF$
	$t_{od}$	Output disable time (Read)	10	50	ns	For minimum $CL=8pF$

Note:  $T_a = 25\text{ }^\circ\text{C}$ ,  $V_{DDI}=1.65\text{V to }3.3\text{V}$ ,  $V_{CI}=2.5\text{V to }3.3\text{V}$ ,  $AGND=V_{SS}=0\text{V}$

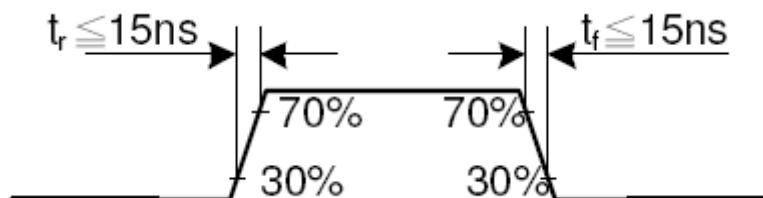

## 7.3 Display Serial Interface Timing Characteristics (3-line SPI system)

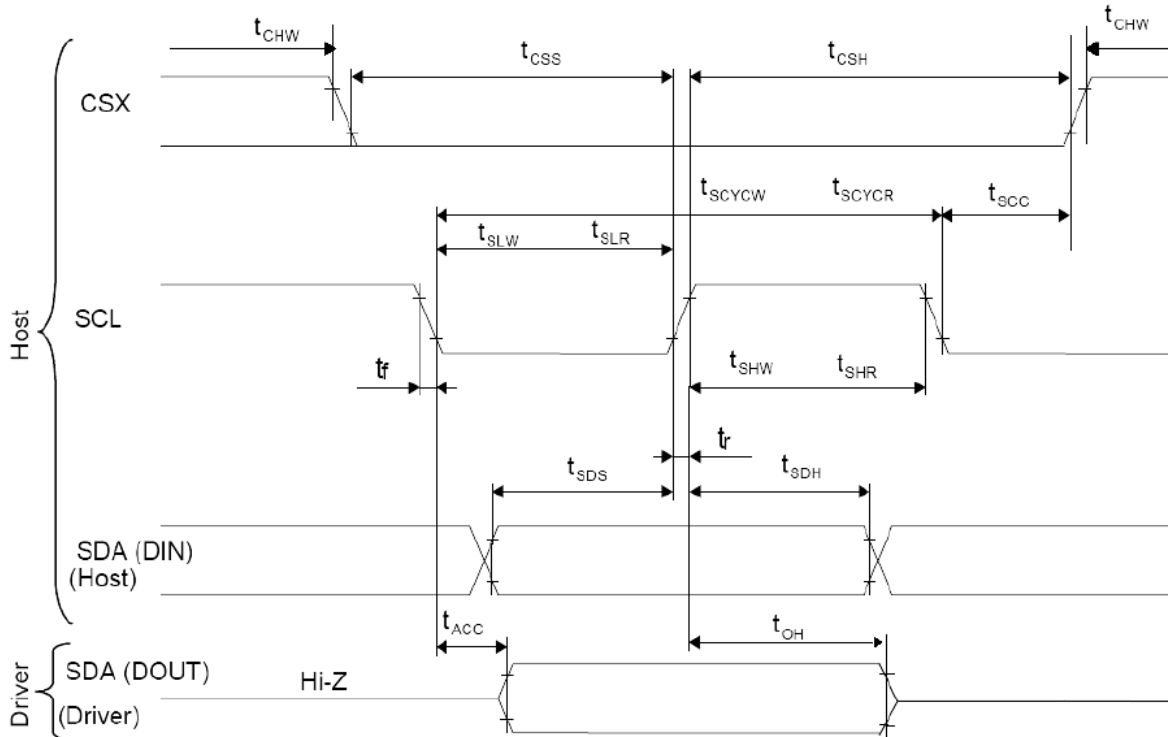

Signal	Symbol	Parameter	min	max	Unit	Description
SCL	tscycw	Serial Clock Cycle (Write)	100	-	ns	
	tshw	SCL "H" Pulse Width (Write)	40	-	ns	
	tslw	SCL "L" Pulse Width (Write)	40	-	ns	
	tscycr	Serial Clock Cycle (Read)	150	-	ns	
	tshr	SCL "H" Pulse Width (Read)	60	-	ns	
	tslr	SCL "L" Pulse Width (Read)	60	-	ns	
SDA / SDI (Input)	tsds	Data setup time (Write)	30	-	ns	
	tsdh	Data hold time (Write)	30	-	ns	
SDA / SDO (Output)	tacc	Access time (Read)	10	-	ns	
	toh	Output disable time (Read)	10	50	ns	
CSX	tsc	SCL-CSX	20	-	ns	
	tchw	CSX "H" Pulse Width	40	-	ns	
	tc	CSX-SCL Time	60	-	ns	
	tch		65	-	ns	

Note:  $T_a = 25\text{ }^\circ\text{C}$ ,  $V_{DDI}=1.65\text{V to }3.3\text{V}$ ,  $V_{CI}=2.5\text{V to }3.3\text{V}$ ,  $AGND=VSS=0\text{V}$

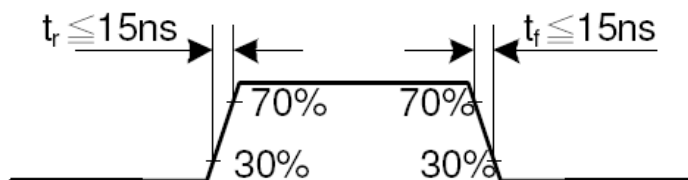

## 8. Backlight Characteristic

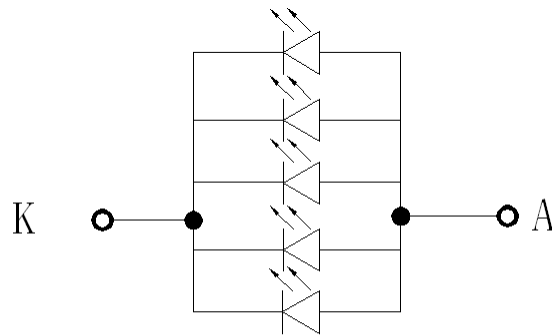

$V_F=3.2V$   $I_F=100mA$

Item	Symbol	MIN	TYP	MAX	UNIT	Test Condition
Supply Voltage	$V_f$	2.9	3.2	3.5	V	$I_f=100mA$
Supply Current	$I_f$	-	100	-	mA	-
Luminous Intensity for LCM+RTP	-	240	280	-	$Cd/m^2$	$I_f=100mA$
Uniformity for LCM	-	80	-	-	%	$I_f=100mA$
Life Time	-	20000	50000	-	Hr	
Backlight Color	White					

## 9. Optical Characteristics

Item	Conditions	Min.	Typ.	Max.	Unit	Note	
Viewing Angle (CR>10)	Horizontal	$\theta_L$	35	45	-	degree	(1),(2),(6)
		$\theta_R$	35	45	-		
	Vertical	$\theta_T$	35	45	-		
		$\theta_B$	10	20	-		
Contrast Ratio	Center	400	500	-	-	(1),(3),(6)	
Response Time	Rising	-	4	8	ms	(1),(4),(6)	
	Falling		12	24	ms	(1),(4),(6)	
CF Color Chromaticity (CIE1931)	Red x	Typ. -0.05	0.626	Typ. +0.05	-	(1), (6)	
	Red y		0.334		-		
	Green x		0.277		-		
	Green y		0.549		-		
	Blue x		0.142		-		
	Blue y		0.122		-		
	White x		0.303		-		
	White y		0.325		-		
Transmittance		-	18.0	-	%	(1),(6)	

Note (1) Measurement Setup: The LCD module should be stabilized at given temp. 25°C for 15 minutes to avoid abrupt temperature change during measuring. In order to stabilize the luminance, the measurement should be executed after lighting backlight for 15 minutes in a windless room.

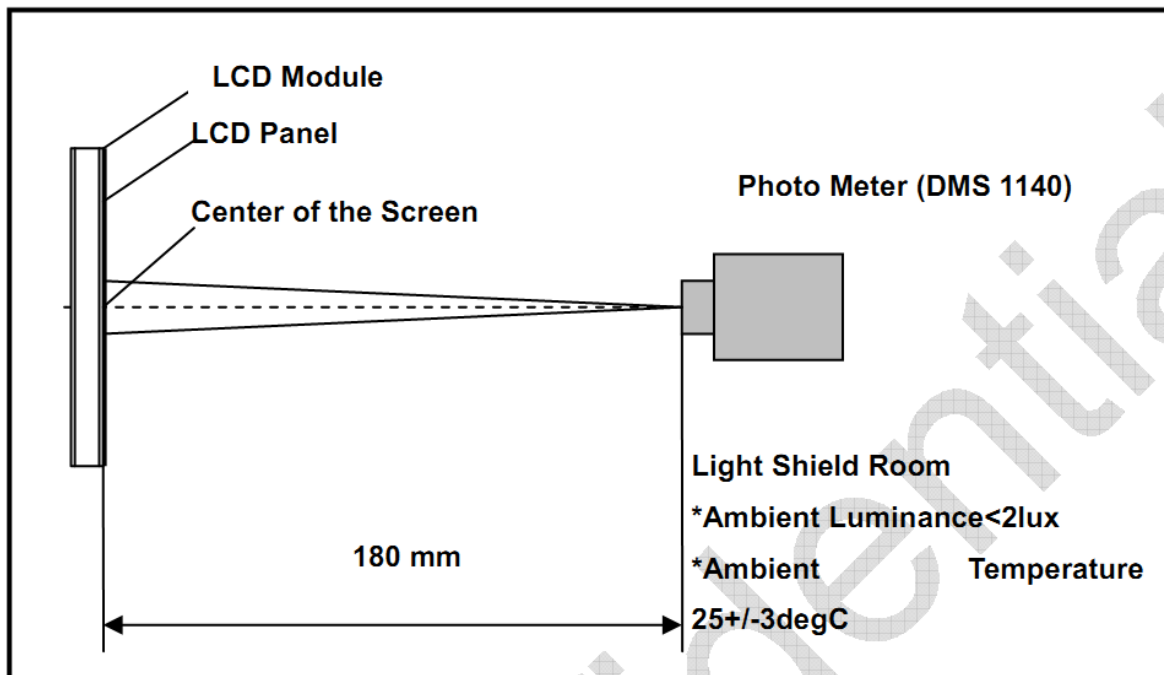

Note (2) Definition of Viewing Angle

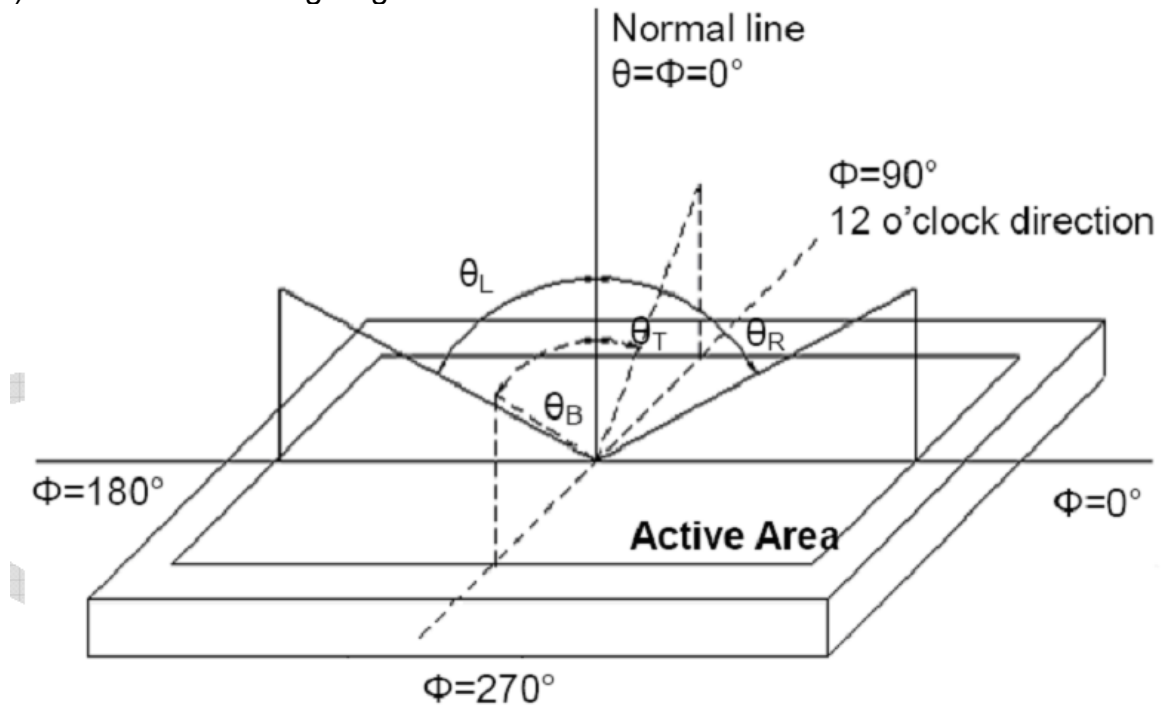

Note (3) Definition Of Contrast Ratio (CR)

The contrast ratio can be calculated by the following expression

$$\text{Contrast Ratio (CR)} = L63 / L0$$

L63: Luminance of gray level 63, L0: Luminance of gray level 0

Note (4) Definition of response time

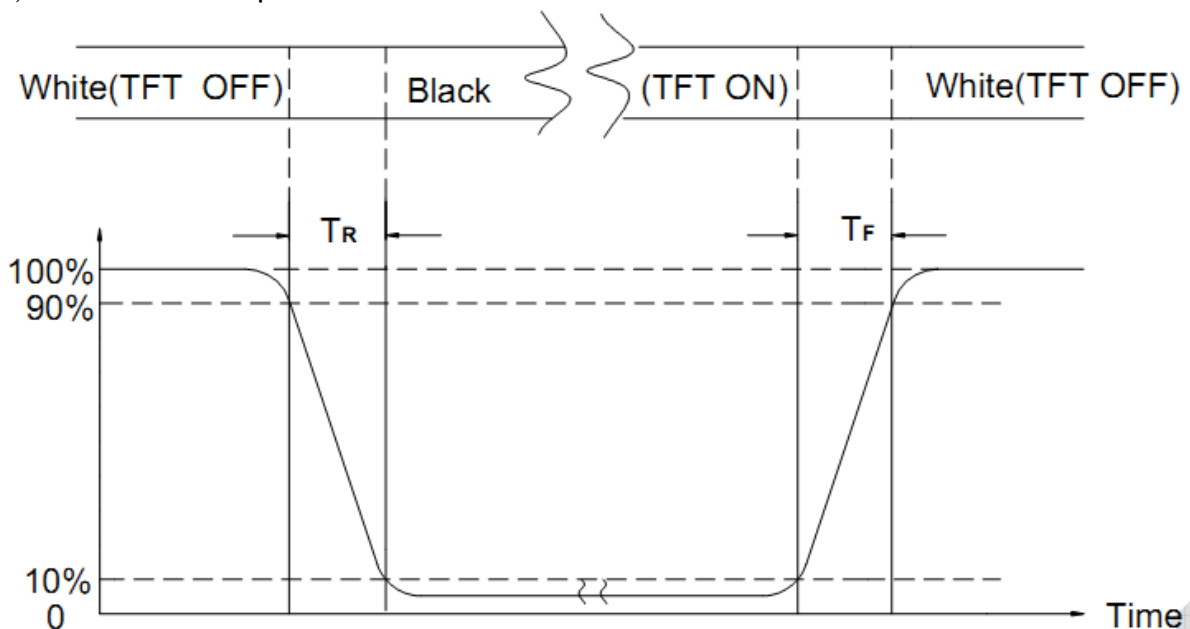

Note (5) Definition of Transmittance (Module is without signal input)

$$\text{Transmittance} = \text{Center Luminance of LCD} / \text{Center Luminance of Back Light} \times 100\%$$

Note (6) Definition of color chromaticity (CIE1931)

Color coordinates measured at the center point of LCD

## 10. Reliability Test Conditions and Methods

NO.	TEST ITEMS	TEST CONDITION	INSPECTION AFTER TEST
①	High Temperature Storage	80°C±2°C×200Hours	Inspection after 2~4hours storage at room temperature, the samples should be free from defects: 1, Air bubble in the LCD. 2, Seal leak. 3, Non-display. 4, Missing segments. 5, Glass crack. 6, Current IDD is twice higher than initial value. 7, The surface shall be free from damage. 8, The electric characteristic requirements shall be satisfied.
②	Low Temperature Storage	-30°C±2°C×200Hours	
③	High Temperature Operating	70°C±2°C×120Hours	
④	Low Temperature Operating	-20°C±2°C×120Hours	
⑤	Temperature Cycle(Storage)	-20°C ↔ 25°C ↔ 70°C (30min) (5min) (30min) 1cycle Total 10cycle	
⑥	Damp Proof Test (Storage)	50°C±5°C×90%RH×120Hours	
⑦	Vibration Test	Frequency:10Hz~55Hz~10Hz Amplitude:1.5M X,Y,Z direction for total 3hours (Packing Condition)	
⑧	Drooping Test	Drop to the ground from 1M height one time every side of carton. (Packing Condition)	
⑨	ESD Test	Voltage:±8KV,R:330Ω,C:150PF,Air Mode,10times	

**REMARK:**

- 1, The Test samples should be applied to only one test item.
- 2, Sample side for each test item is 5~10pcs.
- 3,For Damp Proof Test, Pure water(Resistance > 10MΩ)should be used.
- 4,In case of malfunction defect caused by ESD damage, if it would be recovered to normal state after resetting, it would be judge as a good part.
- 5, EL evaluation should be accepted from reliability test with humidity and temperature: Some defects such as black spot/blemish can happen by natural chemical reaction with humidity and Fluorescence EL has.
- 6, Failure Judgment Criterion: Basic Specification Electrical Characteristic, Mechanical Characteristic, Optical Characteristic.

## 11. Inspection Standard



11.1. QUALITY :

THE QUALITY OF GOODS SUPPLIED TO PURCHASER SHALL COME UP TO THE FOLLOWING STANDARD.

11.1.1. THE METHOD OF PRESERVING GOODS

AFTER DELIVERY OF GOODS FROM AMSON TO PURCHASER. PURCHASER SHALL CONTROL THE LCM AT -10°C TO 40°C ,AND IT MIGHT BE DESIRABLE TO KEEP AT THE NORMAL ROOM TEMPERATURE AND HUMIDITY UNTIL INCOMING INSPECTION OR THROWING INTO PROCESS LINE.

11.1.2. INCOMING INSPECTION

(A) THE METHOD OF INSPECTION

IF PURCHASER MAKE AN INCOMING INSPECTION , A SAMPLING PLAN SHALL BE APPLIED ON THE CONDITION THAT QUALITY OF ONE DELIVERY SHALL BE REGARDED AS ONE LOT.

(B) THE STANDARD OF QUALITY

ISO-2859-1 (SAME AS MIL-STD-105E) , LEVEL II SINGLE PLAN.

CLASS	AQL(%)
CRITICAL	0.4 %
MAJOR	0.65 %
MINOR	1.5 %
TOTAL	1.5 %

EVERY ITEM SHALL BE INSPECTED ACCORDING TO THE CLASS.

(C) MEASURE

IF AS THE RESULT OF ABOVE RECEIVING INSPECTION , A LOT OUT IS DISCOVERED. PURCHASER SHALL BE INFORM SELLER OF IT WITHIN SEVEN DAYS. BUT FIRST SHIPMENT WITHIN FOURTEEN DAYS.

11.1.3. WARRANTY POLICY

AMSON WILL PROVIDE ONE-YEAR WARRANTY FOR THE PRODUCTS ONLY IF UNDER SPECIFICATION OPERATING CONDITIONS. AMSON WILL REPLACE NEW PRODUCTS FOR THESE DEFECT PRODUCTS WHICH UNDER WARRANTY PERIOD AND BELONG TO THE RESPONSIBILITY OF AMSON.

11.2. CHECKING CONDITION

11.2.1. CHECKING DIRECTION SHALL BE IN THE 45 DEGREE AREA TO FACE THE SAMPLE.

11.2.2. CHECKER SHALL SEE OVER 300±25 mm. WITH BARE EYES FAR FROM SAMPLE AND USING 2 PCS. OF 20W FLUORESCENT LAMP.

### 11.3. INSPECTION PLAN :

CLASS	ITEM	JUDGEMENT	CLASS
PACKING & INDICATE	1. OUTSIDE AND INSIDE PACKAGE	"MODEL NO." , "LOT NO." AND "QUANTITY" SHOULD INDICATE ON THE PACKAGE.	Minor
	2. MODEL MIXED AND QUANTITY	OTHER MODEL MIXED.....REJECTED QUANTITY SHORT OR OVER.....REJECTED	Critical
	3. PRODUCT INDICATION	"MODEL NO." SHOULD INDICATE ON THE PRODUCT	Major
ASSEMBLY	4. DIMENSION, LCD GLASS SCRATCH AND SCRIBE DEFECT.	ACCORDING TO SPECIFICATION OR DRAWING.	Major
APPEARANCE	5. VIEWING AREA	POLARIZER EDGE OR LCD'S SEALING LINE IS VISABLE IN THE VIEWING AREA .....REJECTED	Minor
	6. BLEMISH · BLACK SPOT · WHITE SPOT IN THE LCD AND LCD GLASS CRACKS	ACCORDING TO STANDARD OF VISUAL INSPECTION(INSIDE VIEWING AREA)	Minor
	7. BLEMISH · BLACK SPOT WHITE SPOT AND SCRATCH ON THE POLARIZER	ACCORDING TO STANDARD OF VISUAL INSPECTION(INSIDE VIEWING AREA)	Minor
	8. BUBBLE IN POLARIZER	ACCORDING TO STANDARD OF VISUAL INSPECTION(INSIDE VIEWING AREA)	Minor
	9. LCD'S RAINBOW COLOR	STRONG DEVIATION COLOR ( OR NEWTON RING) OF LCD.....REJECTED. OR ACCORDING TO LIMITED SAMPLE ( IF NEEDED, AND INSIDE VIEWING AREA )	Minor
ELECTRICAL	10. ELECTRICAL AND OPTICAL CHARACTERISTICS ( CONTRAST· VOP · CHROMATICITY ... ETC )	ACCORDING TO SPECIFICATION OR DRAWING . ( INSIDE VIEWING AREA )	Critical
	11.MISSING LINE	MISSING DOT · LINE · CHARACTER .....REJECTED	Critical
	12.SHORT CIRCUIT· WRONG PATTERN DISPLAY	NO DISPLAY · WRONG PATTERN DISPLAY · CURRENT CONSUMPTION OUT OF SPECIFICATION..... REJECTED	Critical
	13. DOT DEFECT (FOR COLOR AND TFT)	ACCORDING TO STANDARD OF VISUAL INSPECTION	Minor

### 11.4. STANDARD OF VISUAL INSPECTION

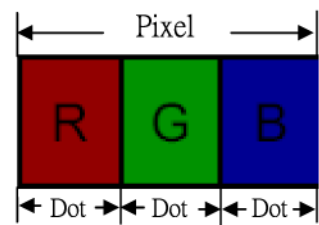
NO.	CLASS	ITEM	JUDGEMENT																				
11.4.1	MINOR	BLACK AND WHITE SPOT FOREIGN MATERIEL DUST IN THE CELL BLEMISH SCRATCH	<p>(A) ROUND TYPE: <span style="float: right;">unit : mm.</span></p> <table border="1" style="width: 100%; border-collapse: collapse;"> <thead> <tr> <th style="width: 60%;">DIAMETER (mm.)</th> <th style="width: 40%;">ACCEPTABLE Q'TY</th> </tr> </thead> <tbody> <tr> <td style="text-align: center;"><math>\Phi \leq 0.1</math></td> <td style="text-align: center;">DISREGARD</td> </tr> <tr> <td style="text-align: center;"><math>0.1 &lt; \Phi \leq 0.25</math></td> <td style="text-align: center;">3 (Distance&gt;5mm)</td> </tr> <tr> <td style="text-align: center;"><math>0.25 &lt; \Phi</math></td> <td style="text-align: center;">0</td> </tr> </tbody> </table> <p style="font-size: small;">NOTE: <math>\Phi = (\text{LENGTH} + \text{WIDTH}) / 2</math></p> <p>(B) LINEAR TYPE: <span style="float: right;">unit : mm.</span></p> <table border="1" style="width: 100%; border-collapse: collapse;"> <thead> <tr> <th style="width: 20%;">LENGTH</th> <th style="width: 30%;">WIDTH</th> <th style="width: 50%;">ACCEPTABLE Q'TY</th> </tr> </thead> <tbody> <tr> <td style="text-align: center;">-----</td> <td style="text-align: center;"><math>W \leq 0.03</math></td> <td style="text-align: center;">DISREGARD</td> </tr> <tr> <td style="text-align: center;"><math>L \leq 5.0</math></td> <td style="text-align: center;"><math>0.03 &lt; W \leq 0.07</math></td> <td style="text-align: center;">3 (Distance&gt;5mm)</td> </tr> <tr> <td style="text-align: center;">-----</td> <td style="text-align: center;"><math>0.07 &lt; W</math></td> <td style="text-align: center;">FOLLOW ROUND TYPE</td> </tr> </tbody> </table>	DIAMETER (mm.)	ACCEPTABLE Q'TY	$\Phi \leq 0.1$	DISREGARD	$0.1 < \Phi \leq 0.25$	3 (Distance>5mm)	$0.25 < \Phi$	0	LENGTH	WIDTH	ACCEPTABLE Q'TY	-----	$W \leq 0.03$	DISREGARD	$L \leq 5.0$	$0.03 < W \leq 0.07$	3 (Distance>5mm)	-----	$0.07 < W$	FOLLOW ROUND TYPE
DIAMETER (mm.)	ACCEPTABLE Q'TY																						
$\Phi \leq 0.1$	DISREGARD																						
$0.1 < \Phi \leq 0.25$	3 (Distance>5mm)																						
$0.25 < \Phi$	0																						
LENGTH	WIDTH	ACCEPTABLE Q'TY																					
-----	$W \leq 0.03$	DISREGARD																					
$L \leq 5.0$	$0.03 < W \leq 0.07$	3 (Distance>5mm)																					
-----	$0.07 < W$	FOLLOW ROUND TYPE																					
11.4.2	MINOR	BUBBLE IN POLARIZER DENT ON POLARIZER	<p style="text-align: right;">unit : mm.</p> <table border="1" style="width: 100%; border-collapse: collapse;"> <thead> <tr> <th style="width: 60%;">DIAMETER</th> <th style="width: 40%;">ACCEPTABLE Q'TY</th> </tr> </thead> <tbody> <tr> <td style="text-align: center;"><math>\Phi \leq 0.2</math></td> <td style="text-align: center;">DISREGARD</td> </tr> <tr> <td style="text-align: center;"><math>0.2 &lt; \Phi \leq 0.5</math></td> <td style="text-align: center;">2 (Distance&gt;5mm)</td> </tr> <tr> <td style="text-align: center;"><math>0.5 &lt; \Phi</math></td> <td style="text-align: center;">0</td> </tr> </tbody> </table>	DIAMETER	ACCEPTABLE Q'TY	$\Phi \leq 0.2$	DISREGARD	$0.2 < \Phi \leq 0.5$	2 (Distance>5mm)	$0.5 < \Phi$	0												
DIAMETER	ACCEPTABLE Q'TY																						
$\Phi \leq 0.2$	DISREGARD																						
$0.2 < \Phi \leq 0.5$	2 (Distance>5mm)																						
$0.5 < \Phi$	0																						
11.4.3	MINOR	Dot Defect	<table border="1" style="width: 100%; border-collapse: collapse;"> <thead> <tr> <th style="width: 50%;">Items</th> <th style="width: 50%;">ACC. Q'TY</th> </tr> </thead> <tbody> <tr> <td>Bright dot</td> <td style="text-align: center;"><math>N \leq 4</math> (Distance&gt;5mm)</td> </tr> <tr> <td>Dark dot</td> <td style="text-align: center;"><math>N \leq 4</math> (Distance&gt;5mm)</td> </tr> </tbody> </table> <p>Pixel Define :</p> <div style="text-align: center;">  </div> <p>Note 1: The definition of dot: The size of a defective dot over 1/2 of whole dot is regarded as one defective dot.</p> <p>Note 2: Bright dot: Dots appear bright and unchanged in size in which LCD panel is displaying under black pattern.</p> <p>Note 3: Dark dot: Dots appear dark and unchanged in size in which LCD panel is displaying under pure red, green, blue pattern.</p>	Items	ACC. Q'TY	Bright dot	$N \leq 4$ (Distance>5mm)	Dark dot	$N \leq 4$ (Distance>5mm)														
Items	ACC. Q'TY																						
Bright dot	$N \leq 4$ (Distance>5mm)																						
Dark dot	$N \leq 4$ (Distance>5mm)																						

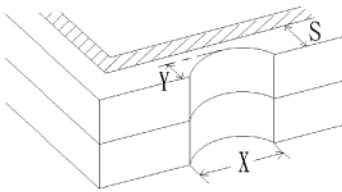
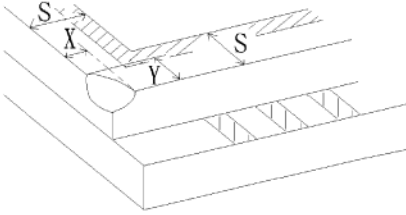
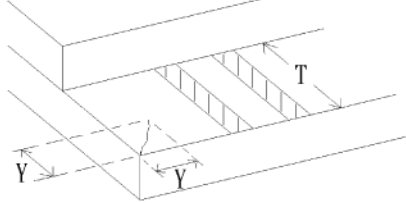
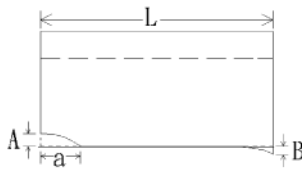
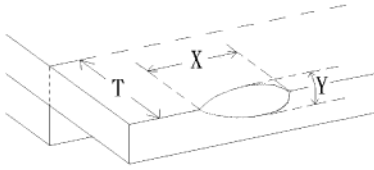
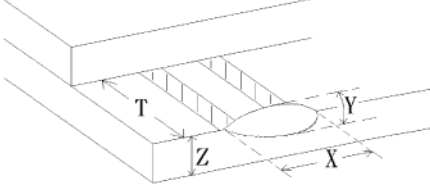
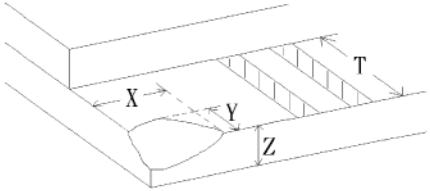
NO.	CLASS	ITEM	JUDGEMENT
11.4.4	MINOR	LCD GLASS CHIPPING	 $Y > S$ Reject
11.4.5	MINOR	LCD GLASS CHIPPING	 $X \text{ or } Y > S$ Reject
11.4.6	MAJOR	LCD GLASS GLASS CRACK	 $Y > (1/2) T$ Reject
11.4.7	MAJOR	LCD GLASS SCRIBE DEFECT	 <ol style="list-style-type: none"> <li><math>a &gt; L/3</math>, <math>A &gt; 1.5\text{mm}</math>. Reject</li> <li>B: ACCORDING TO DIMENSION</li> </ol>
11.4.8	MINOR	LCD GLASS CHIPPING ( ON THE TERMINAL AREA )	 $\Phi = (x+y)/2 > 2.5 \text{ mm}$ Reject
11.4.9	MINOR	LCD GLASS CHIPPING ( ON THE TERMINAL SURFACE )	 $Y > (1/3) T$ Reject
11.4.10	MINOR	LCD GLASS CHIPPING	 $Y > T$ Reject

## 12. Handling Precautions

### 12.1 Mounting method

The LCD panel of AMSON TFT module consists of two thin glass plates with polarizers which easily be damaged. And since the module is so constructed as to be fixed by utilizing fitting holes in the printed circuit board.

Extreme care should be needed when handling the LCD modules.

### 12.2 Caution of LCD handling and cleaning

When cleaning the display surface, Use soft cloth with solvent

[Recommended below] and wipe lightly

- Isopropyl alcohol
- Ethyl alcohol

Do not wipe the display surface with dry or hard materials that will damage the polarizer surface.

Do not use the following solvent:

- Water
- Aromatics

Do not wipe ITO pad area with the dry or hard materials that will damage the ITO patterns

Do not use the following solvent on the pad or prevent it from being contaminated:

- Soldering flux
- Chlorine (Cl) , Sulfur (S)

If goods were sent without being silicon coated on the pad, ITO patterns could be damaged due to the corrosion as time goes on.

If ITO corrosion happens by miss-handling or using some materials such as Chlorine (Cl), Sulfur (S) from customer, Responsibility is on customer.

### 12.3 Caution against static charge

The LCD module uses C-MOS LSI drivers, so we recommend that you:

Connect any unused input terminal to POWER or GROUND, do not input any signals before power is turned on, and ground your body, work/assembly areas, and assembly equipment to protect against static electricity.

### 12.4 packing

- Module employs LCD elements and must be treated as such.
- Avoid intense shock and falls from a height.
- To prevent modules from degradation, do not operate or store them exposed direct to sunshine or high temperature/humidity

### 12.5 Caution for operation

- It is an indispensable condition to drive LCD's within the specified voltage limit since the higher voltage than the limit causes the shorter LCD life.
- An electrochemical reaction due to direct current causes LCD's undesirable deterioration, so that the use of direct current drive should be avoided.
- Response time will be extremely delayed at lower temperature than the operating temperature range and on the other hand at higher temperature LCD's show dark color in them. However those phenomena do not mean malfunction or out of order with LCD's, which will come back in the specified operation temperature.
- If the display area is pushed hard during operation, some font will be abnormally displayed but it resumes normal condition after turning off once.
- Slight dew depositing on terminals is a cause for electro-chemical reaction resulting in terminal open circuit.

Usage under the maximum operating temperature, 50%Rh or less is required.

## 12.6 storing

In the case of storing for a long period of time for instance, for years for the purpose or replacement use, the following ways are recommended.

- Storage in a polyethylene bag with the opening sealed so as not to enter fresh air outside in it. And with no desiccant.
- Placing in a dark place where neither exposure to direct sunlight nor light's keeping the storage temperature range.
- Storing with no touch on polarizer surface by the anything else.  
[It is recommended to store them as they have been contained in the inner container at the time of delivery from us

## 12.7 Safety

- It is recommendable to crash damaged or unnecessary LCD's into pieces and wash off liquid crystal by either of solvents such as acetone and ethanol, which should be burned up later.
- When any liquid leaked out of a damaged glass cell comes in contact with your hands, please wash it off well with soap and water

## 13. Precaution for Use

### 13.1

A limit sample should be provided by the both parties on an occasion when the both parties agreed its necessity. Judgment by a limit sample shall take effect after the limit sample has been established and confirmed by the both parties.

### 13.2

On the following occasions, the handing of problem should be decided through discussion and agreement between responsible of the both parties.

- When a question is arisen in this specification
- When a new problem is arisen which is not specified in this specifications
- When an inspection specifications change or operating condition change in customer is reported to AMSON TFT , and some problem is arisen in this specification due to the change
- When a new problem is arisen at the customer's operating set for sample evaluation in the customer site.

## 14. Packing Method

TBD