

# Specification for Approval

Customer: \_\_\_\_\_

Model Name: \_\_\_\_\_

Supplier Approval			Customer approval
R&D Designed	R&D Approved	QC Approved	
<i>Peter</i>	<i>Peng Jun</i>		



# Revision Record

REV NO.	REV DATE	CONTENTS	Note
A	2019-01-16	NEW ISSUE	

## Table of Contents

List	Description	Page No.
	Cover	1
	Revision Record	2
	Table of Contents	3
1	Scope	4
2	General Information	4
3	External Dimensions	5
4	Interface Description	6
5	Electrical specification	8
6	Absolute Maximum Ratings	8
7	Timing Characteristics	9
8	Backlight Characteristics	14
9	Optical Characteristics	15
10	Reliability Test Conditions and Methods	17
11	Inspection Standard	18
12	Handling Precautions	23
13	Precaution for Use	24
14	Packing Method	24

## 1. Scope

This specification defines general provisions as well as inspection standards for TFT module supplied by AMSON electronics.

If the event of unforeseen problem or unspecified items may occur, naturally shall negotiate and agree to solution.

## 2. General Information

ITEM	STANDARD VALUES	UNITS
LCD type	7.0" TFT	--
Dot arrangement	1024×3 (RGB)×600	dots
Color filter array	RGB vertical stripe	--
Display mode	Normally BLACK IPS	--
Viewing Direction	ALL	--
Module size	164.90(W)×100.00(H)×2.8(T)	mm
Active area	154.21(W)×85.92(H)	mm
Dot pitch	0.1506(W)×0.1432(H)	mm
Interface	LVDS	--
Operating temperature	-20 ~ +70	°C
Storage temperature	-30 ~ +80	°C
Module Weight	--	g



## 4. Interface Description

No.	Symbol	I/O	Function
1	VCOM	P	Common voltage
2,3	VDD	P	Digital power
4	NC	-	Not connect
5	RESET	I	Global reset pin. Active low to enter reset state. Suggest to connecting with an RC reset circuit for stability. Normally pull high. (R=100K <sub>Ω</sub> , C=1μF)
6	STBYB	I	Standby mode, normally pull high STBYB="1", normal operation STBYB="0", timing control, source driver will turn off, all output
7	GND	P	Ground
8	RXIN0-	I	Negative LVDS differential data inputs
9	RXIN0+	I	Positive LVDS differential data inputs
10	GND	P	Ground
11	RXIN1-	I	Negative LVDS differential data inputs
12	RXIN1+	I	Positive LVDS differential data inputs
13	GND	P	Ground
14	RXIN2-	I	Negative LVDS differential data inputs
15	RXIN2+	I	Positive LVDS differential data inputs
16	GND	P	Ground
17	RXCLK-	I	Negative LVDS differential clock inputs
18	RXCLK+	I	Positive LVDS differential clock inputs
19	GND	P	Ground
20	RXIN3-	I	Negative LVDS differential data inputs
21	RXIN3+	I	Positive LVDS differential data inputs
22	GND	P	Ground
23,24	NC	-	Not connect
25	GND	P	Ground
26,27	NC	-	Not connect
28	SELB	I	6bit/8bit mode select H : 6bit / L : 8bit
29	AVDD	P	Power for Analog Circuit
30	GND	P	Ground

31,32	LED K	P	LED backlight (Cathode).
33	L/R	I	Horizontal inversion
34	U/D	I	Vertical inversion
35	VGL	P	Negative power for TFT
36	GND	P	Ground
37	GND	P	Ground
38	VGH	P	Positive power for TFT
39,40	LED A	P	LED backlight (Anode).

I : input , O : output , P : Power

**【Note】**

\*1) : When L/R="0" , set right to left scan direction

When L/R="1" , set left to right scan direction

When U/D="0" , set top to bottom scan direction

When U/D="1" , set bottom to top scan direction

## 5. Electrical specification

Item	Symbol	Min.	Typ.	Max.	Unit	Remark
Input signal Voltage	VCOM	3.0	3.6	4.0	V	-
Logic Supply Voltage	VDD	2.3	3.3	3.6	V	-
Analog Supply Voltage	AVDD	8	9.7	13.5	V	
Low Supply Voltage	VGL	-7.1	-6.8	-6.5	V	
High Supply Voltage	VGH	16	18	20.3	V	
Output High Voltage	VIH	0.7XVDD	-	VDD	V	
Output Low Voltage	VIL	0	-	0.3xVDD	V	-

Note 1: Please adjust VCOM to make the flicker level be minimum. Typ VCOM 电压值

只做参考, 具体以实际效果为准 (根据FLICKER 状态可调整)

Note 2: The gate IC is the EK73215BCGA, The source IC is theEK79

## 6. Absolute Maximum Ratings

Item	Symbol	Min.	Max.	Unit
Logic Supply Voltage	VDD	-0.5	5	V
Analog Supply Voltage	AVDD	-0.5	15	V
High Supply Voltage	VGH	-0.3	40	V
Low Supply Voltage	VGL	-20	0.3	V
Operating Temperature	TOP	-20	70	°C
Storage Temperature	TST	-30	80	°C



## 7. Timing Characteristics

### 7.1 POWER ON/OFF SEQUENCE

To prevent the device damage from latch up, the power on/off sequence shown below must be followed.

Power on: VDD, GND \_ AVDD, AGND \_ V1 to V14

Power off: V1 to V14 \_ AVDD, AGND\_ VDD, GND

#### Power on/off control

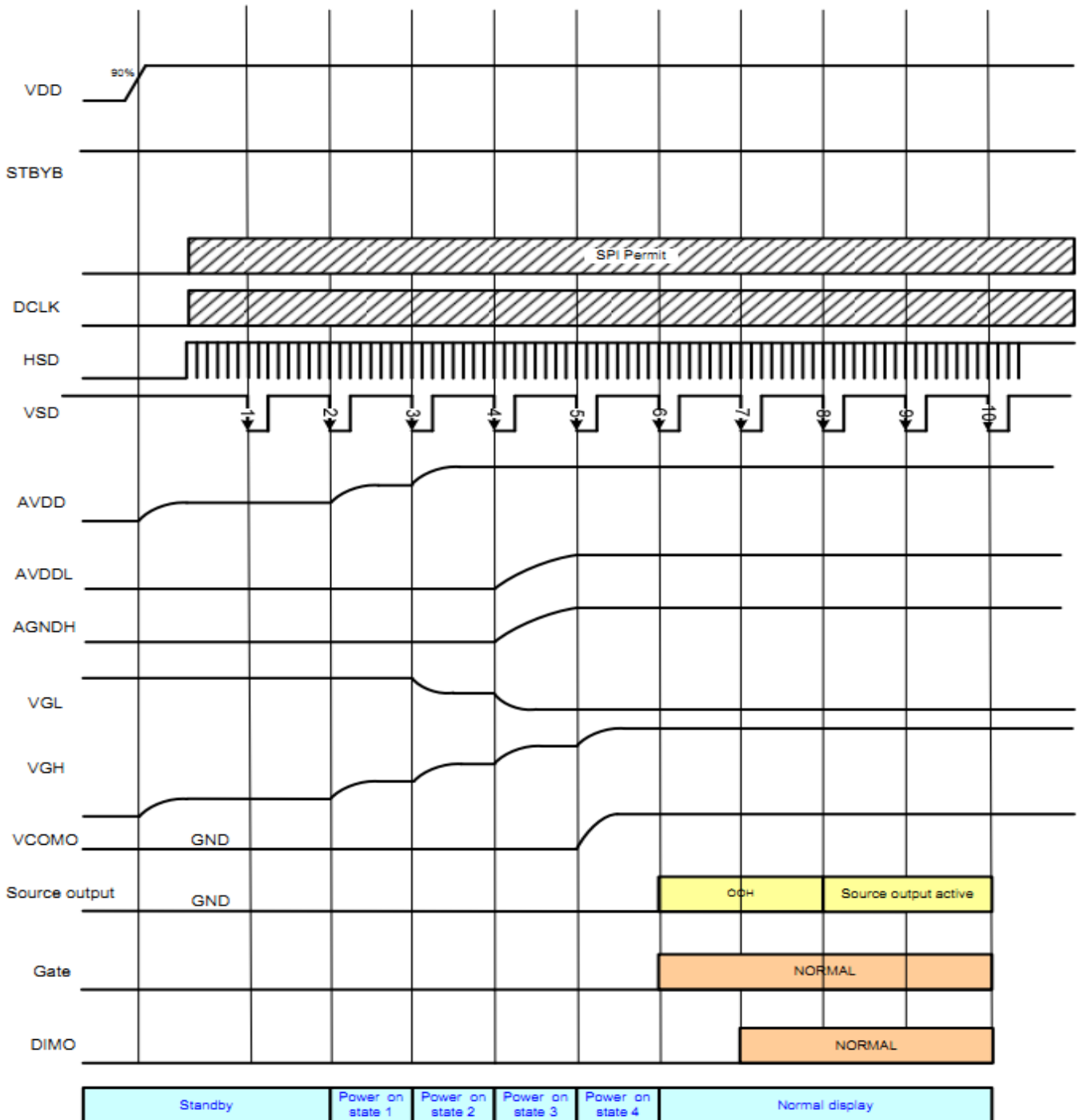

Power on timing sequence

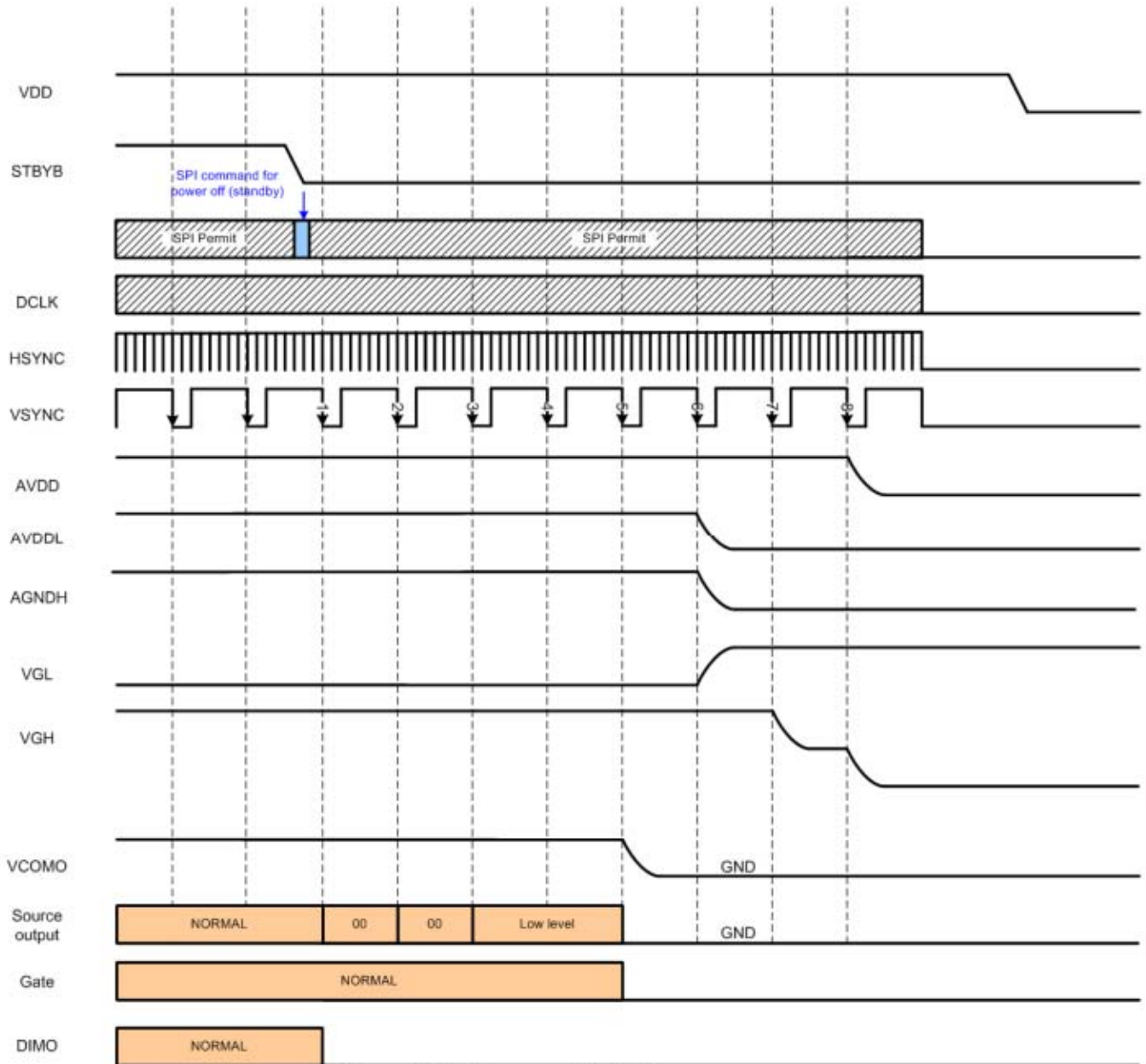

**Power off timing sequence**

## 7.2 INPUT SIGNAL TIMING

### 7.2.1 DC electrical characteristics

#### LVDS mode DC electrical characteristics

Parameter	Symbol	Spec.			Unit	Condition
		Min.	Typ.	Max.		
Differential input high Threshold voltage	$R_{XVTH}$	-	-	+0.1	V	$R_{XVCM}=1.2V$
Differential input low threshold voltage	$R_{XVTL}$	-0.1	-	-	V	
Input voltage range (singled-end)	$R_{XVIN}$	0	-	$VDD-1.2+ V_{ID} /2$	V	-
Differential input common Mode voltage	$R_{XVCM}$	$ V_{ID} /2$	-	$VDD-1.2$	V	-
Differential input voltage	$ V_{ID} $	0.2	-	0.6	V	-
Differential input leakage Current	$R_{V_{XIIz}}$	-10	-	+10	$\mu A$	-
LVDS Digital Operating Current	$I_{ddlvds}$	-	15	30	mA	Fclk=65MHz, VDD=3.3V
LVDS Digital Stand-by Current	$I_{stlvds}$	-	10	50	$\mu A$	Clock & all Functions are stopped

#### Single-end signals

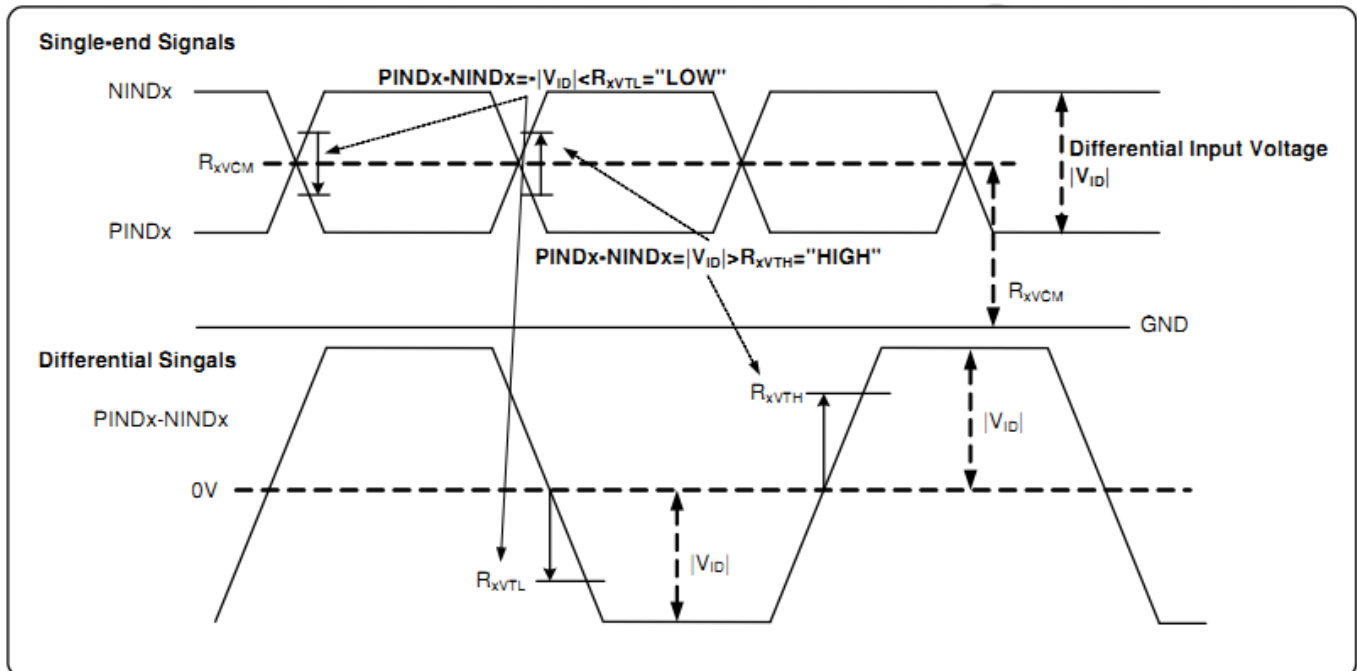

## 7.2.2AC ELECTRICAL CHARACTERISTICS

### LVDS mode AC electrical characteristics

Parameter	Symbol	Spec.			Unit	Condition
		Min.	Typ.	Max.		
Clock frequency	$R_{XFCLK}$	20	-	71	MHz	-
Input data skew margin	$T_{RSKM}$	500	-	-	pS	$ V_{ID} =400mV$ $R_{XVCM}=1.2V$ $R_{XFCLK}=71MHz$
Clock high time	$T_{LVCH}$	-	$4/(7 * R_{XFCLK})$	-	ns	-
Clock low time	$T_{LVCL}$	-	$3/(7 * R_{XFCLK})$	-	ns	-
PLL wake-up time	$T_{enPLL}$	-	-	150	$\mu s$	-

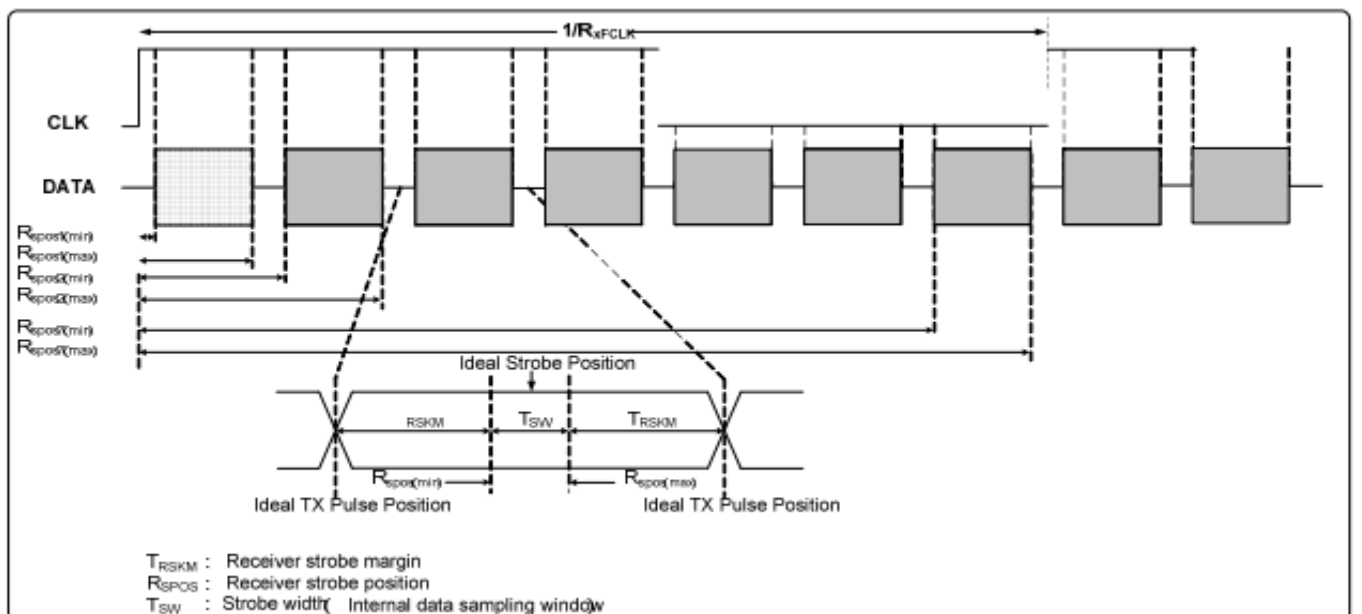
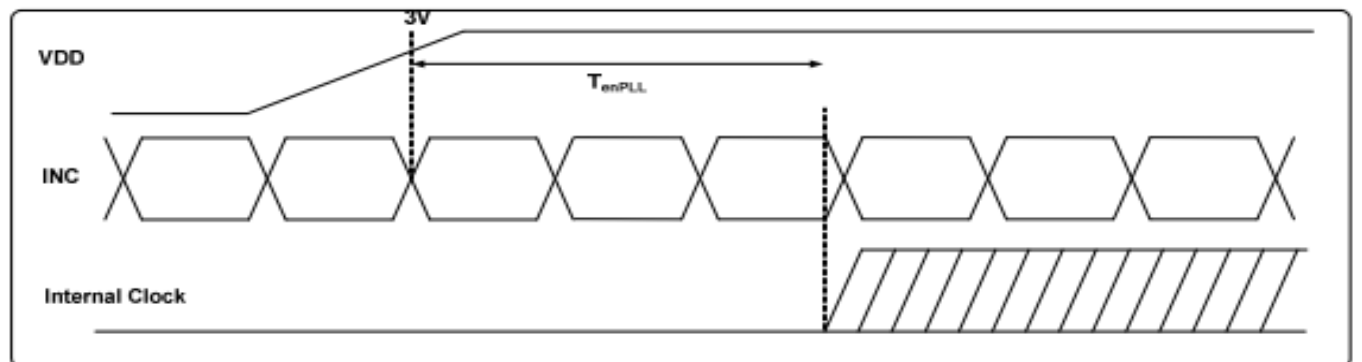
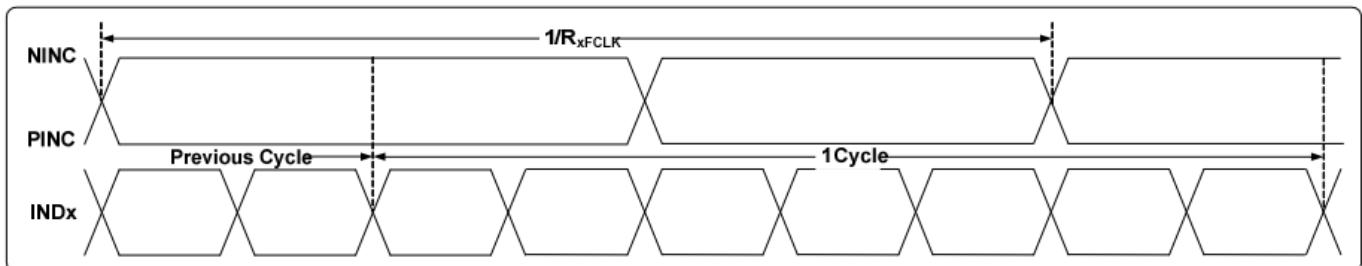

### LVDS mode data input format

### 7.2.3 LVDS mode data input format

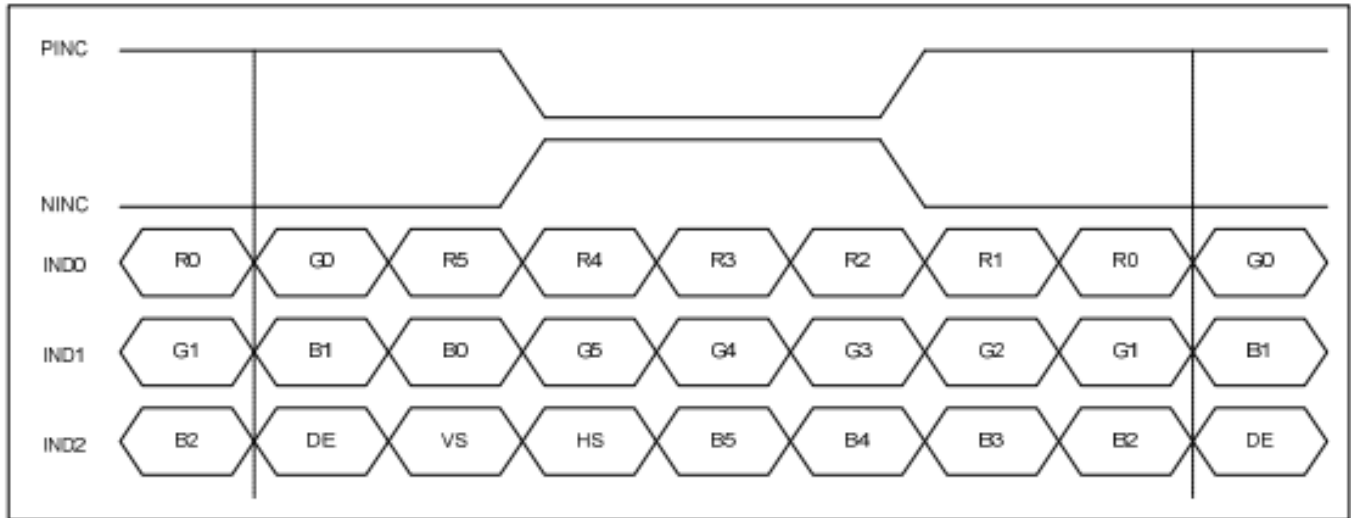

**6-bit LVDS input**

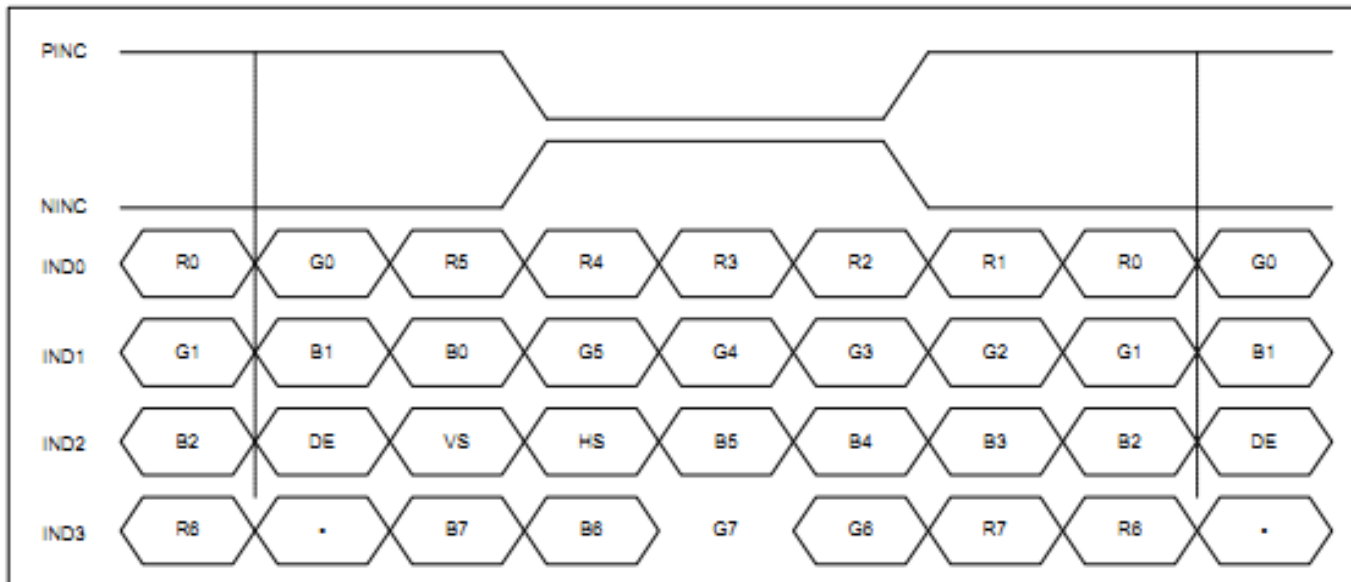

**8-bit LVDS input**

## 8. Backlight Characteristic

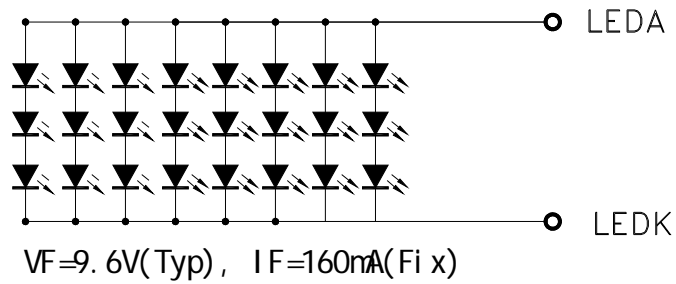

Item	Symbol	MIN	TYP	MAX	UNIT	Test Condition
Supply Voltage	Vf	8.7	9.6	10.5	V	If=160mA
Supply Current	If	-	160	-	mA	-
Luminous Intensity for LCM	-	400	450	-	cd/m <sup>2</sup>	If=160mA
Uniformity for LCM	-	80	-	-	%	If=160mA
Life Time	-	-	50000	-	Hr	If=160mA
Backlight Color	White					

## 9. Optical Characteristics

Item	Conditions	Min.	Typ.	Max.	Unit	Note	
Viewing Angle (CR>10)	Horizontal	$\theta_L$	-	85	-	degree	(1),(2),(6)
		$\theta_R$	-	85	-		
	Vertical	$\theta_T$	-	85	-		
		$\theta_B$	-	85	-		
Contrast Ratio	Center	600	800	-	-	(1),(3),(6)	
Response Time	Rising	-	25	40	ms	(1),(4),(6)	
	Falling						
CF Color Chromaticity (CIE1931)	Red x	Typ. -0.05	TBD	Typ. +0.05	-	(1), (6)	
	Red y		TBD		-		
	Green x		TBD		-		
	Green y		TBD		-		
	Blue x		TBD		-		
	Blue y		TBD		-		
	White x		TBD		-		
	White y		TBD		-		

Note (1) Measurement Setup: The LCD module should be stabilized at given temp. 25°C for 15 minutes to avoid abrupt temperature change during measuring. In order to stabilize the luminance, the measurement should be executed after lighting backlight for 15 minutes in a windless room.

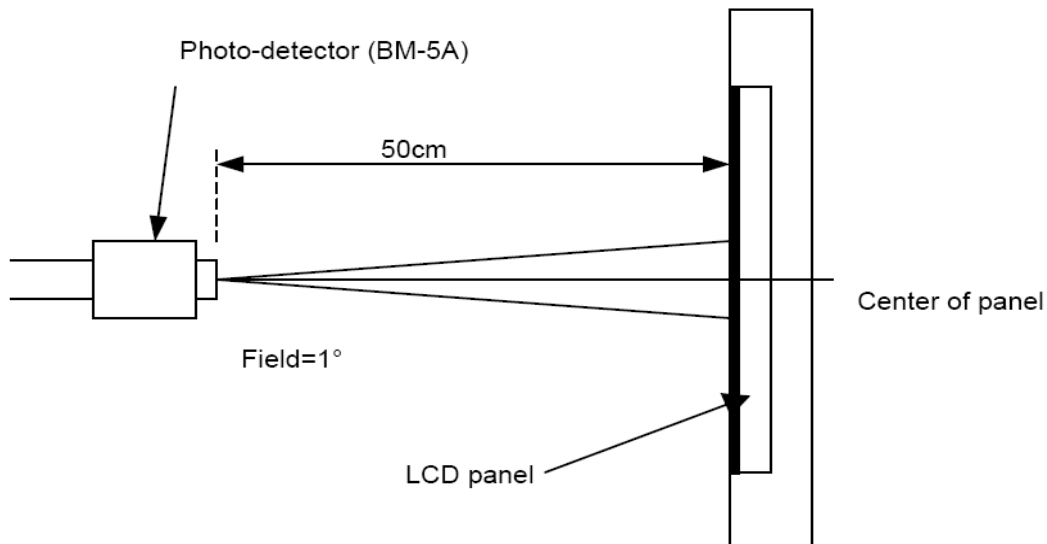

Note (2) Definition of Viewing Angle

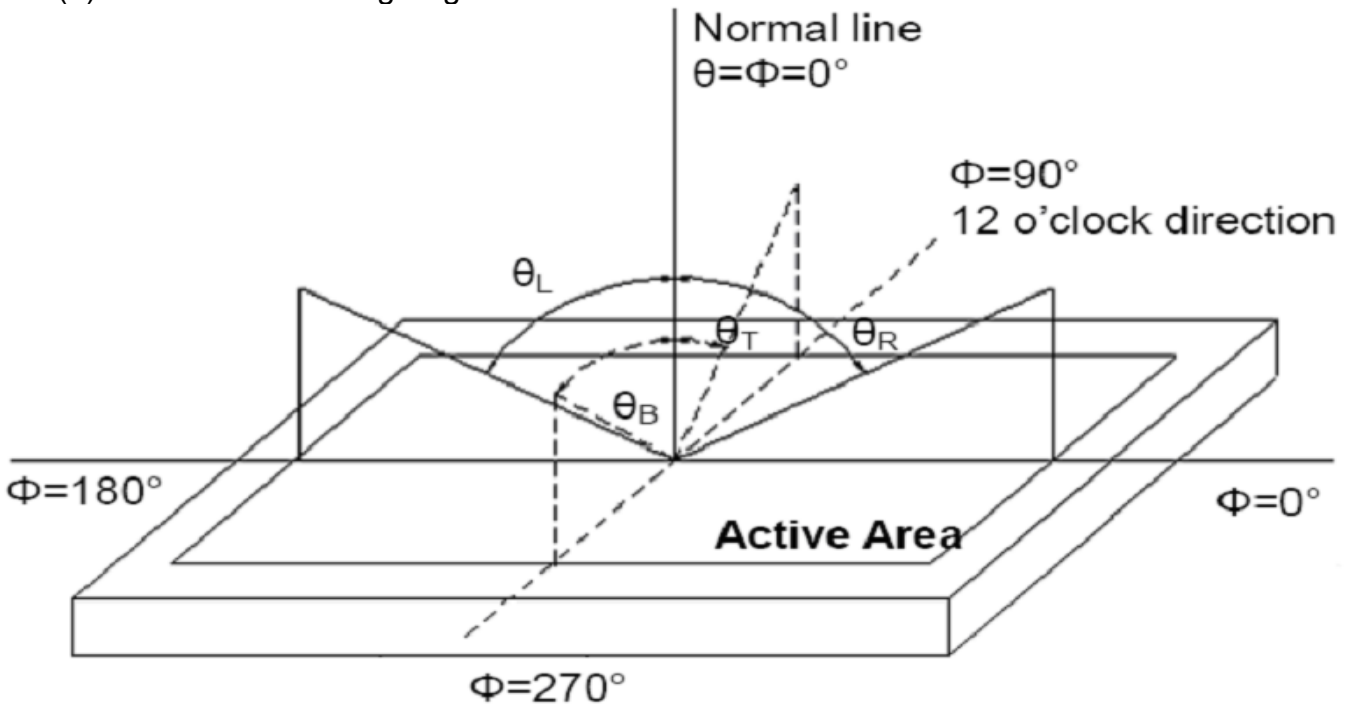

Note (3) Definition of Contrast Ratio (CR)

The contrast ratio can be calculated by the following expression

$$\text{Contrast Ratio (CR)} = L_{63} / L_0$$

L63: Luminance of gray level 63, L0: Luminance of gray level 0

Note (4) Definition of response time

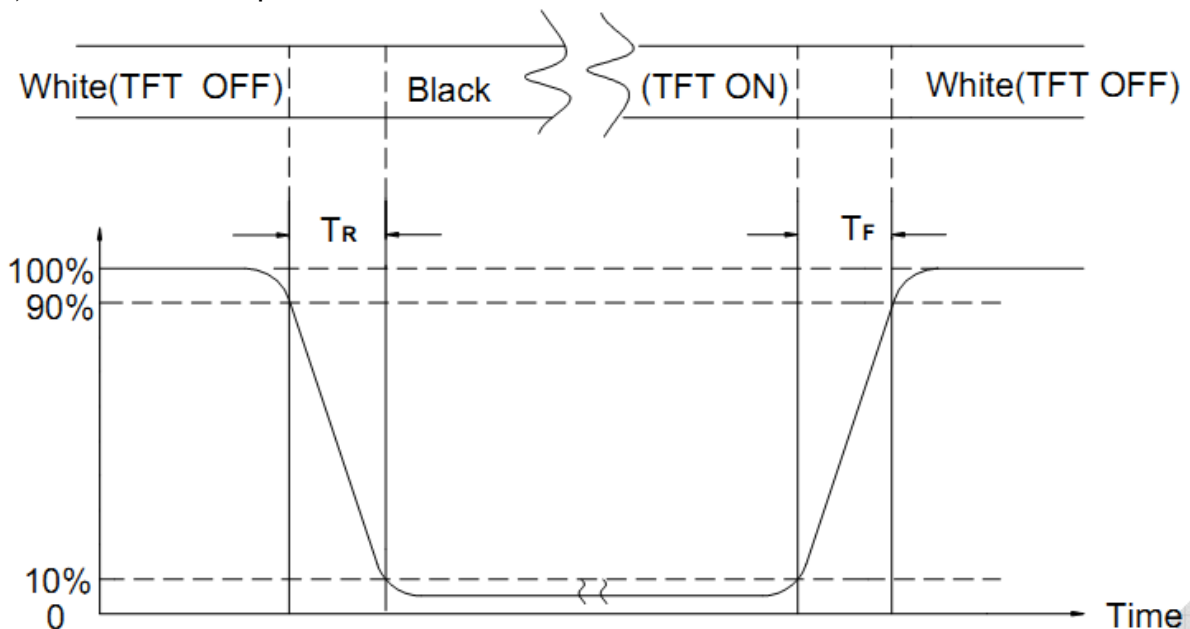

Note (5) Definition of Transmittance (Module is without signal input)

$$\text{Transmittance} = \text{Center Luminance of LCD} / \text{Center Luminance of Back Light} \times 100\%$$

Note (6) Definition of color chromaticity (CIE1931)

Color coordinates measured at the center point of LCD



## 10. Reliability Test Conditions and Methods

NO.	TEST ITEMS	TEST CONDITION											
①	High Temperature Storage	Keep in 80°C ±5°C 96 hrs Surrounding temperature, then storage at normal condition 4hrs.											
②	Low Temperature Storage	Keep in -30°C ±5°C 96 hrs Surrounding temperature, then storage at normal condition 4hrs.											
③	High Temperature / High Humidity Storage Test	Keep in 50 °C / 90% R.H duration for 96 hrs Surrounding temperature, then storage at normal condition 4hrs. (Excluding the polarizer)											
④	Temperature Cycling Storage Test	$  \begin{array}{ccccccc}  & -20^{\circ}\text{C} & \rightarrow & +25^{\circ}\text{C} & \rightarrow & 70^{\circ}\text{C} & \rightarrow & +25^{\circ}\text{C} \\  & (30\text{mins}) & & (5\text{mins}) & & (30\text{mins}) & & (5\text{mins}) \\  & \leftarrow & & & & & & \rightarrow \\  & & & & & \text{10 Cycle} & &   \end{array}  $ Surrounding temperature, then storage at normal condition 4hrs.											
⑤	ESD Test	Air Discharge: Apply 2 KV with 5 times Discharge for each polarity +/-	Contact Discharge: Apply 250 V with 5 times discharge for each polarity +/-										
		1. Temperature ambience : 15°C ~ 35°C 2. Humidity relative : 30% ~ 60% 3. Energy Storage Capacitance( Cs + Cd ) : 150pF±10% 4. Discharge Resistance(Rd) : 330Ω±10% 5. Discharge, mode of operation : Single Discharge (time between successive discharges at least 1 sec) (Tolerance if the output voltage indication : ±5%)											
⑥	Vibration Test (Packaged)	1. Sine wave 10~55 Hz frequency (1 min/sweep) 2. The amplitude of vibration :1.5 mm 3. Each direction (X、Y、Z) duration for 2 Hrs											
⑦	Drop Test (Packaged)	<table border="1"> <thead> <tr> <th>Packing Weight (Kg)</th> <th>Drop Height (cm)</th> </tr> </thead> <tbody> <tr> <td>0 ~ 45.4</td> <td>122</td> </tr> <tr> <td>45.4 ~ 90.8</td> <td>76</td> </tr> <tr> <td>90.8 ~ 454</td> <td>61</td> </tr> <tr> <td>Over 454</td> <td>46</td> </tr> </tbody> </table>		Packing Weight (Kg)	Drop Height (cm)	0 ~ 45.4	122	45.4 ~ 90.8	76	90.8 ~ 454	61	Over 454	46
		Packing Weight (Kg)	Drop Height (cm)										
0 ~ 45.4	122												
45.4 ~ 90.8	76												
90.8 ~ 454	61												
Over 454	46												
		Drop Direction : ※1 corner / 3 edges / 6 sides each 1time											

## 11. Inspection Standard

### 11.1. QUALITY :

THE QUALITY OF GOODS SUPPLIED TO PURCHASER SHALL COME UP TO THE FOLLOWING STANDARD.

#### 11.1.1. INSPECTION TOOLS AND INSTRUMENTS

Vernier calipers, film scales, multimeter, magnifying eyepiece, ND5%, luminance meter and so on.

#### 11.1.2. THE METHOD OF PRESERVING GOODS

AFTER DELIVERY OF GOODS FROM AMSON TO PURCHASER. PURCHASER SHALL CONTROL THE LCM AT -10 TO 40 ,AND IT MIGHT BE DESIRABLE TO KEEP AT THE NORMAL ROOM TEMPERATURE AND HUMIDITY UNTIL INCOMING INSPECTION OR THROWING INTO PROCESS LINE.

#### 11.1.3. INCOMING INSPECTION

(A) THE METHOD OF INSPECTION

IF PURCHASER MAKE AN INCOMING INSPECTION , A SAMPLING PLAN SHALL BE APPLIED ON THE CONDITION THAT QUALITY OF ONE DELIVERY SHALL BE REGARDED AS ONE LOT.

(B) THE STANDARD OF QUALITY

ISO-2859-1 (SAME AS MIL-STD-105E ) ,LEVEL:II

CLASS	AQL(%)
CRITICAL	0.4 %
MAJOR	0.65 %
MINOR	1.5 %

EVERY ITEM SHALL BE INSPECTED ACCORDING TO THE CLASS.

(C) MEASURE

IF AS THE RESULT OF ABOVE RECEIVING INSPECTION , A LOT OUT IS DISCOVERED. PURCHASER SHALL BE INFORM SELLER OF IT WITHIN SEVEN DAYS. BUT FIRST SHIPMENT WITHIN FOURTEEN DAYS.

#### 11.1.4. WARRANTY POLICY

AMSON WILL PROVIDE ONE-YEAR WARRANTY FOR THE PRODUCTS ONLY IF UNDER SPECIFICATION OPERATING CONDITIONS. AMSON WILL REPLACE NEW PRODUCTS FOR THESE DEFECT PRODUCTS WHICH UNDER WARRANTY PERIOD AND BELONG TO THE RESPONSIBILITY OF AMSON.

## 11.2. CHECKING CONDITION

11.2.1.CHECKING DIRECTION SHALL BE IN THE 45 DEGREE AREA TO FACE THE SAMPLE.

11.2.2.CHECKER SHALL SEE OVER 300±25 mm. WITH BARE EYES FAR FROM SAMPLE

11.2.3.Ambient Illumination:

0 ~30 Lux for functional inspection

500 ~ 1200 Lux for external appearance inspection.

11.2.4. TEST AREA:

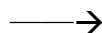

11.2.5. Inspection should be carried out with rope electrostatic ring and static finger cover (both hands except small fingers must be worn)

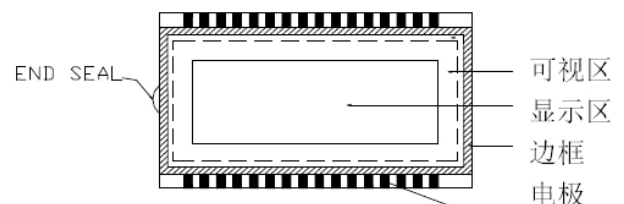

11.2.6. The inspector may make a visual inspection or a comparative examination with a film

ruler and a magnifying eyepiece. Individual defects shall be determined according to the limited samples.

**11.2.7.** Functional testing uses electrical testing fixtures or test fixtures required by customers.

**11.2.8.** the ion fan should be used when testing.

### **11.2.9. the principle of judgment**

11.3.1 If the defect outside the visual area does not affect the assembly and display, it will be judged as a good product.

11.3.2 Poor definition

Pixel:

A combination of three sub-pixels  
(Red + Green + Blue).

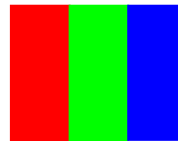

**Dot:**

Any of the sub-pixels  
(Red or Green or Blue).



#### **Bright and dark dots:**

A point pixel (sub-pixel: R, G, B pixels) is lit or turned off during the display function test.

#### **Highlights:**

Usually considered to be shown on a black screen.

#### **Dark spots:**

They are generally considered to be shown on R, G, B solid colors or white images.

#### **Neighborhood:**

Two or three adjacent point pixels (dot: sub-pixel) connected together (R, G or G, B or B, R or RGB).

11.3. INSPECTION PLAN :

CLASS	ITEM	JUDGEMENT	CLASS
PACKING & INDICATE	1. OUTSIDE AND INSIDE PACKAGE	"MODEL NO." , "LOT NO." AND "QUANTITY" SHOULD INDICATE ON THE PACKAGE.	Minor
	2. MODEL MIXED AND QUANTITY	OTHER MODEL MIXED.....REJECTED QUANTITY SHORT OR OVER.....REJECTED	Critical
	3. PRODUCT INDICATION	"MODEL NO." SHOULD INDICATE ON THE PRODUCT	Major
ASSEMBLY	4. DIMENSION, LCD GLASS SCRATCH AND SCRIBE DEFECT.	ACCORDING TO SPECIFICATION OR DRAWING.	Major
APPEARANCE	5. VIEWING AREA	POLARIZER EDGE OR LCD'S SEALING LINE IS VISABLE IN THE VIEWING AREA .....REJECTED	Minor
	6. BLEMISH · BLACK SPOT · WHITE SPOT IN THE LCD AND LCD GLASS CRACKS	ACCORDING TO STANDARD OF VISUAL INSPECTION(INSIDE VIEWING AREA)	Minor
	7. BLEMISH · BLACK SPOT WHITE SPOT AND SCRATCH ON THE POLARIZER	ACCORDING TO STANDARD OF VISUAL INSPECTION(INSIDE VIEWING AREA)	Minor
	8. BUBBLE IN POLARIZER	ACCORDING TO STANDARD OF VISUAL INSPECTION(INSIDE VIEWING AREA)	Minor
	9. LCD'S RAINBOW COLOR	STRONG DEVIATION COLOR ( OR NEWTON RING) OF LCD.....REJECTED. OR ACCORDING TO LIMITED SAMPLE ( IF NEEDED, AND INSIDE VIEWING AREA )	Minor
ELECTRICAL	10. ELECTRICAL AND OPTICAL CHARACTERISTICS ( CONTRAST· VOP · CHROMATICITY ... ETC )	ACCORDING TO SPECIFICATION OR DRAWING . ( INSIDE VIEWING AREA )	Critical
	11.MISSING LINE	MISSING DOT · LINE · CHARACTER .....REJECTED	Critical
	12.SHORT CIRCUIT· WRONG PATTERN DISPLAY	NO DISPLAY · WRONG PATTERN DISPLAY · CURRENT CONSUMPTION OUT OF SPECIFICATION..... REJECTED	Critical
	13. DOT DEFECT (FOR COLOR AND TFT)	ACCORDING TO STANDARD OF VISUAL INSPECTION	Minor

## 11.4. STANDARD OF VISUAL INSPECTION

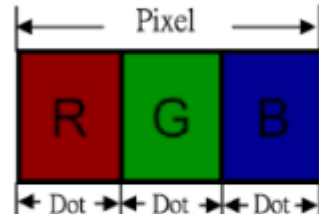
NO.	CLASS	ITEM	JUDGEMENT																				
11.4.1	MINOR	BLACK AND WHITE SPOT FOREIGN MATERIEL DUST IN THE CELL BLEMISH SCRATCH	<p>(A) ROUND TYPE: <span style="float: right;">unit : mm.</span></p> <table border="1"> <thead> <tr> <th>DIAMETER (mm.)</th> <th>ACCEPTABLE Q'TY</th> </tr> </thead> <tbody> <tr> <td><math>\Phi \leq 0.2</math></td> <td>DISREGARD</td> </tr> <tr> <td><math>0.2 &lt; \Phi \leq 0.4</math></td> <td>3 (Distance&gt;5mm)</td> </tr> <tr> <td><math>0.4 &lt; \Phi</math></td> <td>0</td> </tr> </tbody> </table> <p>NOTE: <math>\Phi = (\text{LENGTH} + \text{WIDTH}) / 2</math></p> <p>(B) LINEAR TYPE: <span style="float: right;">unit : mm.</span></p> <table border="1"> <thead> <tr> <th>LENGTH</th> <th>WIDTH</th> <th>ACCEPTABLE Q'TY</th> </tr> </thead> <tbody> <tr> <td>-----</td> <td><math>W \leq 0.05</math></td> <td>DISREGARD</td> </tr> <tr> <td><math>L \leq 5.0</math></td> <td><math>0.05 &lt; W \leq 0.08</math></td> <td>3 (Distance&gt;5mm)</td> </tr> <tr> <td>-----</td> <td><math>0.08 &lt; W</math></td> <td>FOLLOW ROUND TYPE</td> </tr> </tbody> </table>	DIAMETER (mm.)	ACCEPTABLE Q'TY	$\Phi \leq 0.2$	DISREGARD	$0.2 < \Phi \leq 0.4$	3 (Distance>5mm)	$0.4 < \Phi$	0	LENGTH	WIDTH	ACCEPTABLE Q'TY	-----	$W \leq 0.05$	DISREGARD	$L \leq 5.0$	$0.05 < W \leq 0.08$	3 (Distance>5mm)	-----	$0.08 < W$	FOLLOW ROUND TYPE
DIAMETER (mm.)	ACCEPTABLE Q'TY																						
$\Phi \leq 0.2$	DISREGARD																						
$0.2 < \Phi \leq 0.4$	3 (Distance>5mm)																						
$0.4 < \Phi$	0																						
LENGTH	WIDTH	ACCEPTABLE Q'TY																					
-----	$W \leq 0.05$	DISREGARD																					
$L \leq 5.0$	$0.05 < W \leq 0.08$	3 (Distance>5mm)																					
-----	$0.08 < W$	FOLLOW ROUND TYPE																					
11.4.2	MINOR	BUBBLE IN POLARIZER DENT ON POLARIZER	<p style="text-align: right;">unit : mm.</p> <table border="1"> <thead> <tr> <th>DIAMETER</th> <th>ACCEPTABLE Q'TY</th> </tr> </thead> <tbody> <tr> <td><math>\Phi \leq 0.3</math></td> <td>DISREGARD</td> </tr> <tr> <td><math>0.3 &lt; \Phi \leq 0.6</math></td> <td>3 (Distance&gt;7mm)</td> </tr> <tr> <td><math>0.6 &lt; \Phi</math></td> <td>0</td> </tr> </tbody> </table> <p style="text-align: center;">x</p>	DIAMETER	ACCEPTABLE Q'TY	$\Phi \leq 0.3$	DISREGARD	$0.3 < \Phi \leq 0.6$	3 (Distance>7mm)	$0.6 < \Phi$	0												
DIAMETER	ACCEPTABLE Q'TY																						
$\Phi \leq 0.3$	DISREGARD																						
$0.3 < \Phi \leq 0.6$	3 (Distance>7mm)																						
$0.6 < \Phi$	0																						
11.4.3	MINOR	Dot Defect	<table border="1"> <thead> <tr> <th>Items</th> <th>ACC. Q'TY</th> </tr> </thead> <tbody> <tr> <td>Bright dot</td> <td><math>N \leq 5</math></td> </tr> <tr> <td>Dark dot</td> <td><math>N \leq 5</math></td> </tr> </tbody> </table> <p>Pixel Define :</p>  <p>Note 1: The definition of dot: The size of a defective dot over 1/2 of whole dot is regarded as one defective dot.</p> <p>Note 2: Bright dot: Dots appear bright and unchanged in size in which LCD panel is displaying under black pattern.</p> <p>Note 3: Dark dot: Dots appear dark and unchanged in size in which LCD panel is displaying under pure red, green, blue pattern.</p>	Items	ACC. Q'TY	Bright dot	$N \leq 5$	Dark dot	$N \leq 5$														
Items	ACC. Q'TY																						
Bright dot	$N \leq 5$																						
Dark dot	$N \leq 5$																						

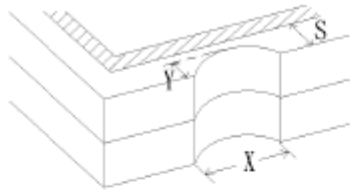
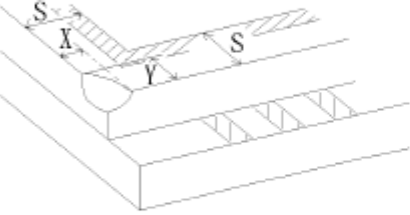
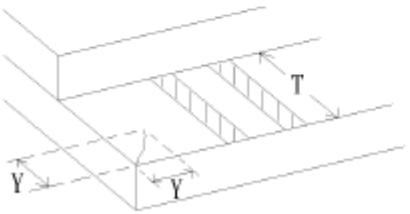
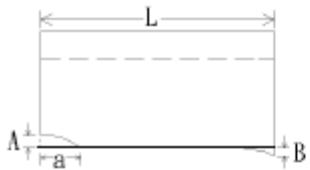
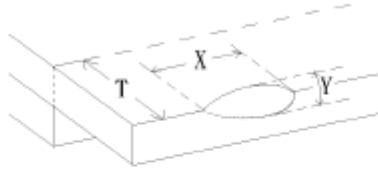
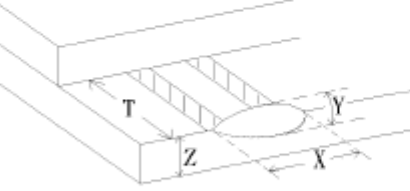
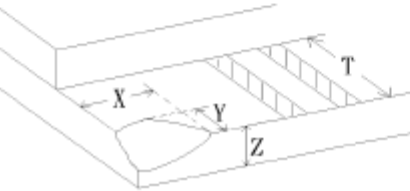
NO.	CLASS	ITEM	JUDGEMENT
11.4.4	MINOR	LCD GLASS CHIPPING	 $Y > S$ Reject
11.4.5	MINOR	LCD GLASS CHIPPING	 $X \text{ or } Y > S$ Reject
11.4.6	MAJOR	LCD GLASS GLASS CRACK	 $Y > (1/2) T$ Reject
11.4.7	MAJOR	LCD GLASS SCRIBE DEFECT	 <ol style="list-style-type: none"> <li><math>a &gt; L/3</math>, <math>A &gt; 1.5\text{mm}</math>. Reject</li> <li>B : ACCORDING TO DIMENSION</li> </ol>
11.4.8	MINOR	LCD GLASS CHIPPING ( ON THE TERMINAL AREA )	 $\Phi = (x+y)/2 > 2.5 \text{ mm}$ Reject
11.4.9	MINOR	LCD GLASS CHIPPING ( ON THE TERMINAL SURFACE )	 $Y > (1/3) T$ Reject
11.4.10	MINOR	LCD GLASS CHIPPING	 $Y > T$ Reject

## 12. Handling Precautions

### 12.1 Mounting method

The LCD panel of AMSON TFT module consists of two thin glass plates with polarizers which easily be damaged. And since the module is so constructed as to be fixed by utilizing fitting holes in the printed circuit board.

Extreme care should be needed when handling the LCD modules.

### 12.2 Caution of LCD handling and cleaning

When cleaning the display surface, Use soft cloth with solvent

[Recommended below] and wipe lightly

- Isopropyl alcohol
- Ethyl alcohol

Do not wipe the display surface with dry or hard materials that will damage the polarizer surface.

Do not use the following solvent:

- Water
- Aromatics

Do not wipe ITO pad area with the dry or hard materials that will damage the ITO patterns

Do not use the following solvent on the pad or prevent it from being contaminated:

- Soldering flux
- Chlorine (Cl) , Sulfur (S)

If goods were sent without being silicon coated on the pad, ITO patterns could be damaged due to the corrosion as time goes on.

If ITO corrosion happens by miss-handling or using some materials such as Chlorine (Cl), Sulfur (S) from customer, Responsibility is on customer.

### 12.3 Caution against static charge

The LCD module uses C-MOS LSI drivers, so we recommend that you:

Connect any unused input terminal to power or ground, do not input any signals before power is turned on, and ground your body, work/assembly areas, and assembly equipment to protect against static electricity.

### 12.4 packing

- Module employs LCD elements and must be treated as such.
- Avoid intense shock and falls from a height.
- To prevent modules from degradation, do not operate or store them exposed direct to sunshine or high temperature/humidity

### 12.5 Caution for operation

- It is an indispensable condition to drive LCD's within the specified voltage limit since the higher voltage than the limit causes the shorter LCD life.
- An electrochemical reaction due to direct current causes LCD's undesirable deterioration, so that the use of direct current drive should be avoided.
- Response time will be extremely delayed at lower temperature than the operating temperature range and on the other hand at higher temperature LCD's show dark color in them. However those phenomena do not mean malfunction or out of order with LCD's, which will come back in the specified operation temperature.
- If the display area is pushed hard during operation, some font will be abnormally displayed but it resumes normal condition after turning off once.
- Slight dew depositing on terminals is a cause for electro-chemical reaction resulting in terminal open circuit.

Usage under the maximum operating temperature, 50%Rh or less is required.



## 12.6 storing

In the case of storing for a long period of time for instance, for years for the purpose or replacement use, the following ways are recommended.

- Storage in a polyethylene bag with the opening sealed so as not to enter fresh air outside in it. And with no desiccant.
- Placing in a dark place where neither exposure to direct sunlight nor light's keeping the storage temperature range.
- Storing with no touch on polarizer surface by the anything else.  
[It is recommended to store them as they have been contained in the inner container at the time of delivery from us.]

## 12.7 Safety

- It is recommendable to crash damaged or unnecessary LCD's into pieces and wash off liquid crystal by either of solvents such as acetone and ethanol, which should be burned up later.
- When any liquid leaked out of a damaged glass cell comes in contact with your hands, please wash it off well with soap and water.

## 13. Precaution for Use

### 13.1

A limit sample should be provided by the both parties on an occasion when the both parties agreed its necessity. Judgment by a limit sample shall take effect after the limit sample has been established and confirmed by the both parties.

### 13.2

On the following occasions, the handing of problem should be decided through discussion and agreement between responsible of the both parties.

- When a question is arisen in this specification.
- When a new problem is arisen this is not specified in this specification.
- When an inspection specifications change or operating condition change in customer is reported to AMSON TFT and some problem is arisen in this specification due to the change.
- When a new problem is arisen at the customer's operating set for sample evaluation in the customer site.

## 14. Packing Method

TBD