

Specification for Approval

Customer: _____

Model Name: _____

Supplier Approval			Customer approval
R&D Designed	R&D Approved	QC Approved	
<i>Peter</i>	<i>Peng Jun</i>		



Revision Record

REV NO.	REV DATE	CONTENTS	Note
A	2021-08-13	NEW ISSUE	

Table of Contents

List	Description	Page No.
	Cover	1
	Revision Record	2
	Table of Contents	3
1	Scope	4
2	General Information	4
3	External Dimensions	5
4	Interface Description	6
5	Absolute Maximum Ratings	7
6	DC Characteristics	7
7	Timing Characteristics	8
8	Backlight Characteristics	13
9	Optical Characteristics	14
10	Reliability Test Conditions and Methods	16
11	Inspection Standard	17
12	Handling Precautions	22
13	Precaution for Use	23
14	Packing Method	23

1. Scope

This specification defines general provisions as well as inspection standards for TFT module supplied by AMSON electronics.

If the event of unforeseen problem or unspecified items may occur, naturally shall negotiate and agree to solution.

2. General Information

ITEM	STANDARD VALUES	UNITS
LCD type	10.1" TFT	--
Dot arrangement	1024×3 (RGB)×600	dots
Color filter array	RGB vertical stripe	--
Display mode	Normally BLACK	--
Viewing Direction	ALL VIEWING	--
Module size	235(W)×143(H)×4.5(T)	mm
Active area	222.72(W)×125.28(H)	mm
Dot pitch	0.2175(W)×0.2088(H)	mm
Interface	TTL	--
Operating temperature	-20 ~ +70	°C
Storage temperature	-30 ~ +80	°C

4. Interface Description

PIN	PIN NAME	DESCRIPTION
1~2	NC	Not connect.
3~4	NC	Not connect.
5	GND	Power ground
6	VCOM	Common Voltage.
7	DVDD	Digital Power.
8	MODE	DE/SYNC mode select. Normally pull high. H: DE mode. L: SYNC mode.
9	DE	Data Enable signal.
10	VS	Vertical sync input. Negative polarity.
11	HS	Horizontal sync input. Negative polarity.
12	B7	Blue Data Input (MSB).
13~18	B6~B1	Blue Data Input.
19	B0	Blue Data Input (LSB).
20	G7	Green Data Input (MSB).
21~26	G6~G1	Green Data Input.
27	G0	Green Data Input (LSB).
28	R7	Red Data Input (MSB).
29~34	R6	Red Data Input.
35	R0	Red Data Input (LSB).
36	GND	Power ground.
37	DCLK	Clock input.
38	GND	Power ground.
39	L/R	Left/Right scan setting. Normally pull high. When L/R=L, reverse scan. When L/R=H, normal scan. (Default)
40	U/D	Up/down scan setting. Normally pull low. When U/D=H, reverse scan. When U/D=L, normal scan. (Default)
41	VGH	Positive Power for TFT Gate on.
42	VGL	Negative Power for TFT Gate off.
43	AVDD	Analog Power Supply.
44	RESET	Global reset pin. Active low to enter reset state. Suggest to connecting with an RC reset circuit for stability. Normally pull high.(R=10KΩ, C=1μF)
45	NC.	Not connect.
46	VCOM	Common Voltage.
47	DITHB	Dithering function enable control. (Normally pull high) DITHB="L", to enable internal dithering function. DITHB="H", to disable internal dithering function.
48	GND	Power ground.
49	NC.	Not connect.
50	NC.	Not connect.

5. Absolute Maximum Ratings

Item	Symbol	Min.	Max.	Unit
Digital Supply Voltage	DVDD	-0.5	5	V
Analog Supply Voltage	AVDD	-0.5	15	V
Gate On Voltage	VGH	-0.5	40	V
Gate Off Voltage	VGL	-20	0.3	V
Operating Temperature	T _{OP}	-20	70	°C
Storage Temperature	T _{ST}	-30	80	°C
Storage Humidity	HD	10	90	%RH

6. DC Characteristics

Item	Symbol	Min.	Typ.	Max.	Unit	Remark
Digital Supply Voltage	DVDD	3.0	3.3	3.6	V	-
Analog Supply Voltage	AVDD	11.7	12.2	12.7	V	-
Gate On Voltage	VGH	19.0	22.0	25.0	V	-
Gate Off Voltage	VGL	-13.0	-10.0	-7.0	V	-
Common Voltage	VCOM	4.39	5.39	6.39	V	NOTE1
Logic Input Voltage	V _{IH}	0.7DVDD	-	DVDD	V	-
	V _{IL}	GND	-	0.3DVDD	V	-

NOTE1: VCOM 电压根据客户主板实际效果而定

7. Timing Characteristics

7.1 Power ON/OFF Sequence

In order to prevent IC from power on reset fail, the rising time (TPOR) of the digital power supply VDD should be maintained within the given specifications. Refer to “AC Characteristics” for more detail on timing.

7.1.1 Power on/off timing sequence

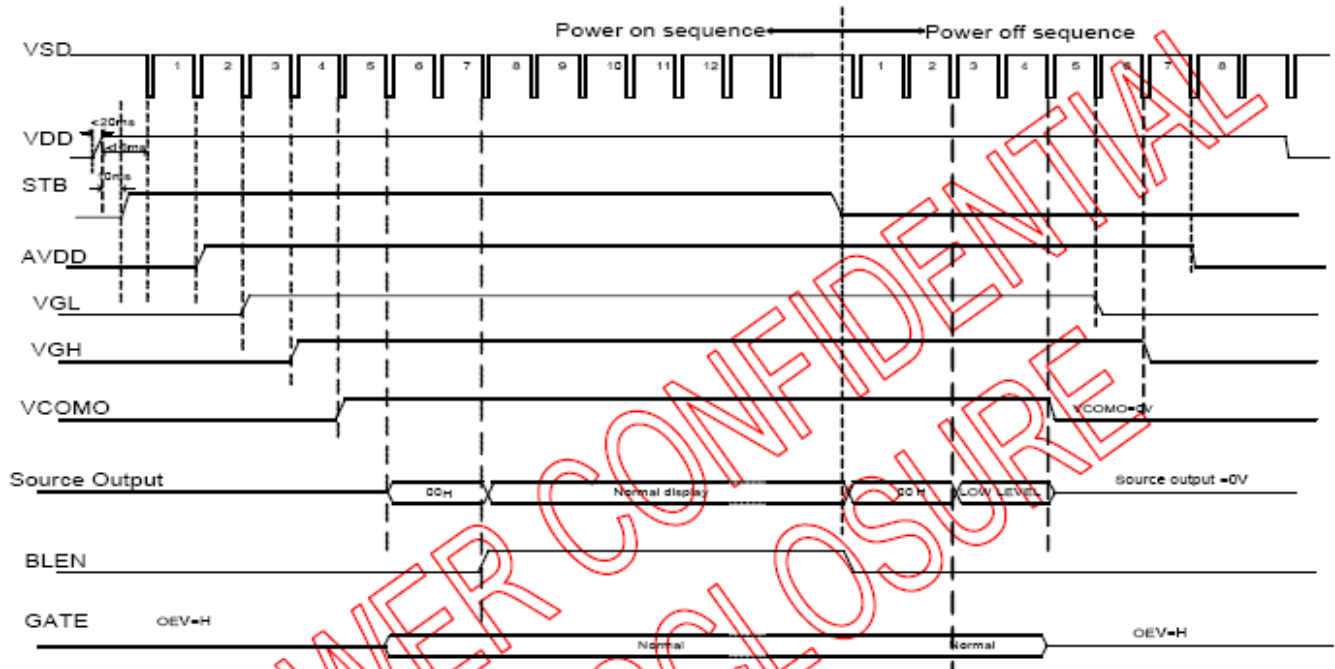

Power On/Off timing chart

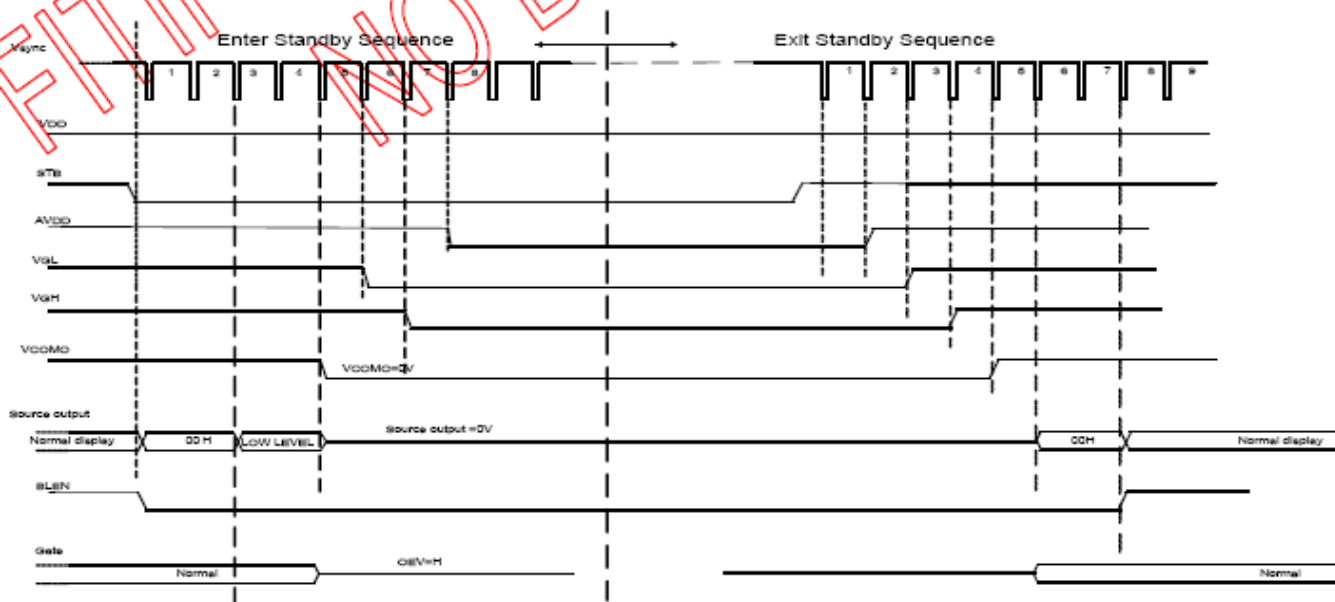

Enter and Exit Standby Mode timing chart

7.2 AC Electrical Characteristics

TTL mode AC electrical characteristics

(TA = -20 to 85°C, VDD = 2.3 to 3.6V, AVDD = 8 to 13.5V, GND = AGND = 0V)

TTL mode

Parameter	Symbol	Condition	Min.	Typ.	Max.	Unit
VDD Power On Slew rate	TPOR	From 0V to 90% VDD	1	-	20	ms
RST pulse width	TRST	DCLK = 65MHz	50	-	-	us
DCLK cycle time	Tcph	-	14	-	-	ns
DCLK pulse duty	Tcwh	-	40	50	60	%
VSD setup time	Tvst	-	5	-	-	ns
VSD hold time	Tvhd	-	5	-	-	ns
HSD setup time	Thst	-	5	-	-	ns
HSD hold time	Thhd	-	5	-	-	ns
Data set-up time	Tdsu	D0[7:0], D1[7:0], D2[7:0] to DCLK	5	-	-	ns
Data hold time	Tdhd	D0[7:0], D1[7:0], D2[7:0] to DCLK	5	-	-	ns
DE setup time	Tesu	-	5	-	-	ns
DE hold time	Tehd	-	5	-	-	ns
Output stable time	Tsst	Dual gate	-	-	3	us

Input clock and data timing diagram

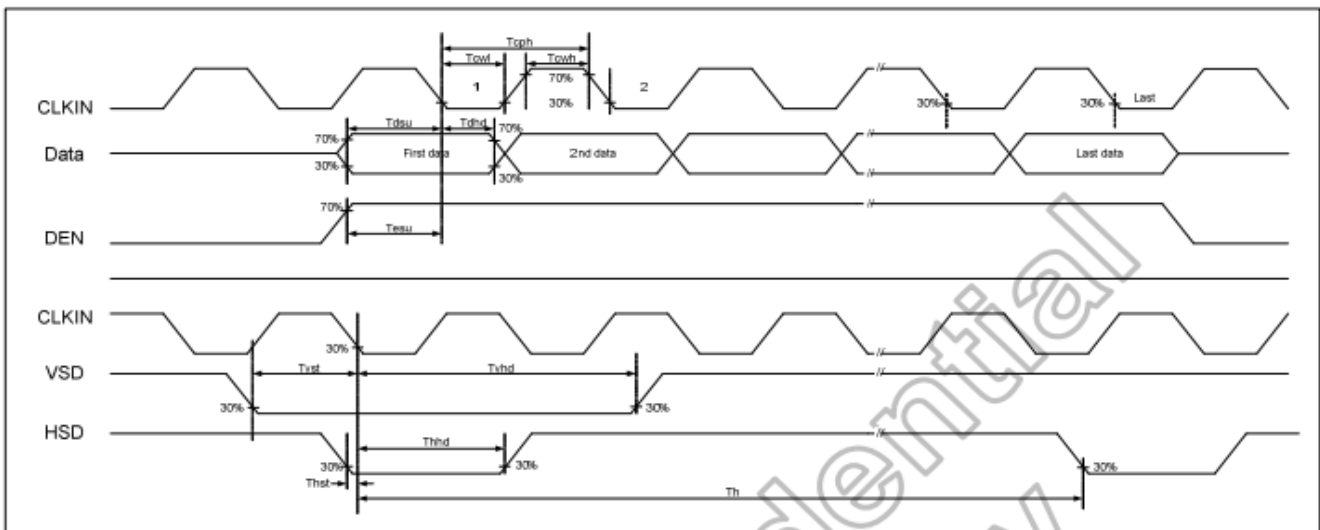

7.3 TTL mode data input format

(TA = -20 to 85°C, VDD = 2.3 to 3.6V, AVDD = 8 to 13.5V, GND = AGND = 0V)

TTL mode

Parameter	Symbol	Condition	Min.	Typ.	Max.	Unit
VDD Power On Slew rate	TPOR	From 0V to 90% VDD	1	-	20	ms
RST pulse width	TRST	DCLK = 65MHz	50	-	-	us
DCLK cycle time	Tcph	-	14	-	-	ns
DCLK pulse duty	Tcwh	-	40	50	60	%
VSD setup time	Tvst	-	5	-	-	ns
VSD hold time	Tvhd	-	5	-	-	ns
HSD setup time	Thst	-	5	-	-	ns
HSD hold time	Thhd	-	5	-	-	ns
Data set-up time	Tdsu	D0[7:0], D1[7:0], D2[7:0] to DCLK	5	-	-	ns
Data hold time	Tdhd	D0[7:0], D1[7:0], D2[7:0] to DCLK	5	-	-	ns
DE setup time	Tesu	-	5	-	-	ns
DE hold time	Tehd	-	5	-	-	ns
Output stable time	Tsst	Dual gate	-	-	3	us

7.4 Parallel RGB input timing table

6.7.1. Vertical input timing

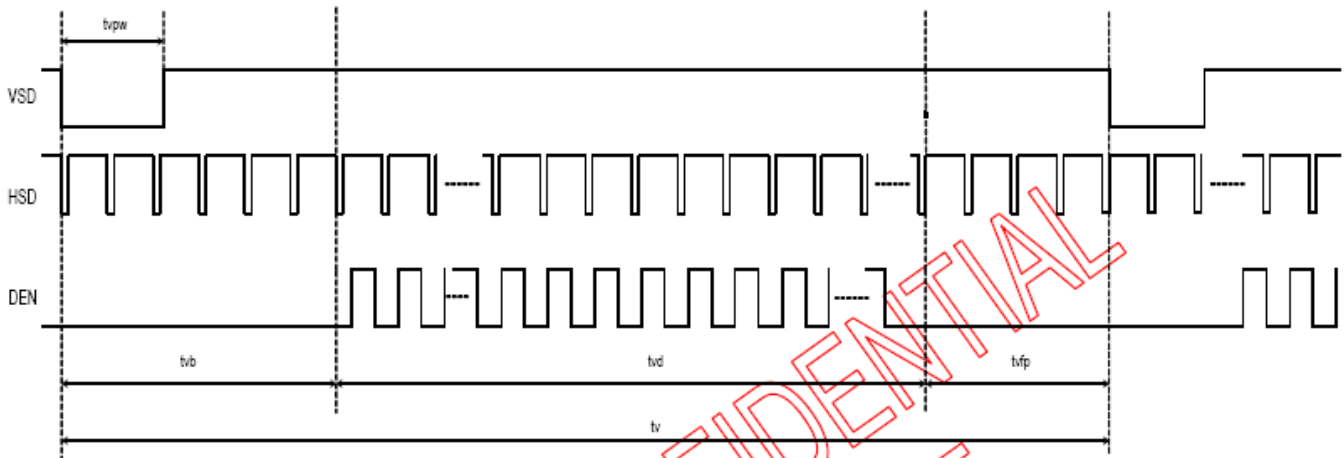

6.7.2. Horizontal input timing

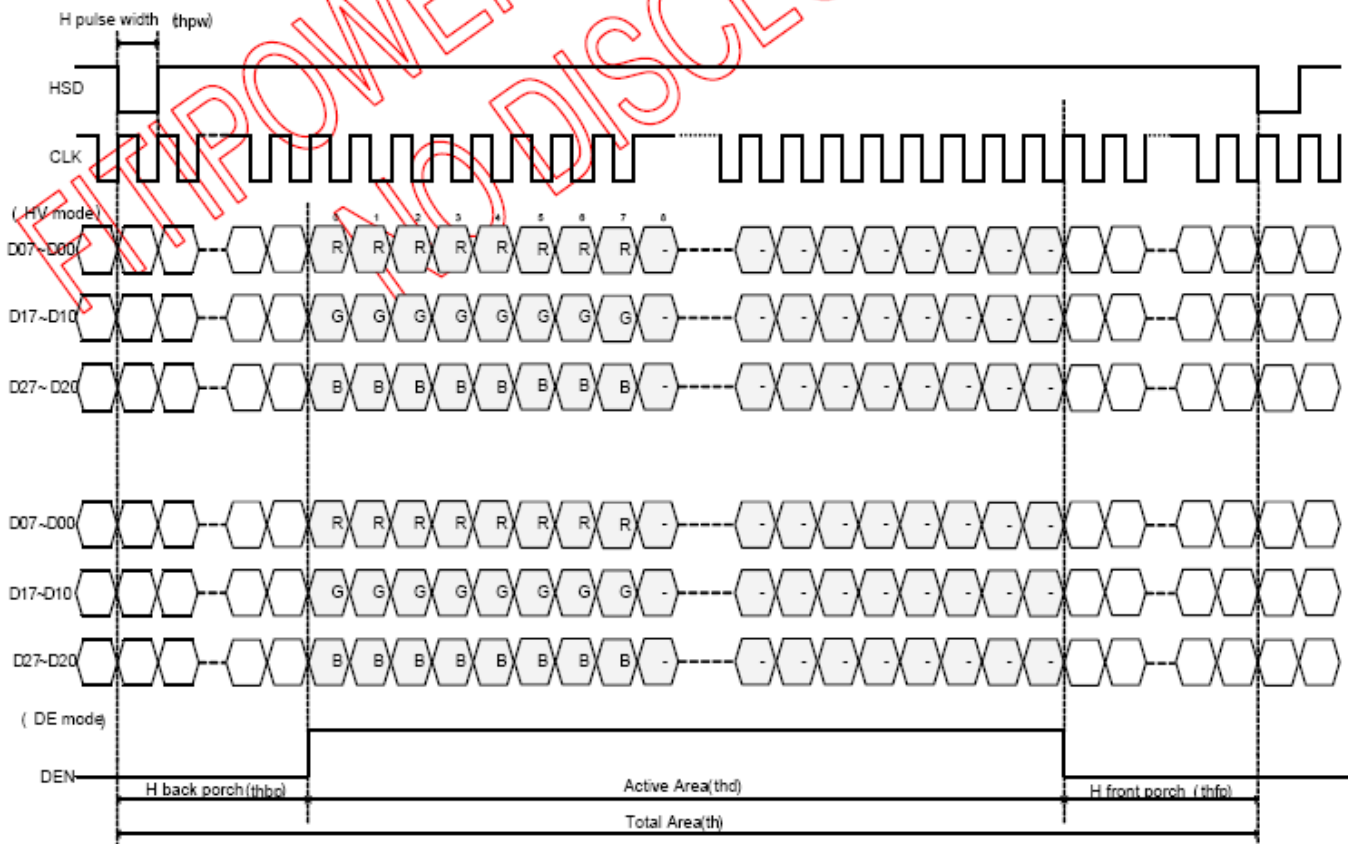

DE mode

Parameter	Symbol	Value			Unit
		Min.	Typ.	Max.	
DCLK frequency @Frame rate=60hz	fclk	40.8	51.2	67.2	Mhz
Horizontal display area	thd	1024			DCLK
HSYNC period time	th	1114	1344	1400	DCLK
HSYNC blanking	thb+thfp	90	320	376	DCLK
Vertical display area	tvd	600			H
VSYNC period time	tv	610	635	800	H
VSYNC blanking	tvb+tvfp	10	35	200	H

HV mode(1)

HV mode Horizontal input timing						
Parameter		Symbol	Value			Unit
Horizontal display area		thd	1024			DCLK
DCLK frequency@ Frame rate=60hz		fclk	Min.	Typ.	Max.	Mhz
			44.9	51.2	63	
1 Horizontal Line		th	1200	1344	1400	DCLK
HSYNC pulse width	Min.	thpw	1			
	Typ.		-			
	Max.		140			
HSYNC back porch		thbp	160	160	160	
HSYNC front porch		thfp	16	160	216	

HV mode(2)

Vertical input timing					
Parameter	Symbol	Value			Unit
		Min.	Typ.	Max.	
Vertical display area	tvd	600			H
VSYNC period time	tv	624	635	750	H
VSYNC pulse width	tvpw	1	-	20	H
VSYNC back porch	tvb	23	23	23	H
VSYNC front porch	tvfp	1	12	127	H

8. Backlight Characteristic

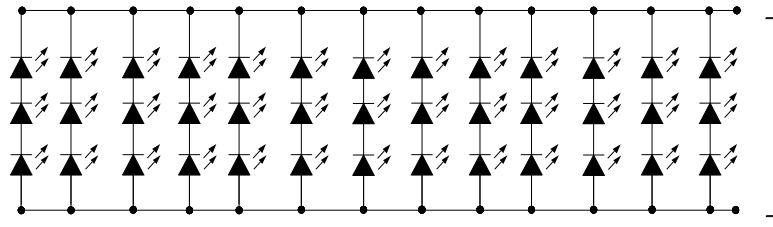

Item	Symbol	MIN	TYP	MAX	UNIT	Test Condition
Supply Voltage	Vf	9	9.6	10.5	V	If=260mA
Supply Current	If	-	260	-	mA	If=260mA
Luminous Intensity for LCM	-	300	350	-	cd/m ²	If=260mA
Uniformity for LCM	-	75	-	-	%	If=260mA
Life Time	-	30000	-	-	Hr	If=260mA

9. Optical Characteristics

Item	Conditions	Min.	Typ.	Max.	Unit	Note	
Viewing Angle (CR>10)	Horizontal	θ_L	80	85	-	degree	(1),(2),(6)
		θ_R	80	85	-		
	Vertical	θ_T	80	85	-		
		θ_B	80	85	-		
Contrast Ratio	Center	600	800	-	-	(1),(3),(6)	
Response Time	Rising + Falling	-	30	45	ms	(1),(4),(6)	
CF Color Chromaticity (CIE1931)	Red x	Typ. -0.02	0.601	Typ. +0.02	-	(1), (6)	
	Red y		0.328		-		
	Green x		0.288		-		
	Green y		0.517		-		
	Blue x		0.150		-		
	Blue y		0.144		-		
	White x		0.302		-		
	White y		0.324		-		

Note (1) Measurement Setup: The LCD module should be stabilized at given temp. 25°C for 15 minutes to avoid abrupt temperature change during measuring. In order to stabilize the luminance, the measurement should be executed after lighting backlight for 15 minutes in a windless room.

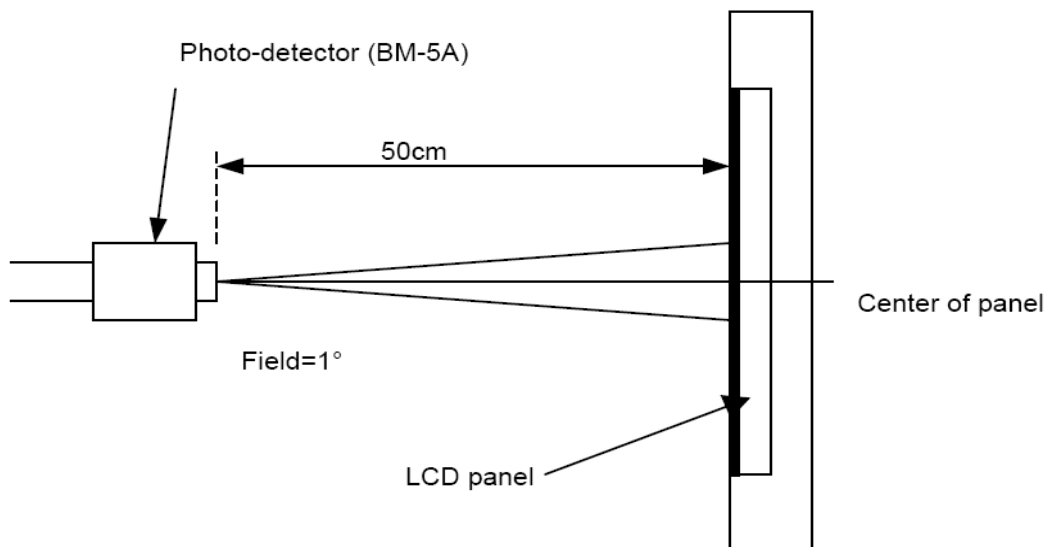

Note (2) Definition of Viewing Angle

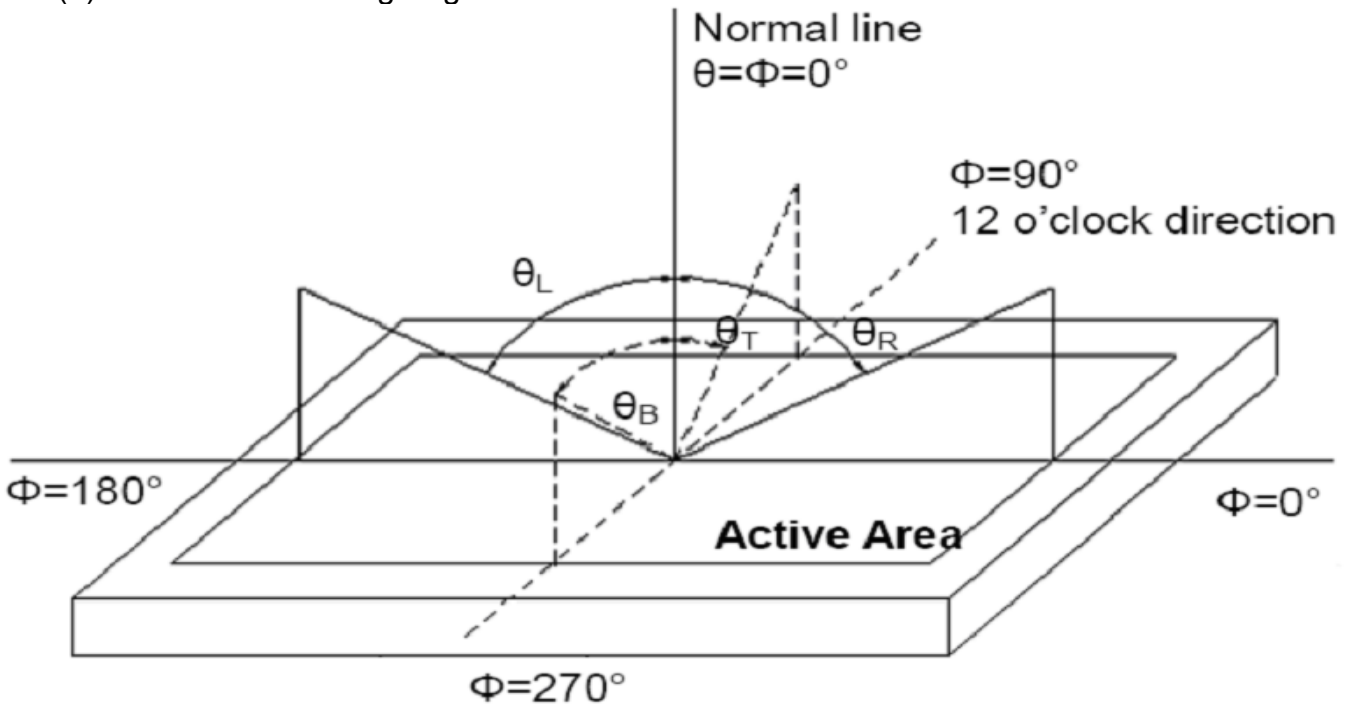

Note (3) Definition of Contrast Ratio (CR)

The contrast ratio can be calculated by the following expression

$$\text{Contrast Ratio (CR)} = L_{63} / L_0$$

L63: Luminance of gray level 63, L0: Luminance of gray level 0

Note (4) Definition of response time

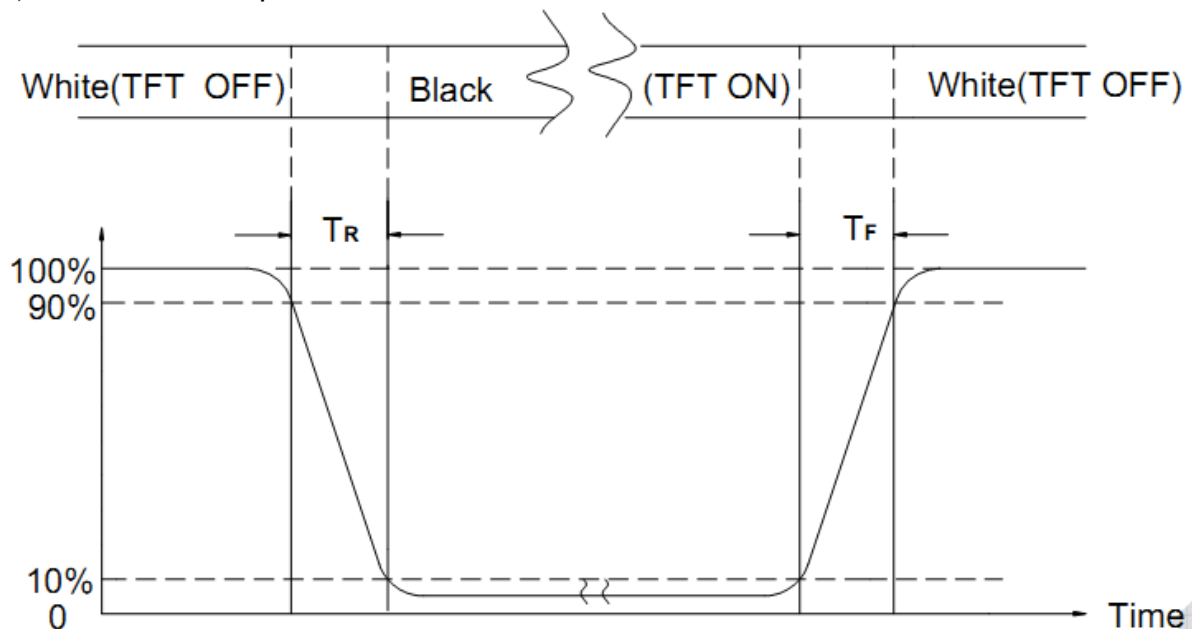

Note (5) Definition of Transmittance (Module is without signal input)

$$\text{Transmittance} = \text{Center Luminance of LCD} / \text{Center Luminance of Back Light} \times 100\%$$

Note (6) Definition of color chromaticity (CIE1931)

Color coordinates measured at the center point of LCD

10. Reliability Test Conditions and Methods

NO.	TEST ITEMS	TEST CONDITION											
①	High Temperature Storage	Keep in 80°C ±5°C 240 hrs Surrounding temperature, then storage at normal condition 4hrs.											
②	Low Temperature Storage	Keep in -30°C ±5°C 240 hrs Surrounding temperature, then storage at normal condition 4hrs.											
③	High Temperature / High Humidity Storage Test	Keep in 60 °C / 90% R.H duration for 240 hrs Surrounding temperature, then storage at normal condition 4hrs. (Excluding the polarizer)											
④	Temperature Cycling Storage Test	<p style="text-align: center;"> -30°C → +25°C → 80°C → +25°C (30mins) (5mins) (30mins) (5mins) ↔ 30 Cycle </p> Surrounding temperature, then storage at normal condition 4hrs.											
⑤	ESD Test	Air Discharge: Apply 2 KV with 5 times Discharge for each polarity +/-	Contact Discharge: Apply 250 V with 5 times discharge for each polarity +/-										
		1. Temperature ambience : 15°C ~ 35°C 2. Humidity relative : 30% ~ 60% 3. Energy Storage Capacitance(Cs + Cd) : 150pF±10% 4. Discharge Resistance(Rd) : 330Ω±10% 5. Discharge, mode of operation : Single Discharge (time between successive discharges at least 1 sec) (Tolerance if the output voltage indication : ±5%)											
⑥	Vibration Test (Packaged)	1. Sine wave 10~55 Hz frequency (1 min/sweep) 2. The amplitude of vibration :1.5 mm 3. Each direction (X、Y、Z) duration for 2 Hrs											
⑦	Drop Test (Packaged)	<table border="1" style="margin-left: auto; margin-right: auto;"> <thead> <tr> <th>Packing Weight (Kg)</th> <th>Drop Height (cm)</th> </tr> </thead> <tbody> <tr> <td>0 ~ 45.4</td> <td>122</td> </tr> <tr> <td>45.4 ~ 90.8</td> <td>76</td> </tr> <tr> <td>90.8 ~ 454</td> <td>61</td> </tr> <tr> <td>Over 454</td> <td>46</td> </tr> </tbody> </table> <p>Drop Direction :※1 corner / 3 edges / 6 sides each 1time</p>		Packing Weight (Kg)	Drop Height (cm)	0 ~ 45.4	122	45.4 ~ 90.8	76	90.8 ~ 454	61	Over 454	46
Packing Weight (Kg)	Drop Height (cm)												
0 ~ 45.4	122												
45.4 ~ 90.8	76												
90.8 ~ 454	61												
Over 454	46												

11. Inspection Standard

11.1. QUALITY :

THE QUALITY OF GOODS SUPPLIED TO PURCHASER SHALL COME UP TO THE FOLLOWING STANDARD.

11.1.1. INSPECTION TOOLS AND INSTRUMENTS

Vernier calipers, film scales, multimeter, magnifying eyepiece, ND5%, luminance meter and so on.

11.1.2. THE METHOD OF PRESERVING GOODS

AFTER DELIVERY OF GOODS FROM AMSON TO PURCHASER. PURCHASER SHALL CONTROL THE LCM AT -10 TO 40 ,AND IT MIGHT BE DESIRABLE TO KEEP AT THE NORMAL ROOM TEMPERATURE AND HUMIDITY UNTIL INCOMING INSPECTION OR THROWING INTO PROCESS LINE.

11.1.3. INCOMING INSPECTION

(A) THE METHOD OF INSPECTION

IF PURCHASER MAKE AN INCOMING INSPECTION , A SAMPLING PLAN SHALL BE APPLIED ON THE CONDITION THAT QUALITY OF ONE DELIVERY SHALL BE REGARDED AS ONE LOT.

(B) THE STANDARD OF QUALITY

ISO-2859-1 (SAME AS MIL-STD-105E) ,LEVEL:II

CLASS	AQL(%)
CRITICAL	0.4 %
MAJOR	0.65 %
MINOR	1.5 %

EVERY ITEM SHALL BE INSPECTED ACCORDING TO THE CLASS.

(C) MEASURE

IF AS THE RESULT OF ABOVE RECEIVING INSPECTION , A LOT OUT IS DISCOVERED. PURCHASER SHALL BE INFORM SELLER OF IT WITHIN SEVEN DAYS. BUT FIRST SHIPMENT WITHIN FOURTEEN DAYS.

11.1.4. WARRANTY POLICY

AMSON WILL PROVIDE ONE-YEAR WARRANTY FOR THE PRODUCTS ONLY IF UNDER SPECIFICATION OPERATING CONDITIONS. AMSON WILL REPLACE NEW PRODUCTS FOR THESE DEFECT PRODUCTS WHICH UNDER WARRANTY PERIOD AND BELONG TO THE RESPONSIBILITY OF AMSON.

11.2. CHECKING CONDITION

11.2.1.CHECKING DIRECTION SHALL BE IN THE 45 DEGREE AREA TO FACE THE SAMPLE.

11.2.2.CHECKER SHALL SEE OVER 300±25 mm. WITH BARE EYES FAR FROM SAMPLE

11.2.3.Ambient Illumination:

0 ~30 Lux for functional inspection

500 ~ 1200 Lux for external appearance inspection.

11.2.4. TEST AREA:

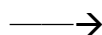

11.2.5. Inspection should be carried out with rope electrostatic ring and static finger cover (both hands except small fingers must be worn)

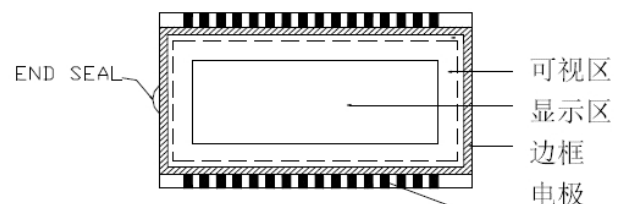

11.2.6. The inspector may make a visual inspection or a comparative examination with a film

ruler and a magnifying eyepiece. Individual defects shall be determined according to the limited samples.

11.2.7. Functional testing uses electrical testing fixtures or test fixtures required by customers.

11.2.8. the ion fan should be used when testing.

11.2.9. the principle of judgment

11.3.1 If the defect outside the visual area does not affect the assembly and display, it will be judged as a good product.

11.3.2 Poor definition

Pixel:

A combination of three sub-pixels (Red + Green + Blue).

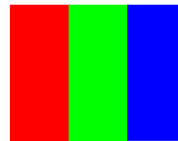

Dot:

Any of the sub-pixels (Red or Green or Blue).



Bright and dark dots:

A point pixel (sub-pixel: R, G, B pixels) is lit or turned off during the display function test.

Highlights:

Usually considered to be shown on a black screen.

Dark spots:

They are generally considered to be shown on R, G, B solid colors or white images.

Neighborhood:

Two or three adjacent point pixels (dot: sub-pixel) connected together (R, G or G, B or B, R or RGB).

11.3. INSPECTION PLAN :

CLASS	ITEM	JUDGEMENT	CLASS
PACKING & INDICATE	1. OUTSIDE AND INSIDE PACKAGE	"MODEL NO." , "LOT NO." AND "QUANTITY" SHOULD INDICATE ON THE PACKAGE.	Minor
	2. MODEL MIXED AND QUANTITY	OTHER MODEL MIXED.....REJECTED QUANTITY SHORT OR OVER.....REJECTED	Critical
	3. PRODUCT INDICATION	"MODEL NO." SHOULD INDICATE ON THE PRODUCT	Major
ASSEMBLY	4. DIMENSION, LCD GLASS SCRATCH AND SCRIBE DEFECT.	ACCORDING TO SPECIFICATION OR DRAWING.	Major
APPEARANCE	5. VIEWING AREA	POLARIZER EDGE OR LCD'S SEALING LINE IS VISABLE IN THE VIEWING AREAREJECTED	Minor
	6. BLEMISH · BLACK SPOT · WHITE SPOT IN THE LCD AND LCD GLASS CRACKS	ACCORDING TO STANDARD OF VISUAL INSPECTION(INSIDE VIEWING AREA)	Minor
	7. BLEMISH · BLACK SPOT WHITE SPOT AND SCRATCH ON THE POLARIZER	ACCORDING TO STANDARD OF VISUAL INSPECTION(INSIDE VIEWING AREA)	Minor
	8. BUBBLE IN POLARIZER	ACCORDING TO STANDARD OF VISUAL INSPECTION(INSIDE VIEWING AREA)	Minor
	9. LCD'S RAINBOW COLOR	STRONG DEVIATION COLOR (OR NEWTON RING) OF LCD.....REJECTED. OR ACCORDING TO LIMITED SAMPLE (IF NEEDED, AND INSIDE VIEWING AREA)	Minor
ELECTRICAL	10. ELECTRICAL AND OPTICAL CHARACTERISTICS (CONTRAST· VOP · CHROMATICITY ... ETC)	ACCORDING TO SPECIFICATION OR DRAWING . (INSIDE VIEWING AREA)	Critical
	11.MISSING LINE	MISSING DOT · LINE · CHARACTERREJECTED	Critical
	12.SHORT CIRCUIT· WRONG PATTERN DISPLAY	NO DISPLAY · WRONG PATTERN DISPLAY · CURRENT CONSUMPTION OUT OF SPECIFICATION..... REJECTED	Critical
	13. DOT DEFECT (FOR COLOR AND TFT)	ACCORDING TO STANDARD OF VISUAL INSPECTION	Minor

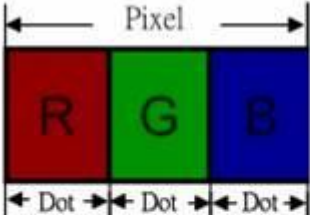
NO.	CLASS	ITEM	JUDGEMENT																				
11.4.1	MINOR	BLACK AND WHITE SPOT FOREIGN MATERIEL DUST IN THE CELL BLEMISH SCRATCH	<p>(A) ROUND TYPE: unit : mm.</p> <table border="1"> <thead> <tr> <th>DIAMETER (mm.)</th> <th>ACCEPTABLE Q'TY</th> </tr> </thead> <tbody> <tr> <td>$\Phi \leq 0.15$</td> <td>Distance>1mm</td> </tr> <tr> <td>$0.15 < \Phi \leq 0.4$</td> <td>3 (Distance>15mm)</td> </tr> <tr> <td>$0.4 < \Phi$</td> <td>0</td> </tr> </tbody> </table> <p>NOTE: $\Phi=(\text{LENGTH}+\text{WIDTH})/2$</p> <p>(B) LINEAR TYPE: unit : mm.</p> <table border="1"> <thead> <tr> <th>LENGTH</th> <th>WIDTH</th> <th>ACCEPTABLE Q'TY</th> </tr> </thead> <tbody> <tr> <td>-----</td> <td>$W \leq 0.03$</td> <td>Distance>1mm</td> </tr> <tr> <td>$L \leq 4.0$</td> <td>$0.03 < W \leq 0.05$</td> <td>3 (Distance>15mm)</td> </tr> <tr> <td>-----</td> <td>$0.05 < W$</td> <td>FOLLOW ROUND TYPE</td> </tr> </tbody> </table>	DIAMETER (mm.)	ACCEPTABLE Q'TY	$\Phi \leq 0.15$	Distance>1mm	$0.15 < \Phi \leq 0.4$	3 (Distance>15mm)	$0.4 < \Phi$	0	LENGTH	WIDTH	ACCEPTABLE Q'TY	-----	$W \leq 0.03$	Distance>1mm	$L \leq 4.0$	$0.03 < W \leq 0.05$	3 (Distance>15mm)	-----	$0.05 < W$	FOLLOW ROUND TYPE
DIAMETER (mm.)	ACCEPTABLE Q'TY																						
$\Phi \leq 0.15$	Distance>1mm																						
$0.15 < \Phi \leq 0.4$	3 (Distance>15mm)																						
$0.4 < \Phi$	0																						
LENGTH	WIDTH	ACCEPTABLE Q'TY																					
-----	$W \leq 0.03$	Distance>1mm																					
$L \leq 4.0$	$0.03 < W \leq 0.05$	3 (Distance>15mm)																					
-----	$0.05 < W$	FOLLOW ROUND TYPE																					
11.4.2	MINOR	BUBBLE IN POLARIZER DENT ON POLARIZER	<p style="text-align: right;">unit : mm.</p> <table border="1"> <thead> <tr> <th>DIAMETER</th> <th>ACCEPTABLE Q'TY</th> </tr> </thead> <tbody> <tr> <td>$\Phi \leq 0.2$</td> <td>Distance>1mm</td> </tr> <tr> <td>$0.2 < \Phi \leq 0.5$</td> <td>3 (Distance>15mm)</td> </tr> <tr> <td>$0.5 < \Phi$</td> <td>0</td> </tr> </tbody> </table>	DIAMETER	ACCEPTABLE Q'TY	$\Phi \leq 0.2$	Distance>1mm	$0.2 < \Phi \leq 0.5$	3 (Distance>15mm)	$0.5 < \Phi$	0												
DIAMETER	ACCEPTABLE Q'TY																						
$\Phi \leq 0.2$	Distance>1mm																						
$0.2 < \Phi \leq 0.5$	3 (Distance>15mm)																						
$0.5 < \Phi$	0																						
11.4.3	MINOR	Dot Defect	<table border="1"> <thead> <tr> <th>Items</th> <th>ACC. Q'TY</th> </tr> </thead> <tbody> <tr> <td>Bright dot</td> <td>$N \leq 2$ (Distance>15mm)</td> </tr> <tr> <td>Dark dot</td> <td>$N \leq 3$ (Distance>15mm)</td> </tr> </tbody> </table> <p>Pixel Define :</p>  <p>Note 1: The definition of dot: The size of a defective dot over 1/2 of whole dot is regarded as one defective dot. Definition:<1/2dot and visible by 5% ND filter $N \leq 5$</p> <p>Note 2: Bright dot: Dots appear bright and unchanged in size in which LCD panel is displaying under black pattern.</p> <p>Note 3: Dark dot: Dots appear dark and unchanged in size in which LCD panel is displaying under pure red, green ,blue pattern.</p>	Items	ACC. Q'TY	Bright dot	$N \leq 2$ (Distance>15mm)	Dark dot	$N \leq 3$ (Distance>15mm)														
Items	ACC. Q'TY																						
Bright dot	$N \leq 2$ (Distance>15mm)																						
Dark dot	$N \leq 3$ (Distance>15mm)																						
11.4.4	MINOR	Mura	Not visible through 5% ND filter in 50% gray or judge by limit sample if necessary																				

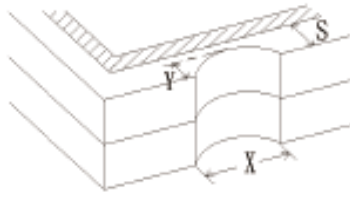
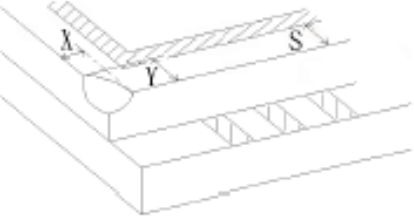
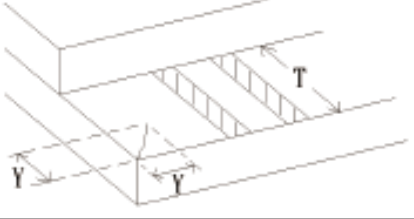
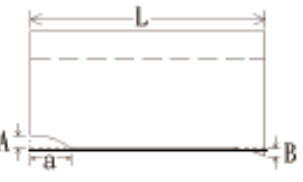
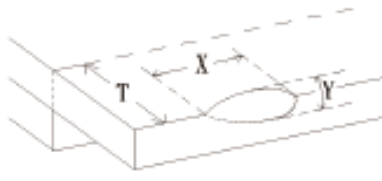
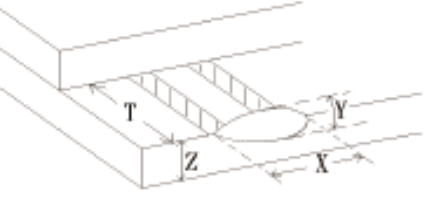
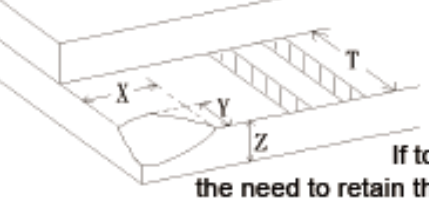
NO.	CLASS	ITEM	JUDGEMENT
11.4.5	MINOR	LCD GLASS CHIPPING	 <p>$X \geq 3\text{mm}$ $Y > S$</p> <p>Reject</p>
11.4.6	MINOR	LCD GLASS CHIPPING	 <p>$X \text{ or } Y > S$</p> <p>Reject</p>
11.4.7	MAJOR	LCD GLASS GLASS CRACK	 <p>Continuous burst NG</p> <p>Reject</p>
11.4.8	MAJOR	LCD GLASS SCRIBE DEFECT	 <p>ACCORDING TO DIMENSION</p>
11.4.9	MINOR	LCD GLASS CHIPPING (ON THE TERMINAL AREA)	 <p>$Y < 1/2Z$ $Y \geq 0.5\text{mm}$ $X \geq 3\text{mm}$</p> <p>Reject</p>
11.4.10	MINOR	LCD GLASS CHIPPING (ON THE TERMINAL SURFACE)	 <p>$Y < 1/2Z$ $Y \geq 0.5\text{mm}$ $X \geq 3\text{mm}$</p> <p>Reject</p>
11.4.11	MINOR	LCD GLASS CHIPPING	 <p>$X \geq 3\text{mm}$ $Y \geq T$</p> <p>Reject</p> <p>If touch the electrode lines, the need to retain the two-thirds electrode lines</p>

12. Handling Precautions

12.1 Mounting method

The LCD panel of AMSON TFT module consists of two thin glass plates with polarizers which easily be damaged. And since the module is so constructed as to be fixed by utilizing fitting holes in the printed circuit board.

Extreme care should be needed when handling the LCD modules.

12.2 Caution of LCD handling and cleaning

When cleaning the display surface, Use soft cloth with solvent

[Recommended below] and wipe lightly

- Isopropyl alcohol
- Ethyl alcohol

Do not wipe the display surface with dry or hard materials that will damage the polarizer surface.

Do not use the following solvent:

- Water
- Aromatics

Do not wipe ITO pad area with the dry or hard materials that will damage the ITO patterns

Do not use the following solvent on the pad or prevent it from being contaminated:

- Soldering flux
- Chlorine (Cl) , Sulfur (S)

If goods were sent without being silicon coated on the pad, ITO patterns could be damaged due to the corrosion as time goes on.

If ITO corrosion happens by miss-handling or using some materials such as Chlorine (Cl), Sulfur (S) from customer, Responsibility is on customer.

12.3 Caution against static charge

The LCD module uses C-MOS LSI drivers, so we recommend that you:

Connect any unused input terminal to power or ground, do not input any signals before power is turned on, and ground your body, work/assembly areas, and assembly equipment to protect against static electricity.

12.4 packing

- Module employs LCD elements and must be treated as such.
- Avoid intense shock and falls from a height.
- To prevent modules from degradation, do not operate or store them exposed direct to sunshine or high temperature/humidity

12.5 Caution for operation

- It is an indispensable condition to drive LCD's within the specified voltage limit since the higher voltage than the limit causes the shorter LCD life.
- An electrochemical reaction due to direct current causes LCD's undesirable deterioration, so that the use of direct current drive should be avoided.
- Response time will be extremely delayed at lower temperature than the operating temperature range and on the other hand at higher temperature LCD's show dark color in them. However those phenomena do not mean malfunction or out of order with LCD's, which will come back in the specified operation temperature.
- If the display area is pushed hard during operation, some font will be abnormally displayed but it resumes normal condition after turning off once.
- Slight dew depositing on terminals is a cause for electro-chemical reaction resulting in terminal open circuit.

Usage under the maximum operating temperature, 50%Rh or less is required.

12.6 storing

In the case of storing for a long period of time for instance, for years for the purpose or replacement use, the following ways are recommended.

- Storage in a polyethylene bag with the opening sealed so as not to enter fresh air outside in it. And with no desiccant.
- Placing in a dark place where neither exposure to direct sunlight nor light's keeping the storage temperature range.
- Storing with no touch on polarizer surface by the anything else.
[It is recommended to store them as they have been contained in the inner container at the time of delivery from us.]

12.7 Safety

- It is recommendable to crash damaged or unnecessary LCD's into pieces and wash off liquid crystal by either of solvents such as acetone and ethanol, which should be burned up later.
- When any liquid leaked out of a damaged glass cell comes in contact with your hands, please wash it off well with soap and water.

13. Precaution for Use

13.1

A limit sample should be provided by the both parties on an occasion when the both parties agreed its necessity. Judgment by a limit sample shall take effect after the limit sample has been established and confirmed by the both parties.

13.2

On the following occasions, the handing of problem should be decided through discussion and agreement between responsible of the both parties.

- When a question is arisen in this specification.
- When a new problem is arisen this is not specified in this specification.
- When an inspection specifications change or operating condition change in customer is reported to AMSON TFT and some problem is arisen in this specification due to the change.
- When a new problem is arisen at the customer's operating set for sample evaluation in the customer site.

14. Packing Method

TBD