

# Specification for Approval

Customer: \_\_\_\_\_

Model Name: \_\_\_\_\_

Supplier Approval			Customer approval
R&D Designed	R&D Approved	QC Approved	
<i>Peter</i>	<i>Peng Jun</i>		

# Revision Record

REV NO.	REV DATE	CONTENTS	Note
A	2024-12-30	NEW ISSUE	

## Contents

No.	Items	Page
1.0	General Description	4
2.0	Absolute Maximum ratings	6
3.0	Electrical specifications.	7
4.0	Interface Connection	9
5.0	Signal Timing Specifications	12
6.0	DC Specification	13
7.0	Power Sequence	14
8.0	Optical specifications.	15
9.0	Mechanical Outline Dimension	19
10.0	Reliability Test	21
11.0	Precautions	22
12.0	Label	26
13.0	Packing information	28

## 1.0 GENERAL DESCRIPTION

### 1.0.1 Introduction

AM-1024768-121E is a color active matrix TFT LCD module using amorphous silicon TFT's (Thin Film Transistors) as an active switching devices. This module has a 12.1 inch diagonally measured active area with XGA resolutions (1024 horizontal by 768 vertical pixel array). Each pixel is divided into RED, GREEN, BLUE dots which are arranged in vertical stripe and this module can display 16.7 M colors.

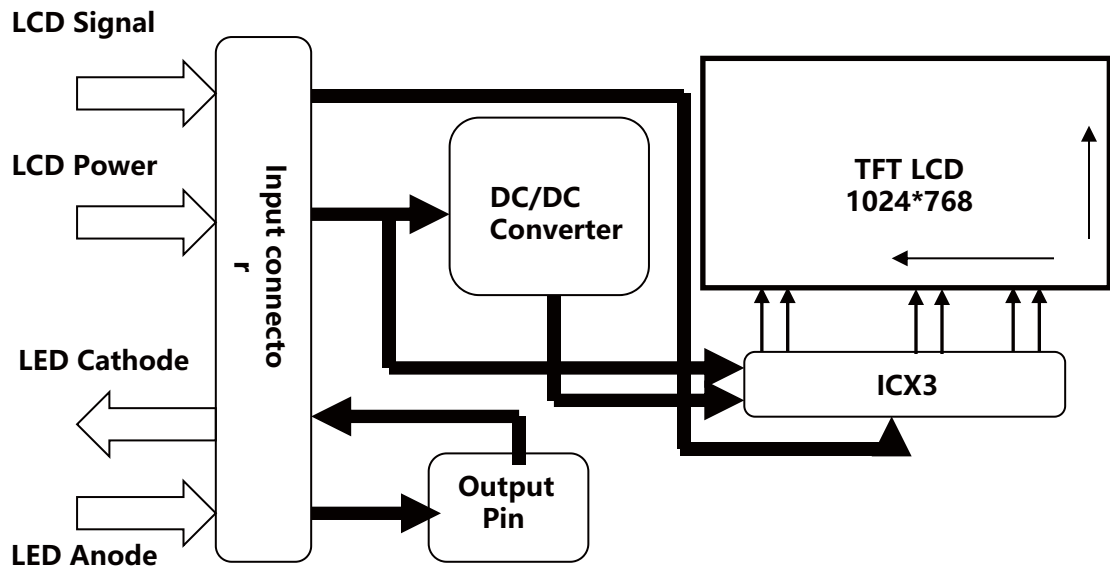

### 1.0.2 Features

- LVDS interface
- GOA Design

### 1.0.3 Application

- Industrial lathe / Colour ultrasonography / Charging pile etc.

## 1.0.4 General Specification(H: horizontal length, V: vertical length)

< Table 1. General Specifications >

Parameter	Specification	Unit	Remarks
Active area	245.76 (H) × 184.32(V)	mm	
Number of pixels	1024 (H) × 768 (V)	Pixels	
Pixel pitch	0.08 (H)× 0.24 (V)	mm	
<b>MDL Outline</b>	260.5(W)×204(V)×8.7(D)±0.5	mm	
Pixel arrangement	RGB Vertical stripe		
Display colors	16.7M	Colors	
Display mode	Normally Black		
AA-Panel edge(L/R/U/D)	3.5/3.5/3.5/6.6	mm	
Luminance	Typ. 500 nit; Min 400nit	nit	
Color Gamut	Typ. 72% ; Min 67%		
Contrast Ratio	Typ.1200; Min 900		
Response Time	Typ. 30;Max 35	ms	
Viewing Angle(U/D/L/R)	Typ.: 88/88/88/88	Deg.	

## 2.0 ABSOLUTE MAXIMUM RATINGS

The followings are maximum values which, if exceed, may cause faulty operation or damage to the unit. The operational and non-operational maximum voltage and current values are listed in Table 2.

< Table 2. Environment Absolute Maximum Ratings> [Ta =25±2 °C]

Parameter	Symbol	Values			Unit	Notes
		Min.	Typ.	Max.		
LCD Panel Signal Processing Board	VDD	-0.3	-	3.96	V	Ta = 25 °C
Operating Temperature	T <sub>OP</sub>	-20	-	70	°C	Note2
Storage Temperature	T <sub>ST</sub>	-30	-	80	°C	
Operating Ambient Humidity	H <sub>op</sub>	10	-	90	%RH	
Storage Humidity	H <sub>st</sub>	10	-	90	%RH	
Run time		-	-	168	H	

Note:

1.AMSON is not responsible for product problems beyond the use conditions.

2.When the ambient temperature is T °C, the surface temperature of Panel can not exceed (T+15)°C.

### 3.0 ELECTRICAL SPECIFICATIONS

#### 3.0.1 TFT LCD Module

< Table 3. LCD Module Electrical Specifications >

[Ta =25±2 °C]

Parameter	Symbol	Values			Unit	Notes
		Min.	Typ.	Max.		
LCD Panel Signal Processing Board	VDD	3.0	3.3	3.6	V	Note1
LCD Panel Signal Current	I <sub>DD</sub>	220	235	500	mA	
In-Rush Current	I <sub>RUSH</sub>	-	-	3	A	
LCD Panel Display Power	P	0.72	0.78	1.65	W	Note1

Note :

1. The supply voltage is measured and specified at the interface connector of LCM.The current draw and power consumption specified is for VDD=3.3V, Frame rate=60Hz Clock frequency =64.99MHz. Test Pattern of power supply current

a)Typ : Mosaic 8 x 6 Pattern(L0/L255)

b)Max : Skip-Subpixel-255

a) Typ : Mosaic 8 x 6 Pattern(L0/L255)

b) Skip-Subpixel-255

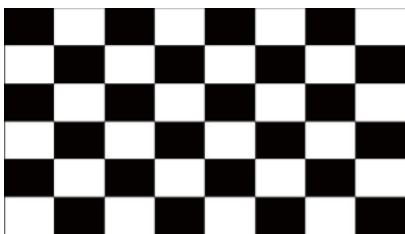

3.0.2 Back-light Unit

< Table 4. LED Driving guideline specifications >

Ta=25+/-2°C

Parameter	Symbol	Values			Unit	Notes	
		Min.	Typ.	Max.			
Backlight Input Voltage	VLED	11	12	20	V		
Backlight Input Current	I <sub>LED</sub>	-	480	-	mA		
Backlight Power	PLED	-	9.6	-	W	Note 1	
BLU on/off Level	BLU on	2.0	-	-	V		
	BLU off	0	-	0.8	V		
PWMIN	Level	High Level	2.0	-	-	V	
		Low Level	0	-	0.8	V	
	Frequency	F <sub>PWM</sub>	200	-	10000	Hz	
	Duty Ratio	D <sub>PWM</sub>	10	-	100	%	
LED Life Time	TLED	50000	-	-	Hrs	Note 2/3	

Notes:

1.  $PLED = VLED \times I_{LED}$

2.The life time of LED, 50,000Hrs, is determined as the time at which luminance of the LED is 50% compared to that of initial value at the typical LED current on condition of continuous operating at 25 ± 2°C.

3.Only under the above operating conditions could the life time of LED be guaranteed.



## 4.0 INTERFACE CONNECTION.

### 4.0.1 Electrical Interface Connection

The electronics interface connector is 9006F20-0048RQ-G4.

The LED connector is 91208-01001-H01(ACES)

The connector interface pin assignments are listed in Table 5 and 6.

<Table 5. Pin Assignments for the Interface Connector>

Terminal	Symbol	Functions
Pin No.	Symbol	Description
1	RX3+	Differential Data Input,CH3(Positive)
2	RX3-	Differential Data Input,CH3(Negative)
3	NC	Non connection
4	NC	Non connection
5	GND	Ground
6	RXC+	Differential Clock Input(Positive)
7	RXC-	Differential Clock Input(Negative)
8	GND	Ground
9	RX2+	Differential Data Input,CH2(Positive)
10	RX2-	Differential Data Input,CH2(Negative)
11	GND	Ground
12	RX1+	Differential Data Input,CH1(Positive)
13	RX1-	Differential Data Input,CH1(Negative)
14	GND	Ground
15	RX0+	Differential Data Input,CH0(Positive)
16	RX0-	Differential Data Input,CH0(Negative)
17	NC	this pin should be open
18	NC	this pin should be open
19	VCC	3.3V Power supply
20	VCC	3.3V Power supply

<Table 6. Pin Assignments for the LED Connector>

Terminal	Symbol	Functions
Pin No.	Symbol	Description
1	VI	12V
2	VI	12V
3	VI	12V
4	VI	12V
5	GND	Ground
6	GND	Ground
7	GND	Ground
8	GND	Ground
9	EN	Enable
10	PWM	Backlight Adjust, PWM Dimming

## 4.0.2 Data Input Format

**Figure 1. Pixel Format**

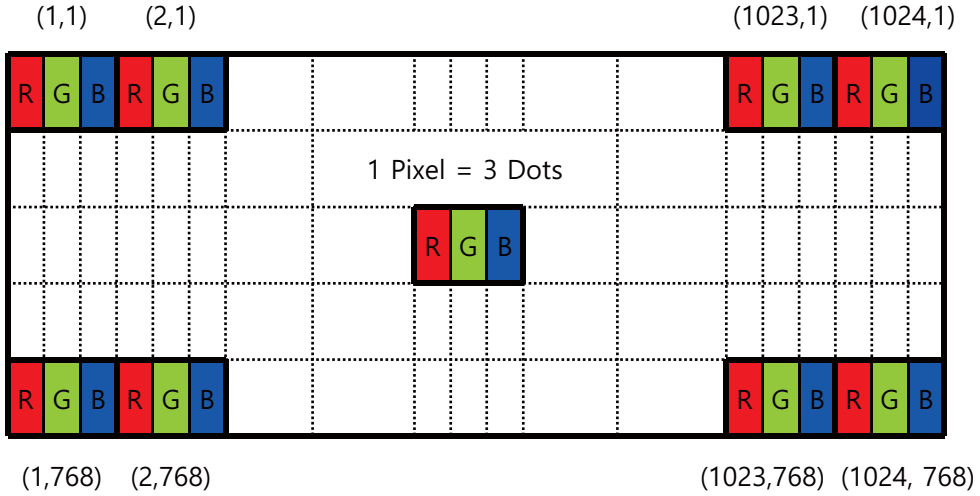

Display Position of Input Data (V-H)

**Figure 2. Scan direction**

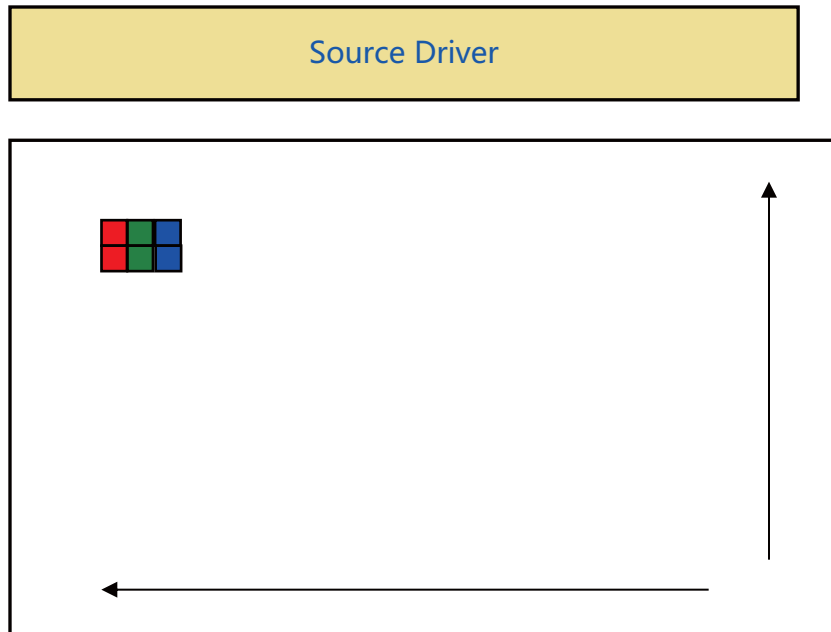

## 5.0 SIGNAL TIMING SPECIFICATION

### 5.0.1 The AM-1024768-121E is operated by the DE only.

<Table 7. SIGNAL TIMING Specification>

Item		Symbol	min	typ	max	UNIT	
LCD	Frame Rate	-	55	60	65	Hz	
	Pixels Rate	-	59.6	64.9	70.4	MHz	
Timing	Horizontal	Horizontal total time	tHP	1284	1344	1404	t <sub>CLK</sub>
		Horizontal Active time	tHadr	1024			t <sub>CLK</sub>
		Horizontal Back Porch	tHBP	110	130	150	t <sub>CLK</sub>
		Horizontal Front Porch	tHFP	110	130	150	t <sub>CLK</sub>
		Horizontal Pulse Width	tHsync	40	60	80	t <sub>CLK</sub>
	Vertical	Vertical total time	tvp	798	806	844	tH
		Vertical Active time	tVadr	768			tH
		Vertical Back Porch	tVBP	20	23	40	tH
		Vertical Front Porch	tVFP	8	11	28	tH
		Vertical Pulse Width	tVsync	2	4	8	tH
Lane			-	4	-	Lane	

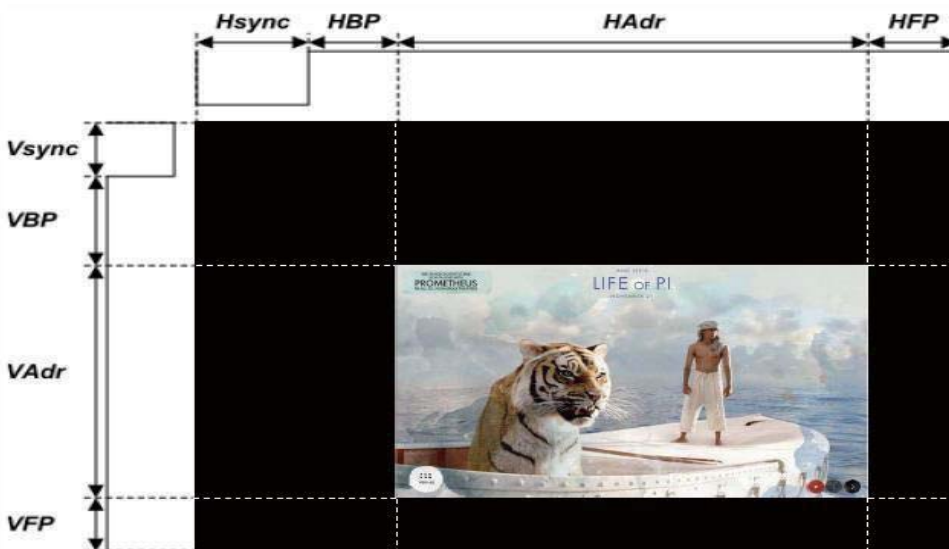

## 6.0 DC Specification

<Table 8. DC Specification>

Parameter	Symbol	Min	Typ	Max	Unit	Condition
Supply current	$I_{DD}$	-	100	-	mA	
<b>LVDS DC specifications</b>						
Differential input high threshold	$V_{TH}$	-	-	+100	mV	$V_{IC}=1.2V$
Differential input low threshold	$V_{TL}$	-100	-	-	mV	
LVDS common mode voltage	$V_{IC}$	0.7	-	1.6	V	
LVDS swing voltage	$V_{ID}$	$\pm 100$	-	$\pm 600$	mV	
<b>Mini-LVDS DC specifications</b>						
Output differential voltage range	$V_{OD}$	$\pm 170$	$\pm 200$	$\pm 230$	mV	$PI=14K\Omega$ $RL=100\Omega$ $(T_A=25^\circ C)$
Output differential voltage deviation		410	-	590	mV	
Output offset voltage range	$V_{OS}$	1.0	1.2	1.4	V	

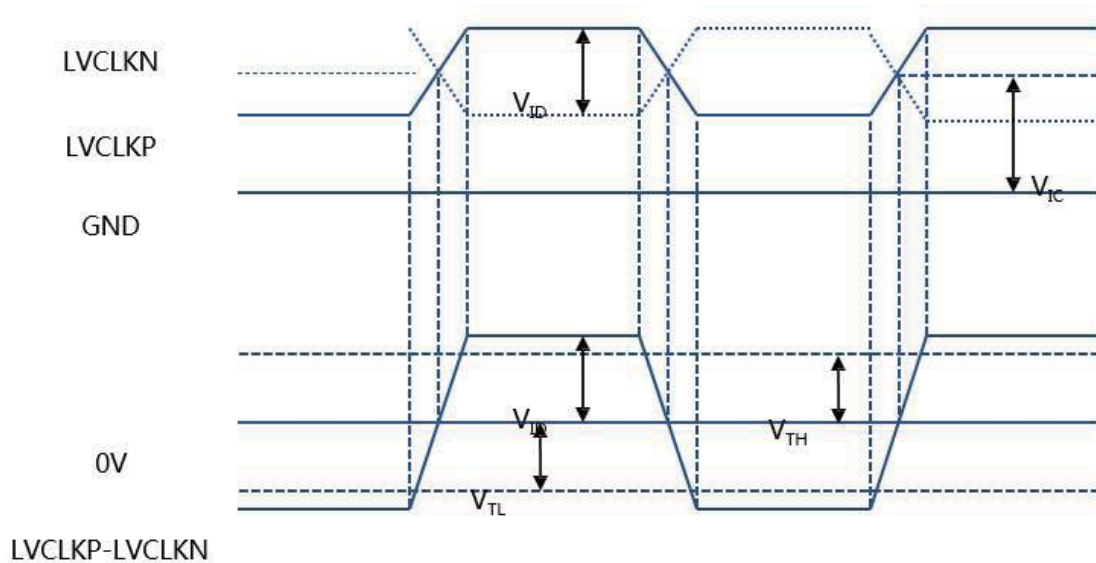

< LVDS  $V_{ID}$  and  $V_{IC}$  definition >

## 7.0 POWER SEQUENCE

To prevent a latch-up or DC operation of the LCD module, the power on/off sequence shall be as shown in below

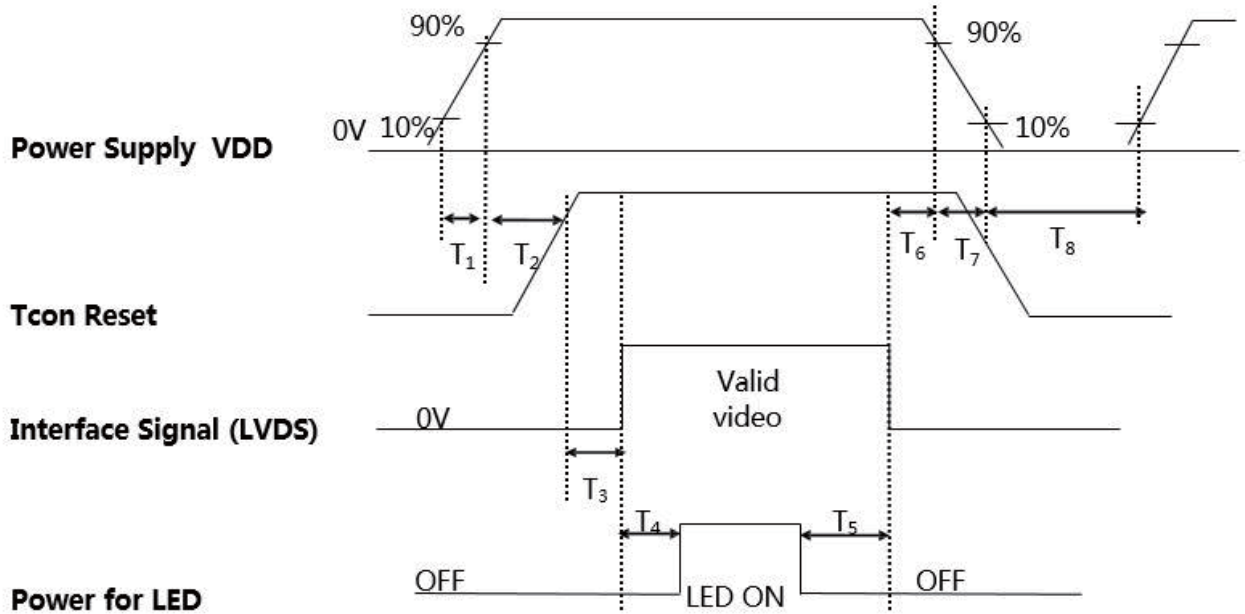

Parameter	Value			Units
	Min.	Typ.	Max.	
T1	0.1	-	8	(ms)
T2	-	8	-	(ms)
T3	0	-	-	(ms)
T4	300	-	-	(ms)
T5	300	-	-	(ms)
T6	0	-	50	(ms)
T7	0	-	10	(ms)
T8	500	-	-	(ms)

## 8.0 OPTICAL SPECIFICATION

### 8.0.1 Overview

The test of view angle range shall be measured in a dark room (ambient luminance  $\leq 1$ lux and temperature =  $25\pm 2^\circ\text{C}$ ) with the equipment of Luminance meter system (Goniometer system and TOPCON CS2000/CA310) and test unit shall be located at an approximate distance 50cm from the LCD surface at a viewing angle of  $\theta$  and  $\Phi$  equal to  $0^\circ$ . We refer to  $\theta\Phi=0$  ( $=\theta_3$ ) as the 3 o'clock direction (the "right"),  $\theta\Phi=90$  ( $=\theta_{12}$ ) as the 12 o'clock direction ("upward"),  $\theta\Phi=180$  ( $=\theta_9$ ) as the 9 o'clock direction ("left") and  $\theta\Phi=270$  ( $=\theta_6$ ) as the 6 o'clock direction ("bottom"). While scanning  $\theta$  and/or  $\Phi$ , the center of the measuring spot on the Display surface shall stay fixed. The luminance, color and uniformity (etc) should be tested by CS2000/CA310. The backlight should be operating for 10 minutes prior to measurement. VDD shall be  $3.3 \pm 0.3\text{V}$  at  $25^\circ\text{C}$ . Optimum viewing angle direction is 6 'clock

<Table 9. Optical Specifications>

Parameter		Symbol	Condition	Min.	Typ.	Max.	Unit	Remark
Viewing Angle range	Horizontal	$\Theta_3$	CR > 10	80	88	-	Deg.	Note 1
		$\Theta_9$		80	88	-	Deg.	
	Vertical	$\Theta_{12}$		80	88	-	Deg.	
		$\Theta_6$		80	88	-	Deg.	
Luminance Contrast ratio		CR	$\Theta = 0^\circ$	900	1200	-		Note 2
Luminance of White	Center	$Y_w$	$\Theta = 0^\circ$	400	500	-	cd/m <sup>2</sup>	Note 3
White Luminance uniformity	9 Points	$\Delta Y_9$		75	80	-	%	Note 4
Color Gamut	NTSC	CIE1931	$\Theta = 0^\circ$	67	72	-	%	Note 5
Reproduction of color	White	$W_x$	$\Theta = 0^\circ$	Typ -0.05	0.313	Typ +0.05		
		$W_y$			0.329			
	Red	$R_x$			0.652			
		$R_y$			0.338			
	Green	$G_x$			0.324			
		$G_y$			0.607			
	Blue	$B_x$			0.153			
		$B_y$			0.048			
Response Time		Tr+Td	Ta= $25^\circ\text{C}$ $\Theta = 0^\circ$	-	30	35	ms	Note 6

- Notes :
1. Viewing angle is the angle at which the contrast ratio is greater than 10. The viewing angles are determined for the horizontal or 3, 9 o'clock direction and the vertical or 6, 12 o'clock direction with respect to the optical axis which is normal to the LCD surface (see FIGURE 3).
  2. Contrast measurements shall be made at viewing angle of  $\Theta = 0$  and at the center of the LCD surface. Luminance shall be measured with all pixels in the view field set first to white, then to the dark (black) state. (see FIGURE 3) Luminance Contrast Ratio (CR) is defined mathematically.

$$CR = \frac{\text{Luminance when displaying a white raster}}{\text{Luminance when displaying a black raster}}$$

3. Luminance of white is defined as luminance values of center of the LCD surface. Luminance shall be measured with all pixels in the view field set first to white. This measurement shall be taken at the locations shown in FIGURE 4 for a total of the measurements per display. The luminance is measured by CS2000/CA310 when the LED current is set at 60mA.
4. The White luminance uniformity on LCD surface is then expressed as :  $\Delta Y = \frac{\text{Minimum Luminance of 9 points}}{\text{Maximum Luminance of 9 points}}$  (See FIGURE 4).
5. The color chromaticity coordinates specified in Table 5. shall be calculated from the spectral data measured with all pixels first in red, green, blue and white. Measurements shall be made at the center of the panel.
6. The electro-optical response time measurements shall be made as FIGURE 5 by switching the "data" input signal ON and OFF. The times needed for the luminance to change from 10% to 90% is  $T_r$ , and 90% to 10% is  $T_d$ .



8.0.2 Optical measurements

Figure 3. Measurement Set Up

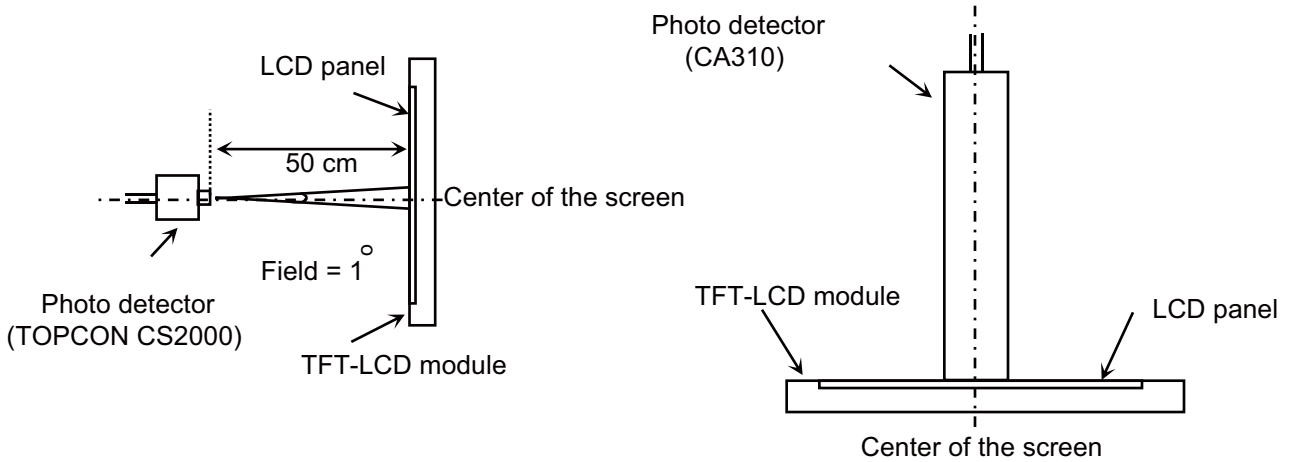

View angel range, uniformity, etc. measurement setup    Flicker, measurement setup

Figure 4. White Luminance and Uniformity Measurement Locations (9 points)

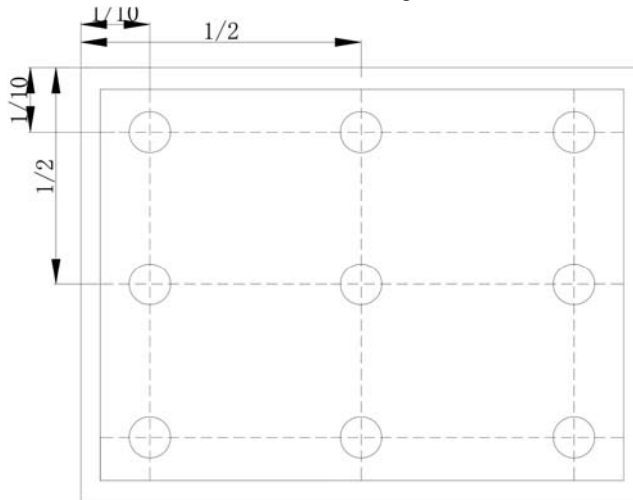

Luminance of white is defined as luminance values of center of the LCD surface. Luminance shall be measured with all pixels in the view field set first to white. This measurement shall be taken at the locations shown in FIGURE 4 for a total of the measurements per display.

The White luminance uniformity on LCD surface is then expressed as :  $\Delta Y9 = \text{Minimum Luminance of 9 points} / \text{Maximum Luminance of 9points}$  (see FIGURE4).

**Figure 5. Response Time Testing**

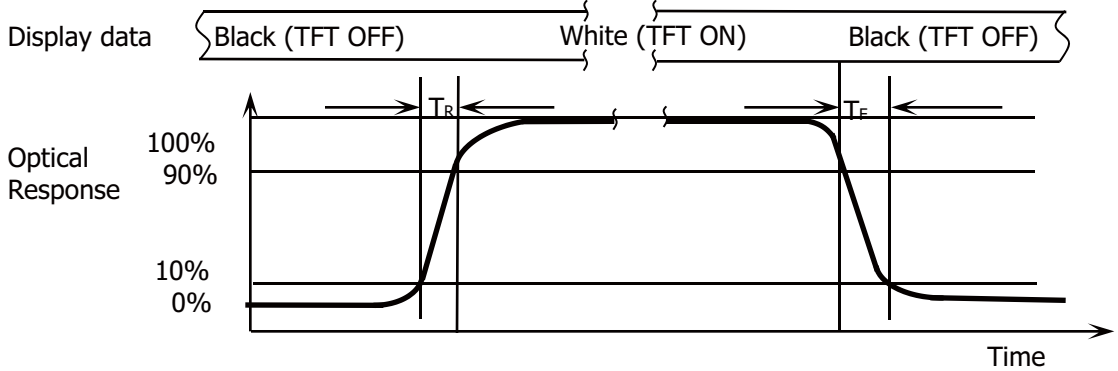

The electro-optical response time measurements shall be made as shown in FIG URE5 by switching the “data” input signal ON and OFF. The times needed for th e luminance to change from 10% to 90% is  $T_r$  and 90% to 10% is  $T_d$ .

## 9.0 MECHANICAL OUTLINE DIMENSION

Figure 6. TFT-LCD Module Outline Dimension (Front View)

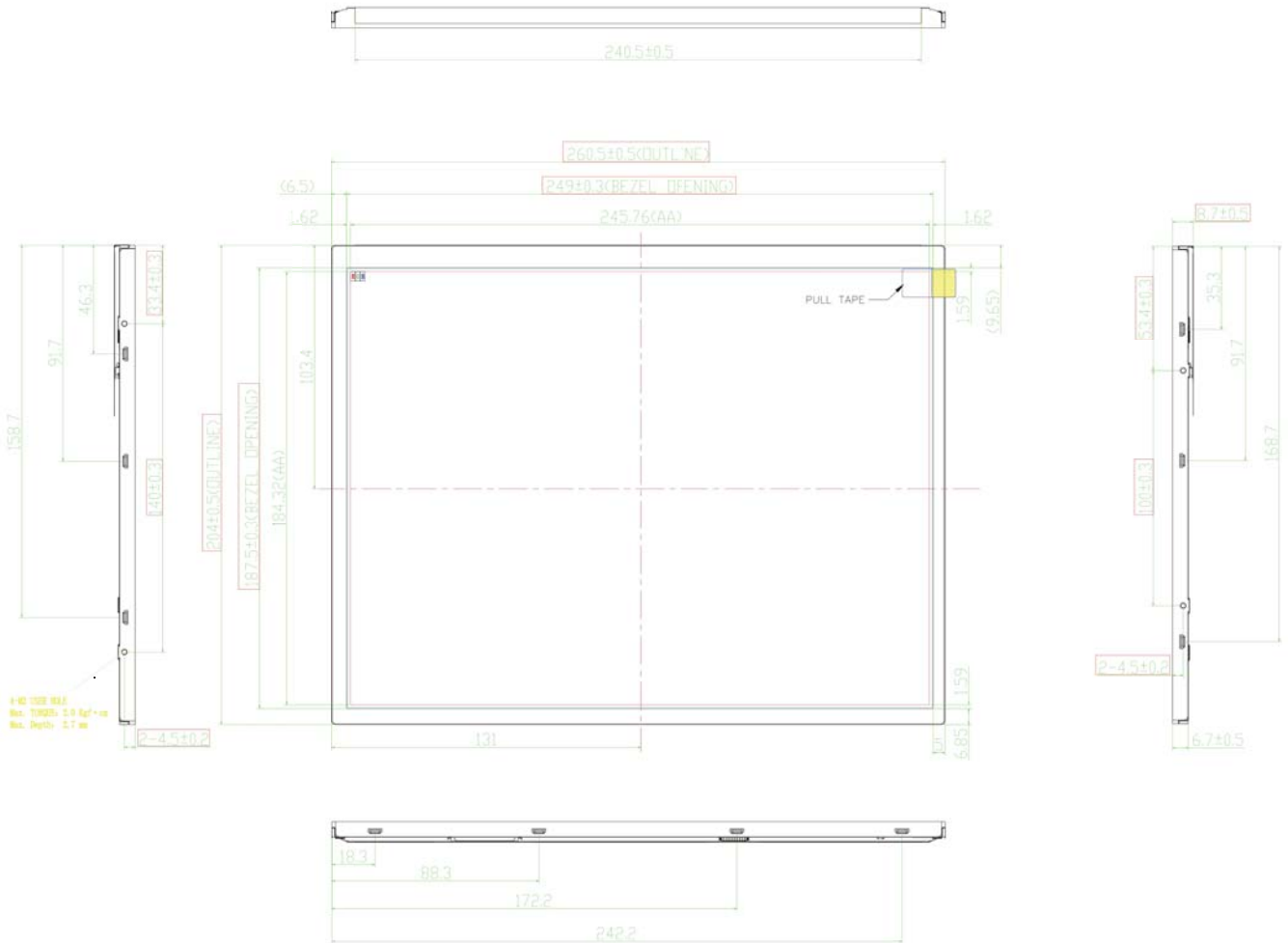
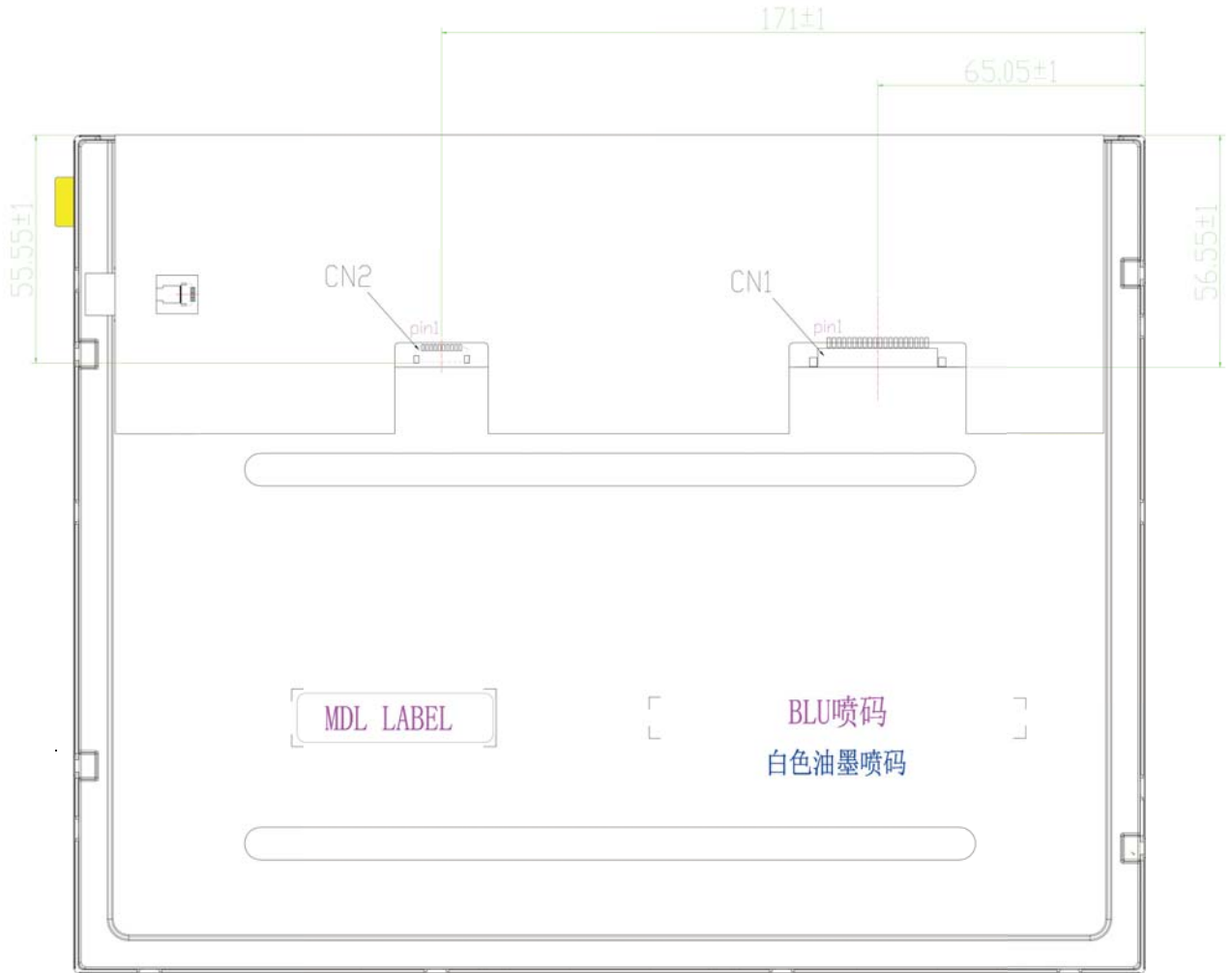

Figure 7. TFT-LCD Module Outline Dimensions (Rear view)



### 10.0 RELIABILITY TEST

The Reliability test items and its conditions are shown in below.

<Table 10. Reliability test>

No	Test Items	Conditions	Remark
1	High temperature storage test	Ta = 80°C, 240 hrs	
2	Low temperature storage test	Ta = -30 °C, 240 hrs	
3	High temperature operation test	Ta = 70°C, 240 hrs	
4	Low temperature operation test	Ta = -20 °C, 240 hrs	
5	High temperature & high humidity operation test	Ta = 60 °C, 90%RH, 240 hrs	
6	Thermal shock	Ta = -40 °C (0.5 hr)↔ 80°C (0.5 hr), 100 cycle	Non-operation
7	Image Sticking	Burn in:5*5 Chess,1h@25C. Inspection Pattern:50% grey, Perpendicular view, after 3mins,the mura must disappear	
8	ESD test	Air Voltage:±15KV Contact Voltage:±8KV Class B	
9	Vibration Test	1.47G, Random, X/Y per 30min, Z per 60min	

Note : After the reliability test, the product only guarantee function normally without any fatal defect (non-display, line defect, abnormal display etc ). All the cosmetic specification is judged before the reliability test.

## • 11.0 Precautions

Please pay attention to the followings when you use this TFT LCD Panel.

### • 11.1 Mounting Precautions

- (1) Use fingerstalls with soft gloves in order to keep display clean during the incoming inspection and assembly process.
- (2) You must mount a module using specified mounting holes (Details refer to the drawings).
- (3) Please make sure to avoid external forces applied to the Source PCB and D-IC during the process of handling or assembling. If not, It causes panel damage or malfunction.
- (4) Note that polarizers are very fragile and could be easily damaged. Do not touch, push or rub the exposed polarizers with glass, tweezers or anything harder than HB pencil lead. And please do not rub with dust clothes with chemical treatment.
- (5) Do not pull or fold the source D-IC which connect the source PCB and the panel.
- Do not pull or fold the LED wire.
- (6) After removing the protective film, when the surface becomes dusty, please wipe gently with absorbent cotton or other soft materials like chamois soaks with alcohol or purified water.
- Do not strong polar solvent because they cause chemical damage to the polarizer.
- (7) Wipe off saliva or water drops as soon as possible. Their long time contact with polarizer causes deformations and color fading.
- (8) Protection film for polarizer on the module shall be slowly peeled off just before use so that the electrostatic charge can be minimized.
- (9) Since the LCD is made of glass, do not apply strong mechanical impact or static load onto it. Handling with care since shock, vibration, and careless handling may seriously affect the product. If it falls from a high place or receives a strong shock, the glass may be broken.
- (10) Do not disassemble the module.
- (11) To determine the optimum mounting angle, refer to the viewing angle range in the specification for each model.
- (12) If the customer's set presses the main parts of the LCD, the LCD may show the abnormal display. But this phenomenon does not mean the malfunction of the LCD and should be pressed by the way of mutual agreement.
- (13) Do not drop water or any chemicals onto the LCD's surface.

## 11.2 Operating Precautions

- (1) Be careful for condensation at sudden temperature change. Condensation makes damage to polarizer or electrical contacted parts. And after fading condensation, smear or spot will occur.
- (2) Module has high frequency circuits. Sufficient suppression to the electromagnetic interference shall be done by system manufacturers. Grounding and shielding methods may be important to minimized the interference.
- (3) The electrochemical reaction caused by DC voltage will lead to LCD degradation, so DC drive should be avoided.
- (4) The LCD modules use C-MOS LSI drivers, so customers are recommended that any unused input terminal would be connected to Vdd or Vss, do not input any signals before power is turn on, and ground you body, work/assembly area, assembly equipments to protect against static electricity.
- (5) Do not exceed the absolute maximum rating value. (supply voltage variation, input voltage variation, variation in part contents and environmental temperature, and so on) Otherwise the Module may be damaged.
- (6) Design the length of cable to connect between the connector for back-light and the converter as short as possible and the shorter cable shall be connected directly.  
The longer cable between that of back-light and that of converter may cause the luminance of LED to lower and need a higher startup voltage(Vs).
- (7) Connectors are precise devices for connecting PCB and transmitting electrical signals. Operators should insert and unplug MDL in parallel when assembling MDL.
- (8) Do not connect or disconnect the cable to/ from the module at the "Power On" condition.
- (9) When the module is operating, do not lose CLK, ENAB signals. If any one these signals is lost, the LCD panel would be damaged.
- (10) Obey the supply voltage sequence. If wrong sequence is applied, the module would be damaged.
- (11) Do not re-adjust variable resistor or switch etc.

## 11.3 Electrostatic Discharge Control

- (1) Since a module is composed of electronic circuits, it is not strong to electrostatic discharge. Make certain that treatment persons are connected to ground through wrist band etc. And don't touch interface pin directly. Keep products as far away from static electricity as possible.
- (2) Avoid the use work clothing made of synthetic fibers. We recommend cotton clothing or other conductivity-treated fibers.

## 11.4 Precautions for Strong Light Exposure

It is not allowed to store or run directly in strong light or in high temperature and humidity for a long time; Strong light exposure causes degradation of polarizer and color filter.

## 11.5 Storage Precautions

When storing modules as spares for a long time, the following precautions are necessary.

- (1) The polarizer surface should not come in contact with any other object.  
It is recommended that they be stored in the container in which they were shipped.  
Temperature : 5 ~ 40 °C
- (2) Humidity : 35 ~ 75 %RH
- (3) Period : 12 months
- (4) Control of ventilation and temperature is necessary.
- (5) Please make sure to protect the product from strong light exposure, water or moisture.  
Be careful for condensation.
- (6) Store in a polyethylene bag with sealed so as not to enter fresh air outside in it.
- (7) Do not store the LCD near organic solvents or corrosive gasses.
- (8) Please keep the Modules at a circumstance shown below Fig.

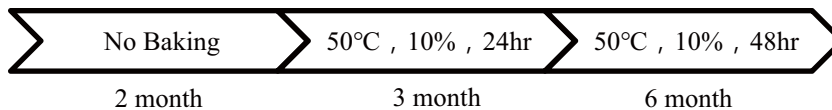

## 11.6 Precautions for Protection Film (适用通用产品, 含Q/Single Production)

- (1) Remove the protective film slowly, keeping the removing direction approximate 30-degree not vertical from panel surface, If possible, under ESD control device like ion blower, and the humidity of working room should be kept over 50%RH to reduce the risk of static charge.
- (2) In handling the LCD, wear non-charged material gloves. And the conducting wrist to the earth and the conducting shoes to the earth are necessary.

## 11.7 Appropriate Condition for Display

- (1) Normal operating condition
  - Temperature: 0 ~ 40°C
  - Operating Ambient Humidity : 10 ~ 90 %
  - Display pattern: dynamic pattern (Real display)
  - Suitable operating time: under 16 hours a day. ( Please contract AMSON in advance for 7\*24hrs or more than suggested Operating time )
  - Long-term lighting products recommended regular shutdown

- (2) Special operating condition

If the product will be used in extreme conditions such as high temperature, humidity, display patterns or 7\*24hrs operation time etc., It is strongly recommended to contact AMSON for Application engineering advice. Otherwise, its reliability and function may not be guaranteed.

- (3) Black image or moving image is strongly recommended as a screen save.



- (4) Lifetime in this spec. is guaranteed only when commercial display is used according to operating usages.
- (5) Please contact AMSON in advance for outdoor operation.
- (6) Please contact AMSON in advance when you display the same pattern for a long time.
- (7) If the Module keeps displaying the same pattern for a long period of time, the image may be "sticked" to the screen. To avoid image sticking, it is recommended to use a screen saver.
- (8) Do not exceed the absolute maximum rating value. (supply voltage variation, input voltage variation, variation in part contents and environmental temperature, and so on) Otherwise the Module may be damaged.
- (9) Dew drop atmosphere should be avoided.
- (10) The storage room should be equipped with a good ventilation facility and avoid to expose to corrosive gas , which has a temperature controlling system.
- (11) When expose to drastic fluctuation of temperature (hot to cold or cold to hot ) ,the LCD may be affected; Specifically, drastic temperature fluctuation from cold to hot ,produces dew on the LCD's surface which may affect the operation of the polarizer and the LCD.
- (12) Response time will be extremely delayed at lower temperature than the operating temperature range and on the other hand at higher temperature LCD may turn black at temperature above its operational range. However those phenomena do not mean malfunction or out of order with the LCD. The LCD will revert to normal operation once the temperature returns to the recommended temperature range for normal operation

## 11.8 Others

### A. LC Leak

- If the liquid crystal material leaks from the panel, it is recommended to wash the LC with acetone or ethanol and then burn it.
- In case of contact with hands, skin or clothes, it has to be washed away thoroughly with soap.
- If LC in mouth, mouth need to be washed, drink plenty of water to induce vomiting and follow medical advice.
- If LC touch eyes, eyes need to be washed with running water at least 15 minutes.

### B. Rework

- When returning the module for repair or etc., Please pack the module not to be broken. We recommend to use the original shipping packages.

## 12.0 LABEL

(1) Product label

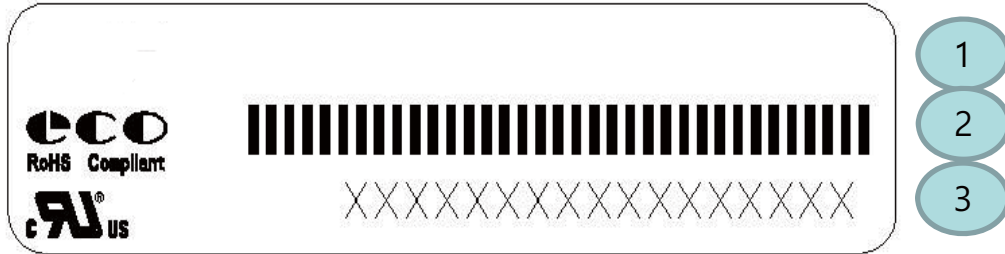

- Label Size :48mm\*12mm / Thickness: 0.08mm
- Contents
  1. FG-CODE: XXXXXXXXXXXX
  2. MDL ID Barcode
  3. MDL ID

MDL ID Naming Rule:

序列号	1	2	3	4	5	6	7	8	9	10	11	12	13	14	15	16	17
代码	X	X	X	3	X	X	X	3	8	5	0	X	X	X	X	X	X
描述	GBN代码		等级	B3	年份		月	FG Code后四位				序列号					

(3) Box label

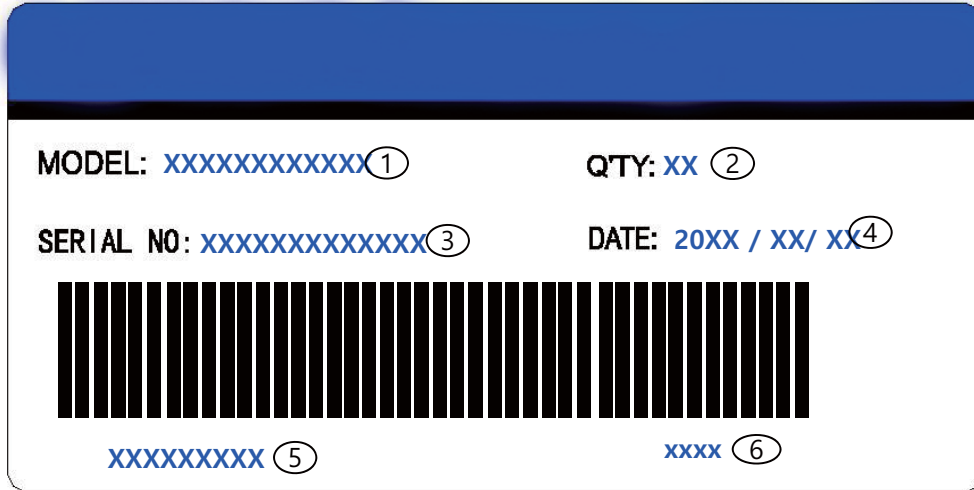

Serial number marked part needs to print, show as follows:

1. FG-CODE(Before 12 bit)
2. Product quantity
3. Box ID
4. Date
5. The client section material number(The client)
6. FG-Code After four

Total Size:100×50mm

No.	1	2	3	4	5	6	7	8	9	10	11	12	13
Code	X	X	S	3	1	8	B	0	0	0	1	H	D
	GBN		Grade	B3	Year	Month	Rev	Serial number					

### 13.0 PACKING INFORMATION

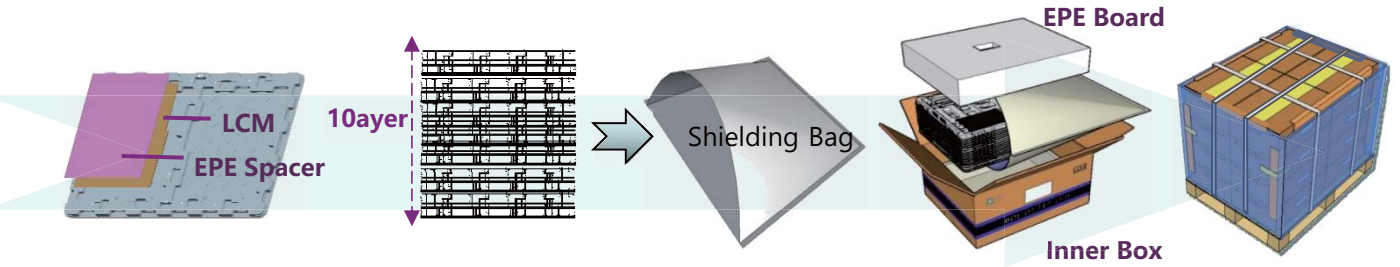

- 1-. Put the LCM in the Tray
  - Then put the Spacer on the LCM
  - Capacity: 2pcs LCM/Tray  
2pcs Spacer/Tray
- 2-. Repeat put the Tray & Panel & Spacer until to 9pcs,  
At last put 1pcs empty Tray
  - Put the 10pcs Tray in the Shielding Bag to vacuum
- 3-. Put one EPE Board in the Inner Box
  - Put the Shielding Bag with 10 pcs Tray  
in the EPE Board
  - At last put one EPE Board
  - Capacity : 18pcs LCM/Box
- 4-. Put 16EA Box on the Pallet
  - Secure with strapping tape, wrap around  
film, paper protection Angle.
  - Capacity: 4EA Box/Layer, 4Layer, 288pcs LCM/Pallet

**Note**

- Box dimension: :607mm(W) x 507mm(D) x 240mm(H)
- Package quantity in one box: 18pcs