



Specification for Approval

Customer: _____

Model Name: _____

Supplier Approval			Customer approval
R&D Designed	R&D Approved	QC Approved	
<i>Peter</i>	<i>Peng Jun</i>		

CONTENTS:

No.	Item	Page
1	BASIC SPECIFICATION	
	1.1 Mechanical Specification	4
	1.2 Display Specification	4
	1.3 Outline Dimension	5
	1.4 Block Diagram	6
	1.5 Interface Pin	7
2	ELECTRICAL CHARACTERISTICS	
	2.1 Absolute Maximum Ratings	8
	2.2 DC Characteristics	9
	2.3 Back-light Characteristics	10
	2.4 AC Characteristics	11~13
	2.5 Touch Panel Specifications	14~16
3	OPTICAL CHARACTERISTICS	
	3.1 Condition	17
	3.2 Definition of Optical Characteristics	18~19
4	RELIABILITY	20
5	PRODUCT HANDING AND APPLICATION	21
6	DATECODE	22
7	PACKING & LOTNO	23~24
8	INSPECTION STANDARD	25~30

1. BASIC SPECIFICATION

1.1 Mechanical specifications

Items	Nominal Dimension	Unit
Active screen size	5.7" diagonal	-
Dot Matrix	640 x RGB x 480	Pixel
Module Size (W x H x T)	127.0 x 98.43 x 10.06	mm.
Active Area (W x H)	115.2 x 86.4	mm.
Pixel Size (WxH)	0.18 x 0.18	mm.
Color depth	262K	color
Interface	Parallel 18-bit RGB	-
Driving IC Package	COG	-
Module weight	106	g

1.2 Display specification

Display	Descriptions	Note
LCD Type	a-Si TFT	-
LCD Mode	TN / Normal white	-
Polarizer Mode	Transmissive	-
Polarizer Surface	Normal	-
Pixel arrangement	RGB-stripe	-
Backlight Type	LED	-
Viewing Direction(Gray inversion)	6 O'clock	1

*Color tone is slightly changed by temperature and driving voltage.

Note 1 : The viewing direction defined in this specification is according to the rubbing direction of its TFT surface treatment by the TFT glass manufacturer. The grayscale inversion is at this direction as well. However, the optimal viewing direction for human view is normally where the color does NOT change to grayscale inversion, and this would be the opposite site of the specified viewing direction in this specification. In any case we advise customers to judge by themselves, and be aware of this phenomenon.

1.3 Outline dimension

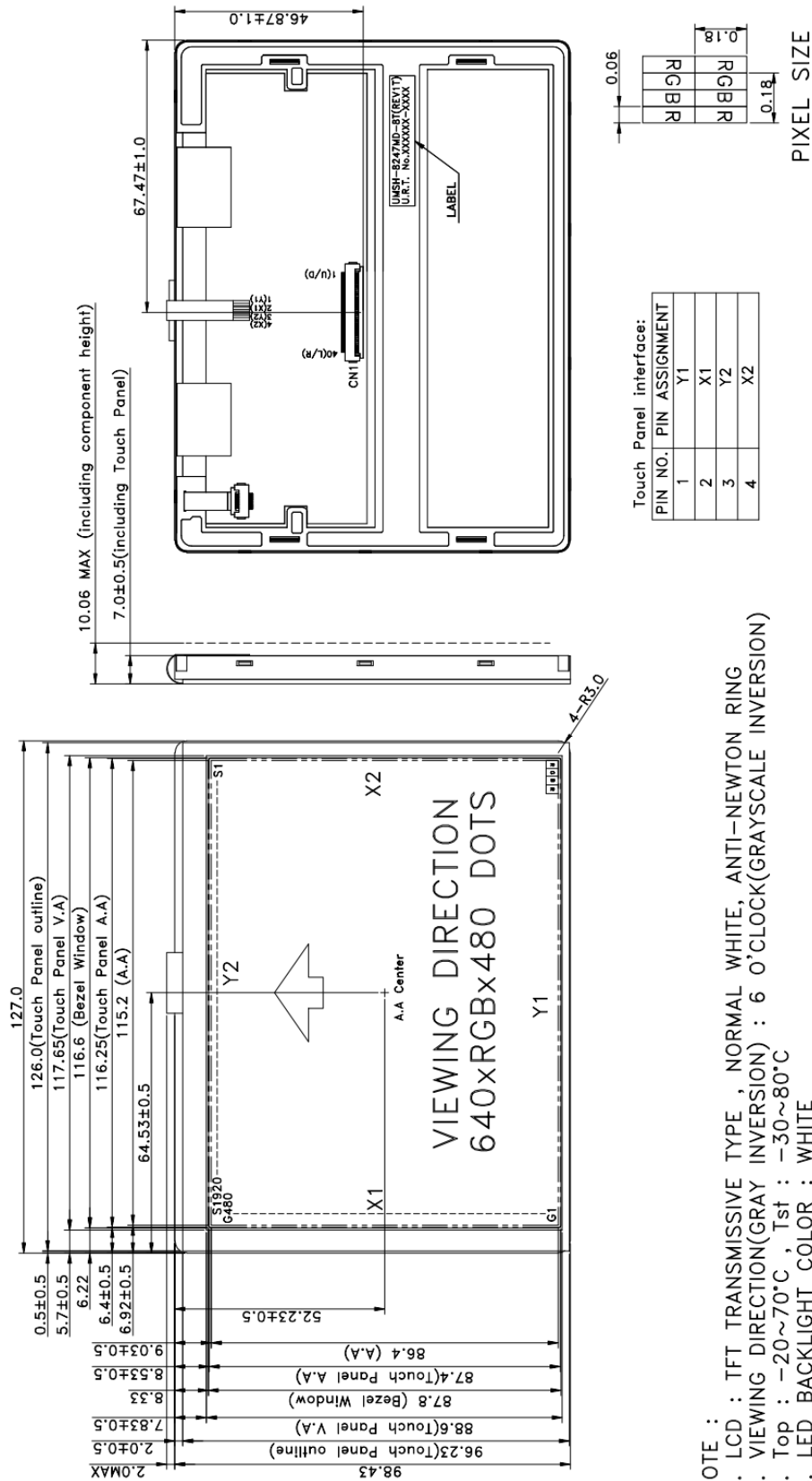

- NOTE :
1. LCD : TFT TRANSMISSIVE TYPE , NORMAL WHITE, ANTI-NEWTON RING
 2. VIEWING DIRECTION(GRAY INVERSION) : 6 O'CLOCK(GRAYSCALE INVERSION)
 3. Top : -20~70°C , Tst : -30~80°C
 4. LED BACKLIGHT COLOR : WHITE
 5. CONSTANT VOLTAGE FOR LED DRIVER : VLED=5.0 V, ILED=340.0mA(TYP.)
 6. BRIGHTNESS : 200 cd/m² (MIN), 250 cd/m² (TYP)
 7. TOLERANCE FOR NOT ASSIGNED : ±0.3mm
 8. RoHS-COMPLIANT
 9. CN1 : 6705-E40N-00R(E&T) OR COMPATIBLE CONNECTORS
 10. COMPONENT AREA CAN NOT BENDING.

1.4 Block diagram:

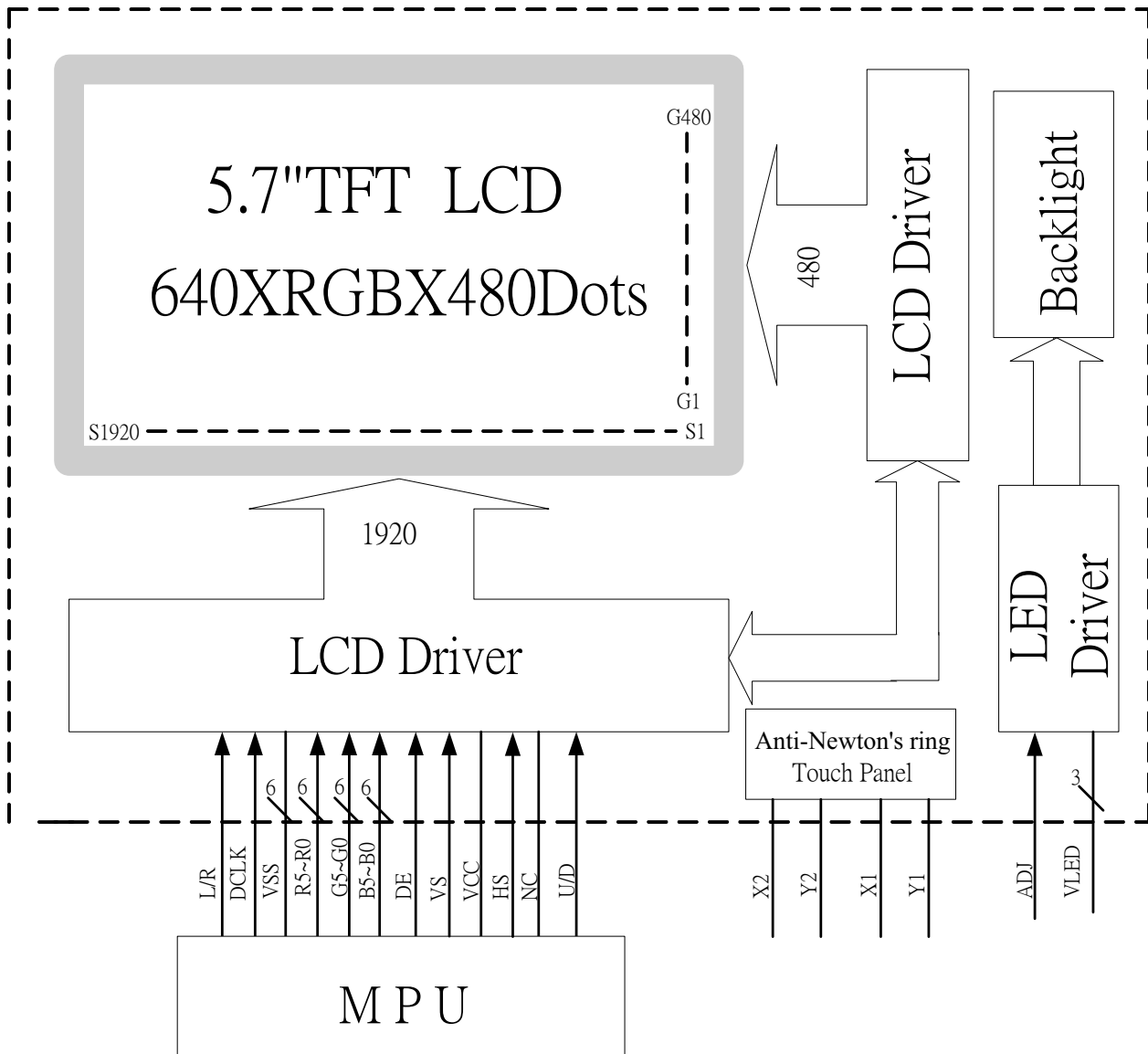

1.5 Interface pin connection:

Pin No.	Pin Symbol	I/O	Description
1	U/D	I	Up or Down Display Control
2	NC	-	Customer non-connect.
3	HS	I	Hsync Horizontal SYNC.
4~6	VLED	P	Power supply for digital circuit LED.(+5.0V)
7	VCC	P	Power supply for digital circuit LCD. (+3.3V)
8	VS	I	Vsync Vertical SYNC
9	DE	I	Data enable
10	X2	-	Touch Screen.
11	Y1	-	Touch Screen.
12	ADJ	I	Adjust for LED brightness(PWM), HIGH active(+5.0V)
13	B5	I	Blue data input (MSB)
14、15	B4、B3	I	Blue data input
16	VSS	P	Power ground
17、18	B2、B1	I	Blue data input
19	B0	I	Blue data input (LSB)
20	VSS	P	Power ground
21	G5	I	Green data input (MSB)
22、23	G4、G3	I	Green data input
24	VSS	P	Power ground
25、26	G2、G1	I	Green data input
27	G0	I	Green data input (LSB)
28	VSS	P	Power ground

Pin No.	Pin Symbol	I/O	Description
29	R5	I	Red data input (MSB)
30、31	R4、R3	I	Red data input
32	VSS	P	Power ground
33、34	R2、R1	I	Red data input
35	R0	I	Red data input (LSB)
36	X1	-	Touch Screen.
37	Y2	-	Touch Screen.
38	DCLK	I	Clock signals.
39	VSS	P	Power ground
40	L/R	I	Left or Right Display Control

2. ELECTRICAL CHARACTERISTICS

2.1 Absolute Maximum Ratings

Items	Symbol	Min.	Max.	Unit
Power supply voltage	VCC	-0.3	7.0	V
Input voltage	V _{in}	-0.3	VCC+0.3	V
LED supply voltage	VLED	--	6	V
Operate temperature range	T _{OP}	-20	70	°C
Storage temperature range	T _{ST}	-30	80	°C

2.2 DC Characteristics

$T_a = 25^\circ\text{C}$

Items	Symbol	Min.	Typ.	Max.	Unit	Condition
Supply voltage	V_{CC}	-	3.3	-	V	-
Input Voltage	V_{IL}	0	-	$0.3V_{CC}$	V	L level
	V_{IH}	$0.7V_{CC}$	-	V_{CC}	V	H level
Current consumption	I_{CC}	-	70	135	mA	Note 1

*Note1 :

Measuring Condition:

Standard Value MAX.

$T_a = 25^\circ\text{C}$

$V_{CC} - GND = 3.3V$

Display Pattern = Check pattern

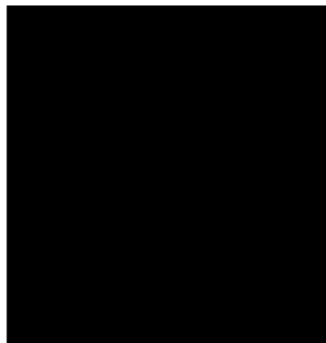

0 gray black pattern

2.3 Back-light Specification

PARAMETER	SYMBOL	MIN	TYP	MAX	Unit	Test Condition	NOTE
Supply Current	I_{LED}	-	340	510	mA	Ta=25°C V _{LED} =5V	-
Supply Voltage	V _{LED}	-	5	-	V	Ta=25°C	-
Half-Life Time	Lf	-	50000	-	hrs	Ta=25°C 60 RH%	1

Note 1 : The “ Half-Life Time ”is defined as the module brightness decrease to 50% original brightness.

2.4 AC Characteristics

2.4.1 AC Electrical Characteristics

PARAMETER	Symbol	Spec.			Unit
		Min.	Typ.	Max.	
HS setup time	T_{hst}	10	-	-	ns
HS hold time	T_{hhd}	10	-	-	ns
VS setup time	T_{vst}	10	-	-	ns
VS hold time	T_{vhd}	10	-	-	ns
Data setup time	T_{dsu}	10	-	-	ns
Data hold time	T_{dhd}	10	-	-	ns
DEN setup time	T_{esu}	10	-	-	ns
VS falling to HS falling time on odd field @ RGB mode	T_{HV_O}	-4	0	+4	T_{CPH}
VS falling to HS falling time on even field @ RGB mode	T_{HV_E}	0.4	0.5	0.6	T_H
Source output settling time	T_{ST}	-	12	20	μs
Source output loading R	R_{SL}	-	2	-	K ohm
Source output loading C	C_{SL}	-	60	-	pF
POL output delay time	T_{DP}	-	-	40	ns

2.4.2 Digital Parallel RGB interface (1920x480 resolution) :



PARAMETER	Symbol	Spec.			Unit
		Min.	Typ.	Max.	
CLK frequency	F_{CPH}	-	25.175	-	MHz
CLK period	T_{CPH}	-	39.7	-	ns
CLK pulse duty	T_{CWH}	40	50	60	%
HS period	T_H	-	800	-	T_{CPH}
HS pulse width	T_{WH}	5	30	-	T_{CPH}
HS-first horizontal data time	T_{HS}	112	144	175	T_{CPH}
DEN pulse width	T_{EP}	-	640	-	T_{CPH}
VS pulse width	T_{WV}	1	3	5	T_H
VS-DEN time	T_{STV}	-	35	-	T_H
VS period	T_V	-	525	-	T_H

Note: When SYNC mode is used. 1st data start from 144th CLK after HS falling (when $STHD[5:0]=00000$)

PARAMETER	Symbol	Spec.			Unit
		Min.	Typ.	Max.	
OEV pulse width	T_{OEV}	-	100	-	T_{CPH}
CKV pulse width	T_{CKV}	-	96	-	T_{CPH}
HS-CKV time	T_1	-	52	-	T_{CPH}
HS-OEV time	T_2	-	8	-	T_{CPH}
HS-POL time	T_3	-	72	-	T_{CPH}
STV setup time	T_{SUV}	-	46	-	T_{CPH}
STV pulse width	T_{WSTV}	-	1	-	T_H

2.4.3 Hardware reset timing

PARAMETER	Symbol	Spec.			Unit
		Min.	Typ.	Max.	
RESETB low pulse width	T_{rstw}	10	-	-	μs
Negative noise pulse width	T_{nr}		-	2	μs
Reset start time	T_{st}	2	-		μs

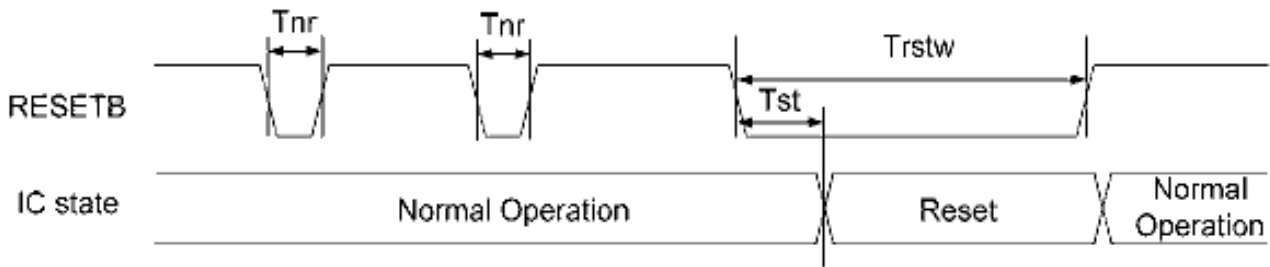

2.4.4 Interface Timing Chart

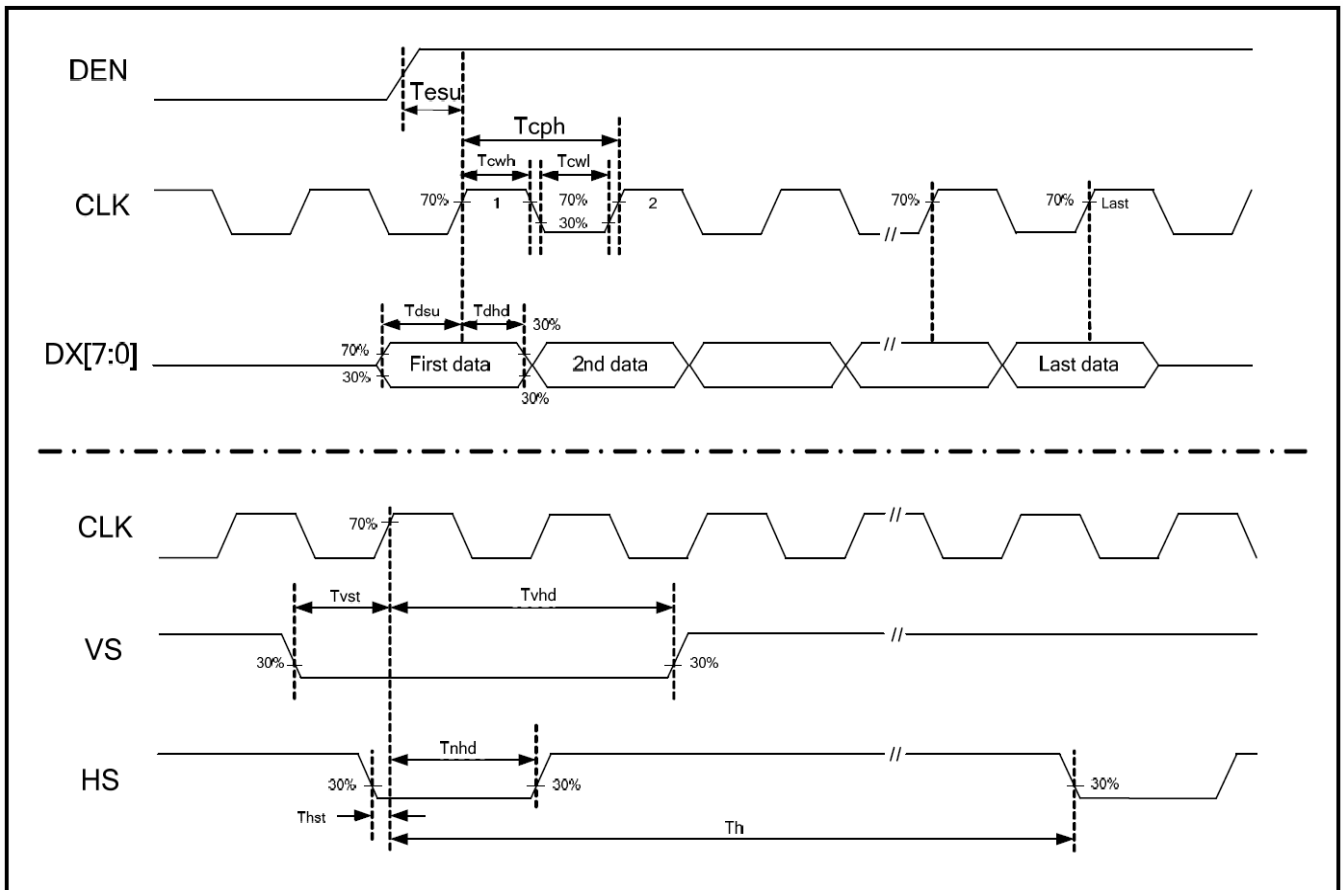

2.4.5 Data input format for RGB Mode

Parallel RGB SYNC Mode Horizontal Data Format :

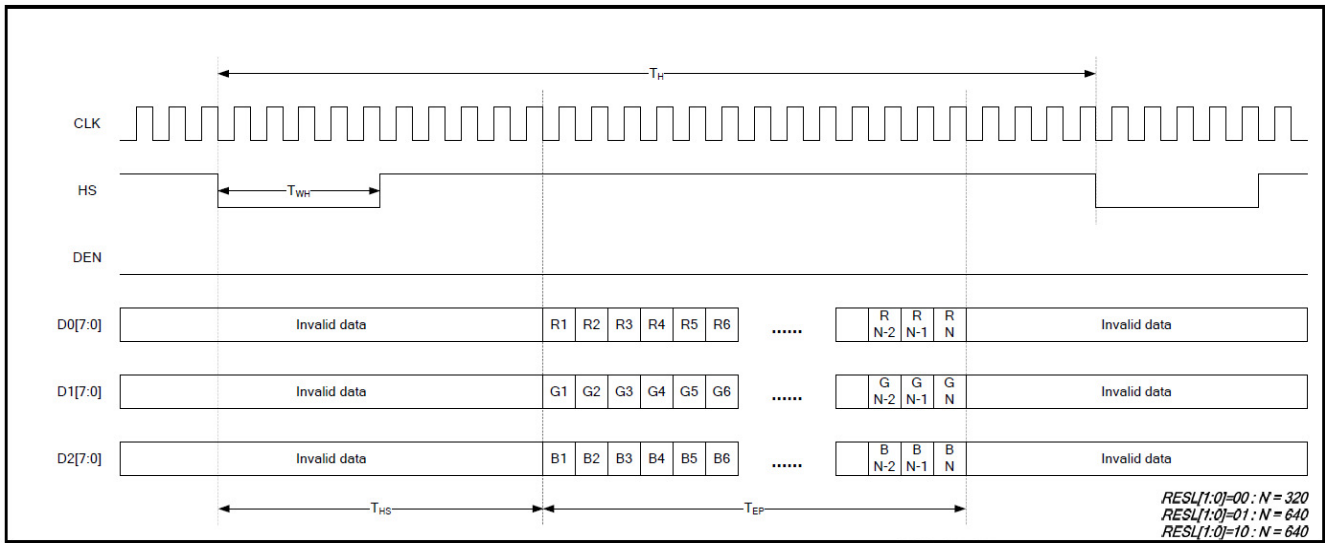

Parallel RGB DE Mode Horizontal Data Format :

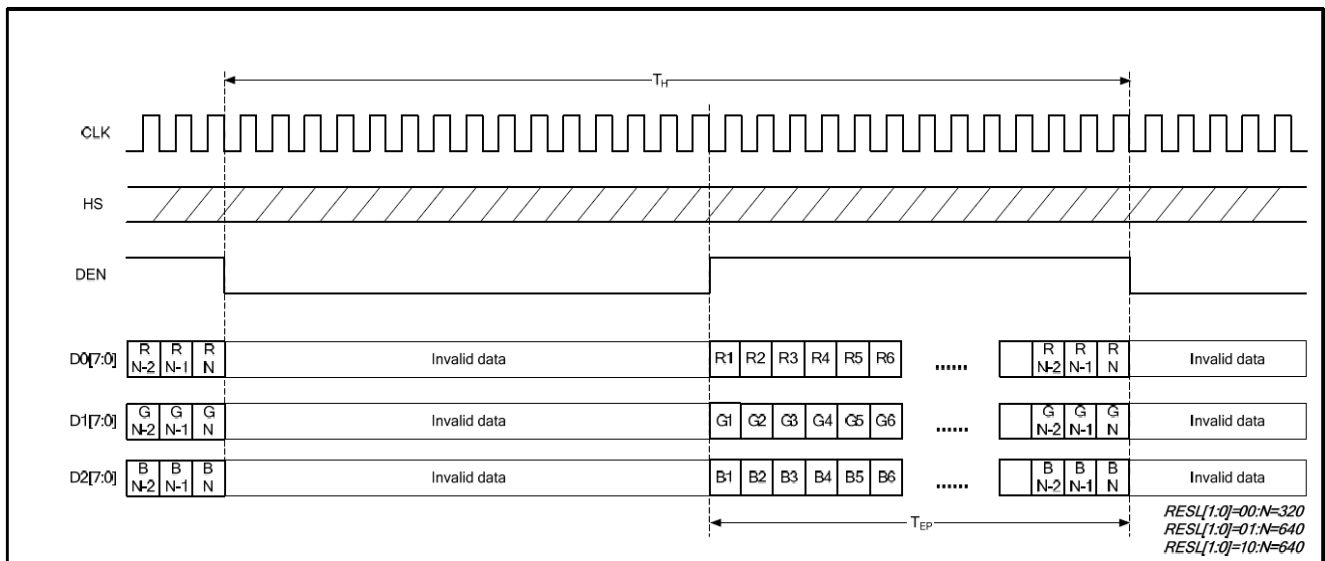

2.5 Touch Panel Specifications

Display	Descriptions	Note
Type	4-wires Analog Resistive Touch Panel	-
Structure	ITO Film : T=0.188mm	-
	ITO Glass : T=0.7mm	-
Surface Hardness	$\geq 3H$	3H pencil, pressure 500g/45° (JIS-K5600)
Input mode	Stylus or Finger	-
Operating Force (Minimum Active Force)	≤ 100 gf	Stylus R0.8mm (Active Area toward inner 2mm)
Connector Type	FPC	-

2.5.1 Electric Characteristics

Items	Descriptions	Note
Linearity	X-axis $\leq 1.5\%$	Active Area toward inner 2mm
	Y-axis $\leq 1.5\%$	
Terminal Resistance	X-axis : 350~950 Ω	-
	Y-axis : 100~700 Ω	-

2.5.2 Durability Test

Items	Condition
Finger Touch Test	Repeating impact the surface of touch panel 1,000k times by R8.0 silicon rubber under 250g loading and 2 times/sec speed.
Pen Sliding Test	Drawing line in 30mm length at same location of touch panel surface 100k times by R0.8mm plastic stylus under 250g loading and 60mm/sec moving speed.

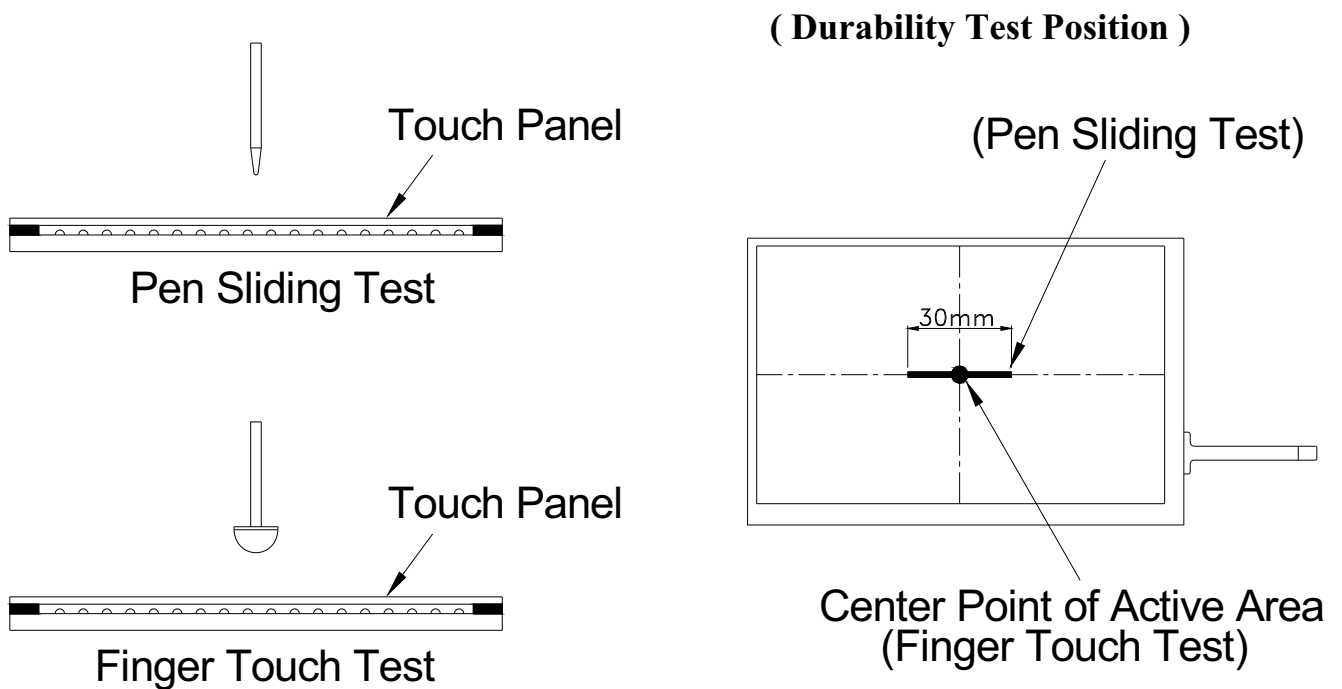

2.5.3. Attention for Assembly and Operation

Touch Panel as illustrated in the followings:

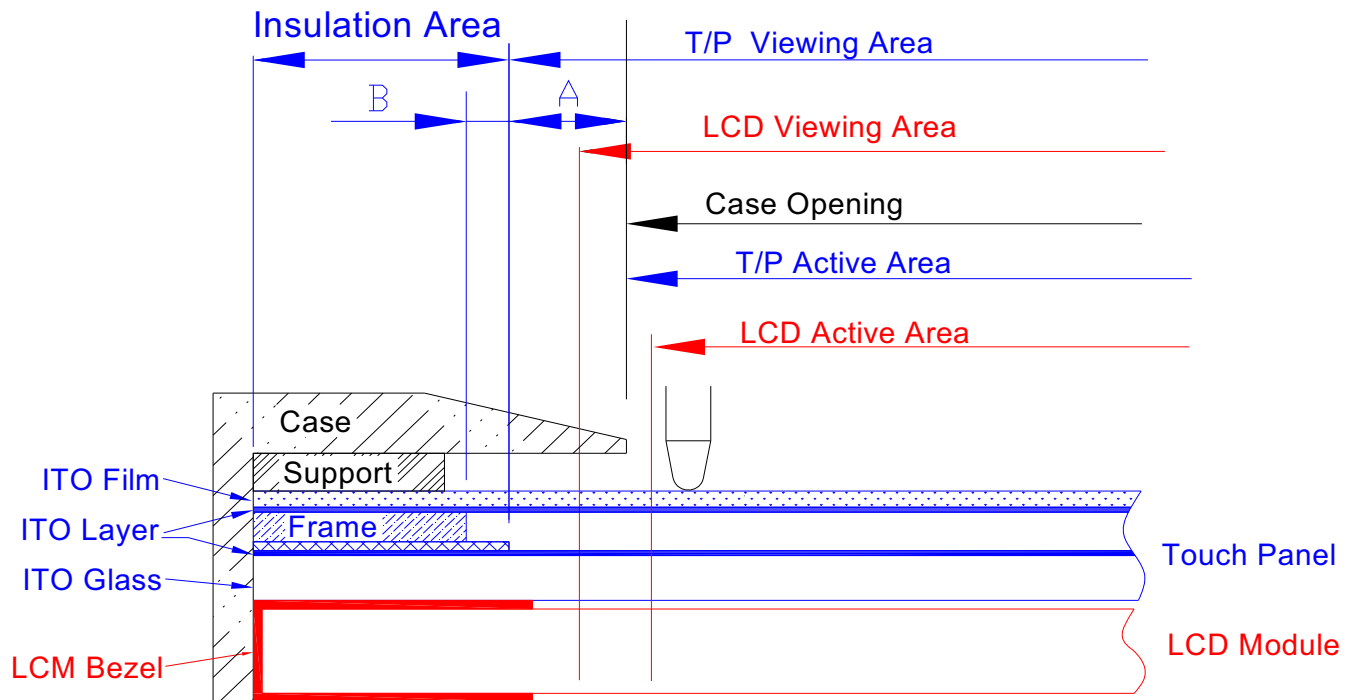

- (1) T/P Active Area : Means T/P guaranteed active area , where the feature and function of the T/P can be assured.
- (2) Area A : Where the T/P can be operated but the feature and function are not guaranteed.
- (3) Area B : This area is prohibited to contact , it is easy to hurt the ITO film and lose function once be touched .
- (4) a.Customer should design the "Support " in between the case and T/P ,with sufficient thickness to ensure once the case was deformed or pressed unintendedly , the T/P can still work normally .
 b.Support need to be designed within the frame size.
 c.We suggest to the support thickness as 0.5mm , but customer should adapt suitable thickness according to the case deformation.
- (5) The best design of customer's case opening is suggested to cover the LCD Viewing area and aligned with the T/P Active Area , or in between the dimension of LCD Viewing area and T/P Active Area . But once if the LCD Viewing area was smaller than T/P Active Area , then the case opening should be aligned with LCD Viewing area .
- (6) Never use double sided tape or glue in between the support and the ITO film , it will cause harm to ITO film or separate the T/P with the ITO film.

3. OPTICAL CHARACTERISTICS

3.1 Characteristics

Electrical and Optical Characteristics

No.	Item	symbol / temp.		Min.	Typ.	Max.	Unit	Note		
1	Response Time	Tr	25 °C	-	15	-	ms	2		
		Tf	25 °C	-	35	-				
2	Viewing Angle	Hor.	Cr ≥ 10	θ ₂₊	Φ=0°	60	75	-	degree	3
				θ ₂₋	Φ=180°	60	75	-		
		Ver.		θ ₁₊	Φ=270°	45	60	-		
				θ ₁₋	Φ=90°	60	75	-		
3	Contrast Ratio	Cr	25 °C	500	600	-	-	4		
4	Red x-code	Rx	25 °C	0.57	0.62	0.67	-	5		
	Red y-code	Ry		0.31	0.36	0.41				
	Green x-code	Gx		0.31	0.36	0.41				
	Green y-code	Gy		0.51	0.56	0.61				
	Blue x-code	Bx		0.10	0.15	0.20				
	Blue y-code	By		0.09	0.14	0.19				
	White x-code	Wx		0.29	0.34	0.39				
	White y-code	Wy		0.32	0.37	0.42				
	Brightness	Y		200	250	-	cd/m ²			
5	Brightness Uniformity		25 °C	85	-	-	%	6		

3.2 Definition of optical characteristics

Measurement condition :

Transmissive and Transflective type

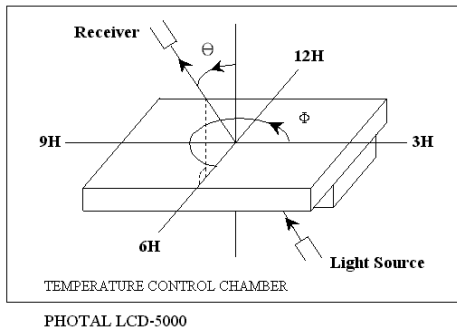

[Note 1] Definition of LCD Driving Vop and Waveform :

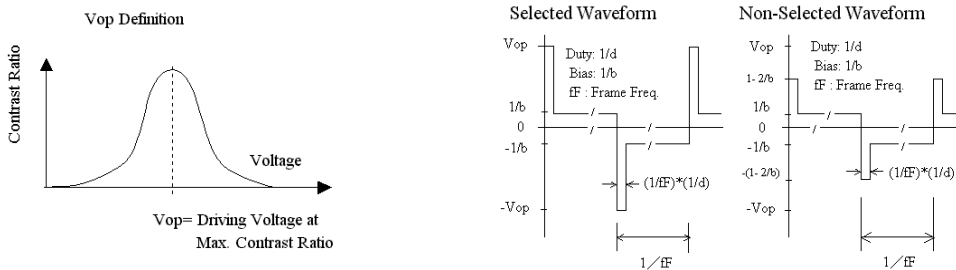

[Note 2] Definition of Response Time

for Positive type :

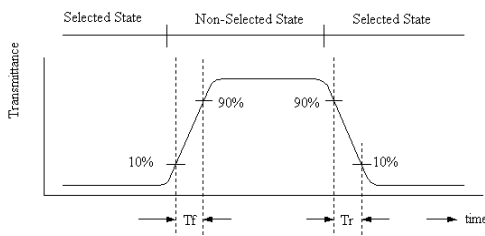

[Note 3] Definition of Viewing Angle :

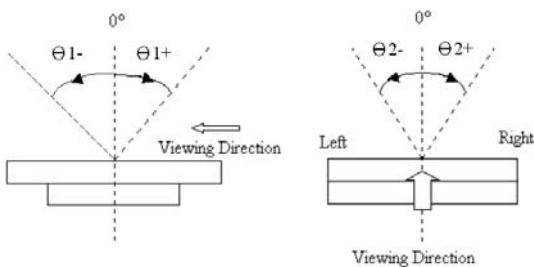

[Note 4] Definition of Contrast Ratio :

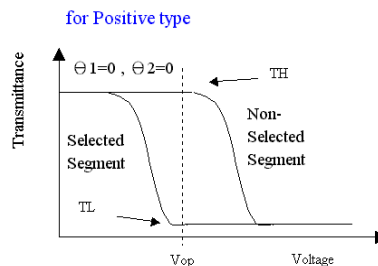

$$\text{Contrast Ratio} = \frac{TH}{TL}$$

[Note 5] Definition of measurement of Color Chromaticity and Brightness

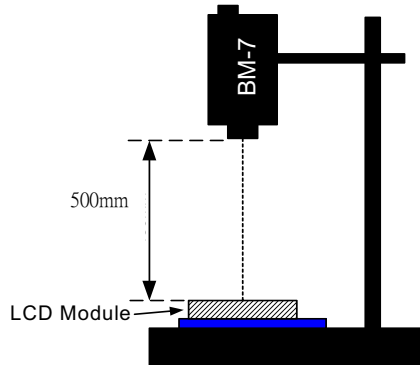

[Note 6] Definition of Brightness Uniformity

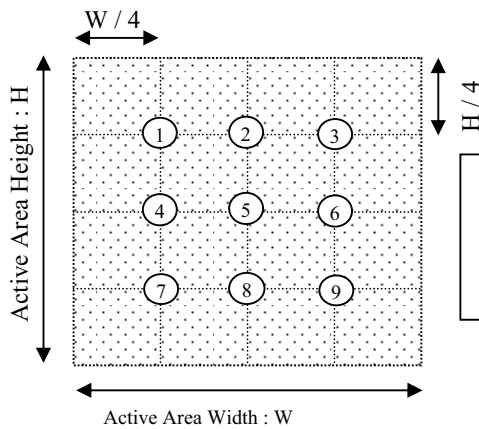

$$\text{Brightness Uniformity} = \frac{\text{Minimum Brightness of Point 1~9}}{\text{Maximum Brightness of Point 1~9}}$$

[Note 7] Definition of Measurement of Reflectance

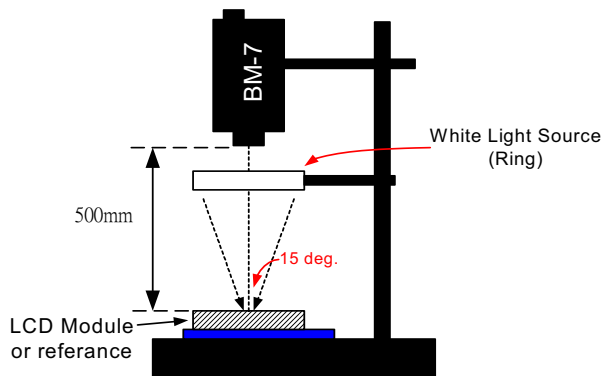

4. RELIABILITY :

Item No	Items	Condition	Note
1	High temperature operating	70 °C , 200 hours	1
2	Low temperature operating	-20 °C , 200 hours	1
3	High temperature storage	80 °C , 200 hours	1
4	Low temperature storage	-30 °C , 200 hours	1
5	High temperature & humidity storage	60°C, 90%RH, 100 hours	2
6	Thermal Shock storage	-30°C, 30min.<=> 80°C, 30min. 10 Cycles	1
7	Vibration test	10 => 55 =>10 => 55 => 10 Hz , within 1 minute Amplitude : 1.5mm. 15 minutes for each Direction (X,Y,Z)	
8	Drop test	Packed, 100CM free fall, 6 sides, 1 corner, 3edges	
9	Life time	50,000 hours 25°C , 60%RH, specification condition driving	

Note 1 : The product move into the room temperature for at least 2 hours with no condensation.

Note 2 : The product move into the room temperature for at least 24 hours with no condensation.

Note 3 : Please change the display picture (autorun) during operating mode. Avoid displaying static images to avoid image sticking , and the image sticking is accelerated by temperature.

* One single product test for only one item.

* Judgment after test : keep in room temperature for more than 2 hours.

- Current consumption < 2 times of initial value

- Contrast > 1/2 initial value

- Function : work normally

5. PRODUCT HANDLING AND APPLICATION

PRECAUTION FOR HANDLING LCM

- The LCD module contains a C-MOS LSI. People who operate the LCM should wear ESD protection equipment to prevent ESD hurt on products.
- Do not input any signal before power is turned on.
- Do not take LCM from its packaging bag until it is assembled.
- Peel off the LCM protective film slowly since static electricity may be generated.
- Pay attention to the humidity of the work shop, 50~60%RH is satisfactory.
- Use a non-leak iron for soldering LCM.
- Do not touch the display surface or connection terminals area with bare hands. Smudges on the display surface reduce the insulation between terminals.
- Cautions for soldering to LCM:
Condition for soldering I/O terminals:
Temperature at iron tip :350°C±15°C.
Soldering time : 3~4sec./ terminals.
Type of solder : Eutectic solder(rosin flux filled).

PRECAUTION IN USE OF LCD

- Do not contact or scratch the front surface and the contact pads of a LCD panel with hard materials such as metal or glass or with one's nail.
- To clean the surface , wipe it gently with soft cloth dampened by alcohol.
- Do not attempt to wiped off the contact pads.
- Keep LCD panels away from direct sunlight , also avoid them in high-temperature & high humidity environment for a long period.
- Do not drive LCD panels by DC voltage.
- Do not expose LCD panels to organic solvent.
- Liquid in LCD is hazardous substance. In case a contact with liquid crystal material is occurred, be sure to immediately wash such material away by soap and water.
- The polarizer is easily damaged and should be handle with special care. Don't press or rub it with hard objects.

PRECAUTION FOR STORING AND USE OF LCM

- To avoid degradation of the device , do not store the module under the conditions of direct sunlight , high temperature or high humidity . Keep the module in bags designed to prevent static electricity charging under low temperature / normal humidity conditions(avoid high temperature / high humidity and low temperature below 0°C)
- Never use the LCD , LCM under 45 Hz , the liquid crystal will decomposition and cause permently damage on display !!

USING ON MEDICAL CARE , SAFETY OR HAZARDOUS APPLICATION OR SYSTEM

- For the application in medical care, safety and hazardous products or systems, an authorization from AMSOM is required. AMSOM will not responsible for any damage or loss which caused by the products without any authorization given by AMSOM.
- This product is not allowed to be designed and used for military application and/or purpose.
- The delivery of this product to the countries and/or regions where the embargoes are imposed by U.N. is prohibited.
- The application and delivery of this product must comply with Strategic High-Tech Commodities (SHTC) export control and the sales to the embargoed and/or sanctioned countries or regions are strictly prohibited.

6. DATE CODE OF PRODUCTS

- Date code will be shown on each product :

- **YY MM DD - XXXX**

| | | |
Year Month Day - Serial no.

- Example: 121108 - 0003 ==> Year 2012, November,8th , Serial no.0003

Note : The lot no. attached on the packing box will be used for tracking once the part is too small to print the date code.

MODEL NO: UMSH-8247MD-8T(REV1T)

NOTE:

15 PCS/INDEX BOX

4 INDEX BOX/STACK

60 PCS/CARTON Kg/carton (gross weight)

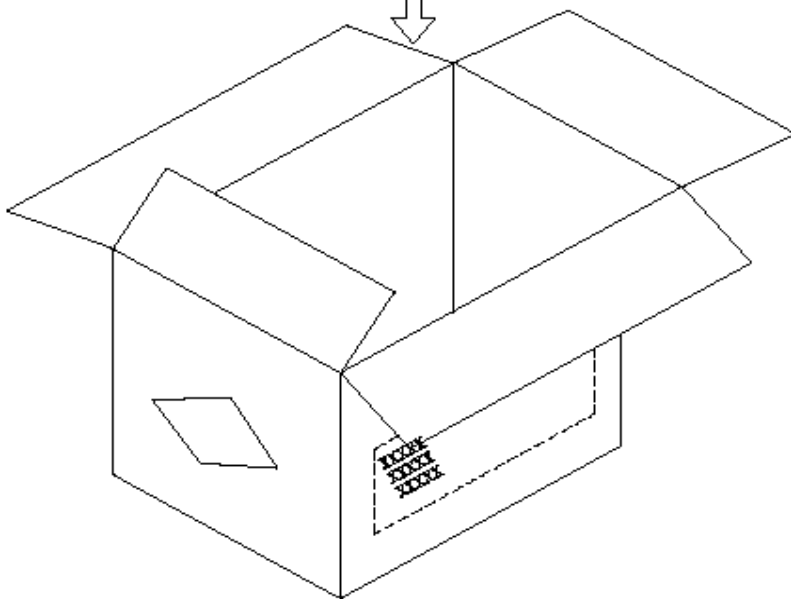
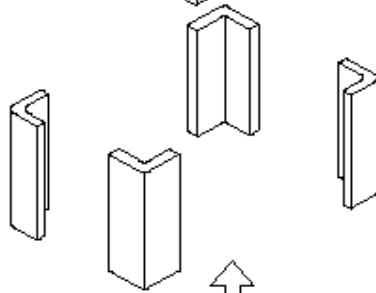
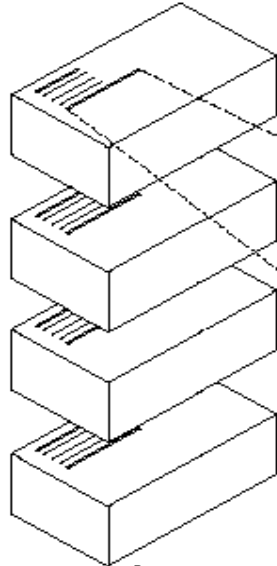

Model	No.
Q'ty	pcs
*	
Lot	No.
Q.C.	

8. INSPECTION STANDARD

8.1. QUALITY :

THE QUALITY OF GOODS SUPPLIED TO PURCHASER SHALL COME UP TO THE FOLLOWING STANDARD.

8.1.1. THE METHOD OF PRESERVING GOODS

AFTER DELIVERY OF GOODS FROM U.R.T. TO PURCHASER. PURCHASER SHALL CONTROL THE LCM AT -10 °C TO 40 °C ,AND IT MIGHT BE DESIRABLE TO KEEP AT THE NORMAL ROOM TEMPERATURE AND HUMIDITY UNTIL INCOMING INSPECTION OR THROWING INTO PROCESS LINE.

8.1.2. INCOMING INSPECTION

(A) THE METHOD OF INSPECTION

IF PURCHASER MAKE AN INCOMING INSPECTION , A SAMPLING PLAN SHALL BE APPLIED ON THE CONDITION THAT QUALITY OF ONE DELIVERY SHALL BE REGARDED AS ONE LOT.

(B) THE STANDARD OF QUALITY

ISO-2859-1 (SAME AS MIL-STD-105E) , LEVEL II SINGLE PLAN.

CLASS	AQL(%)
CRITICAL	0.4 %
MAJOR	0.65 %
MINOR	1.5 %
TOTAL	1.5 %

EVERY ITEM SHALL BE INSPECTED ACCORDING TO THE CLASS.

(C) MEASURE

IF AS THE RESULT OF ABOVE RECEIVING INSPECTION , A LOT OUT IS DISCOVERED.

PURCHASER SHALL BE INFORM SELLER OF IT WITHIN SEVEN DAYS. BUT FIRST SHIPMENT WITHIN FOURTEEN DAYS.

8.1.3. WARRANTY POLICY

U.R.T. WILL PROVIDE ONE-YEAR WARRANTY FOR THE PRODUCTS ONLY IF UNDER SPECIFICATION OPERATING CONDITIONS. U.R.T. WILL REPLACE NEW PRODUCTS FOR THESE DEFECT PRODUCTS WHICH UNDER WARRANTY PERIOD AND BELONG TO THE RESPONSIBILITY OF U.R.T.

8.2. CHECKING CONDITION

8.2.1. CHECKING DIRECTION SHALL BE IN THE 45 DEGREE AREA TO FACE THE SAMPLE.

8.2.2. CHECKER SHALL SEE OVER 300±25 mm. WITH BARE EYES FAR FROM SAMPLE AND USING 2 PCS. OF 20W FLUORESCENT LAMP.

8.3. INSPECTION PLAN :

CLASS	ITEM	JUDGEMENT	CLASS
PACKING & INDICATE	1. OUTSIDE AND INSIDE PACKAGE	"MODEL NO." , "LOT NO." AND "QUANTITY" SHOULD INDICATE ON THE PACKAGE.	Minor
	2. MODEL MIXED AND QUANTITY	OTHER MODEL MIXED.....REJECTED QUANTITY SHORT OR OVER.....REJECTED	Critical
	3. PRODUCT INDICATION	"MODEL NO." SHOULD INDICATE ON THE PRODUCT	Major
ASSEMBLY	4. DIMENSION, LCD GLASS SCRATCH AND SCRIBE DEFECT.	ACCORDING TO SPECIFICATION OR DRAWING.	Major
APPEARANCE	5. VIEWING AREA	POLARIZER EDGE OR LCD'S SEALING LINE IS VISABLE IN THE VIEWING AREAREJECTED	Minor
	6. BLEMISH 、BLACK SPOT 、 WHITE SPOT IN THE LCD AND LCD GLASS CRACKS	ACCORDING TO STANDARD OF VISUAL INSPECTION (INSIDE VIEWING AREA)	Minor
	7. BLEMISH 、BLACK SPOT WHITE SPOT AND SCRATCH ON THE POLARIZER	ACCORDING TO STANDARD OF VISUAL INSPECTION (INSIDE VIEWING AREA)	Minor
	8. BUBBLE IN POLARIZER	ACCORDING TO STANDARD OF VISUAL INSPECTION (INSIDE VIEWING AREA)	Minor
	9. LCD'S RAINBOW COLOR	STRONG DEVIATION COLOR (OR NEWTON RING) OF LCD.....REJECTED. OR ACCORDING TO LIMITED SAMPLE (IF NEEDED, AND INSIDE VIEWING AREA)	Minor
ELECTRICAL	10. ELECTRICAL AND OPTICAL CHARACTERISTICS (CONTRAST 、VOP 、 CHROMATICITY ... ETC)	ACCORDING TO SPECIFICATION OR DRAWING . (INSIDE VIEWING AREA)	Critical
	11.MISSING LINE	MISSING DOT 、LINE 、 CHARACTERREJECTED	Critical
	12.SHORT CIRCUIT 、 WRONG PATTERN DISPLAY	NO DISPLAY 、WRONG PATTERN DISPLAY 、CURRENT CONSUMPTION OUT OF SPECIFICATION..... REJECTED	Critical
	13. DOT DEFECT (FOR COLOR AND TFT)	ACCORDING TO STANDARD OF VISUAL INSPECTION	Minor

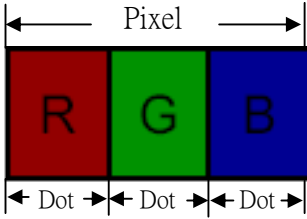

8.4. STANDARD OF VISUAL INSPECTION

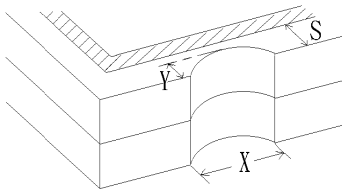
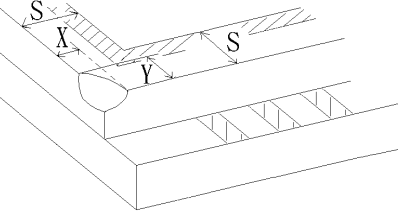
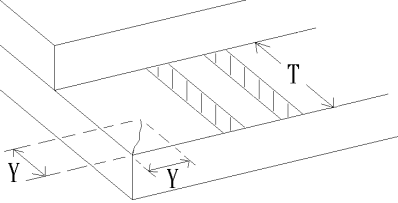
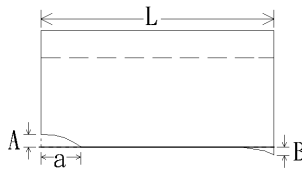
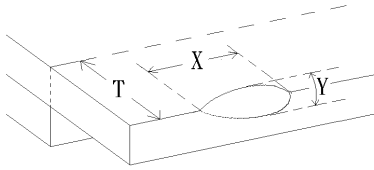
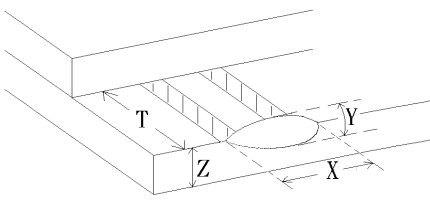
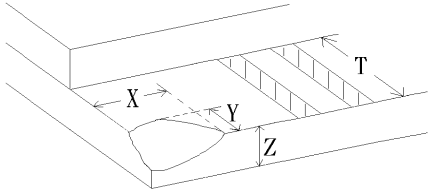
NO.	CLASS	ITEM	JUDGEMENT																				
8.4.1	MINOR	BLACK AND WHITE SPOT FOREIGN MATERIEL DUST IN THE CELL BLEMISH SCRATCH	<p>(A) ROUND TYPE: unit : mm.</p> <table border="1" style="width: 100%; border-collapse: collapse;"> <thead> <tr> <th style="width: 60%;">DIAMETER (mm.)</th> <th style="width: 40%;">ACCEPTABLE Q'TY</th> </tr> </thead> <tbody> <tr> <td style="text-align: center;">$\Phi \leq 0.1$</td> <td style="text-align: center;">DISREGARD</td> </tr> <tr> <td style="text-align: center;">$0.1 < \Phi \leq 0.25$</td> <td style="text-align: center;">3(Distance>5.0mm)</td> </tr> <tr> <td style="text-align: center;">$0.25 < \Phi$</td> <td style="text-align: center;">0</td> </tr> </tbody> </table> <p>NOTE: $\Phi = (\text{LENGTH} + \text{WIDTH}) / 2$</p> <p>(B) LINEAR TYPE: unit : mm.</p> <table border="1" style="width: 100%; border-collapse: collapse;"> <thead> <tr> <th style="width: 20%;">LENGTH</th> <th style="width: 30%;">WIDTH</th> <th style="width: 50%;">ACCEPTABLE Q'TY</th> </tr> </thead> <tbody> <tr> <td style="text-align: center;">-----</td> <td style="text-align: center;">$W \leq 0.03$</td> <td style="text-align: center;">DISREGARD</td> </tr> <tr> <td style="text-align: center;">$L \leq 5.0$</td> <td style="text-align: center;">$0.03 < W \leq 0.07$</td> <td style="text-align: center;">3(Distance>5.0mm)</td> </tr> <tr> <td style="text-align: center;">-----</td> <td style="text-align: center;">$0.07 < W$</td> <td style="text-align: center;">FOLLOW ROUND TYPE</td> </tr> </tbody> </table>	DIAMETER (mm.)	ACCEPTABLE Q'TY	$\Phi \leq 0.1$	DISREGARD	$0.1 < \Phi \leq 0.25$	3(Distance>5.0mm)	$0.25 < \Phi$	0	LENGTH	WIDTH	ACCEPTABLE Q'TY	-----	$W \leq 0.03$	DISREGARD	$L \leq 5.0$	$0.03 < W \leq 0.07$	3(Distance>5.0mm)	-----	$0.07 < W$	FOLLOW ROUND TYPE
DIAMETER (mm.)	ACCEPTABLE Q'TY																						
$\Phi \leq 0.1$	DISREGARD																						
$0.1 < \Phi \leq 0.25$	3(Distance>5.0mm)																						
$0.25 < \Phi$	0																						
LENGTH	WIDTH	ACCEPTABLE Q'TY																					
-----	$W \leq 0.03$	DISREGARD																					
$L \leq 5.0$	$0.03 < W \leq 0.07$	3(Distance>5.0mm)																					
-----	$0.07 < W$	FOLLOW ROUND TYPE																					
8.4.2	MINOR	BUBBLE IN POLARIZER DENT ON POLARIZER	<p style="text-align: right;">unit : mm.</p> <table border="1" style="width: 100%; border-collapse: collapse;"> <thead> <tr> <th style="width: 60%;">DIAMETER</th> <th style="width: 40%;">ACCEPTABLE Q'TY</th> </tr> </thead> <tbody> <tr> <td style="text-align: center;">$\Phi \leq 0.2$</td> <td style="text-align: center;">DISREGARD</td> </tr> <tr> <td style="text-align: center;">$0.2 < \Phi \leq 0.5$</td> <td style="text-align: center;">2(Distance>5.0mm)</td> </tr> <tr> <td style="text-align: center;">$0.5 < \Phi$</td> <td style="text-align: center;">0</td> </tr> </tbody> </table>	DIAMETER	ACCEPTABLE Q'TY	$\Phi \leq 0.2$	DISREGARD	$0.2 < \Phi \leq 0.5$	2(Distance>5.0mm)	$0.5 < \Phi$	0												
DIAMETER	ACCEPTABLE Q'TY																						
$\Phi \leq 0.2$	DISREGARD																						
$0.2 < \Phi \leq 0.5$	2(Distance>5.0mm)																						
$0.5 < \Phi$	0																						
8.4.3	MINOR	Dot Defect	<table border="1" style="width: 100%; border-collapse: collapse;"> <thead> <tr> <th style="width: 60%;">Items</th> <th style="width: 40%;">ACC. Q'TY</th> </tr> </thead> <tbody> <tr> <td>Bright dot</td> <td style="text-align: center;">$N \leq 4$ (Distance>5.0mm)</td> </tr> <tr> <td>Dark dot</td> <td style="text-align: center;">$N \leq 4$ (Distance>5.0mm)</td> </tr> </tbody> </table> <p>Pixel Define</p>  <p>Not 1: The definition of dot: The size of a defective dot over 1/2 of whole dot is regarded as one defective dot. Not 2: Bright dot: Dots appear bright and unchanged in size in which LCD panel is displaying under black pattern. Not 3: Dark dot: Dots appear dark and unchanged in size in which LCD panel is displaying under pure red, green, blue pattern.</p>	Items	ACC. Q'TY	Bright dot	$N \leq 4$ (Distance>5.0mm)	Dark dot	$N \leq 4$ (Distance>5.0mm)														
Items	ACC. Q'TY																						
Bright dot	$N \leq 4$ (Distance>5.0mm)																						
Dark dot	$N \leq 4$ (Distance>5.0mm)																						

NO.	CLASS	ITEM	JUDGEMENT
8.4.4	MINOR	LCD GLASS CHIPPING	 $Y > S$ Reject
8.4.5	MINOR	LCD GLASS CHIPPING	 $X \text{ or } Y > S$ Reject
8.4.6	MAJOR	LCD GLASS GLASS CRACK	 $Y > (1/2) T$ Reject
8.4.7	MAJOR	LCD GLASS SCRIBE DEFECT	 <ol style="list-style-type: none"> $a > L/3$, $A > 1.5\text{mm}$. Reject B : ACCORDING TO DIMENSION
8.4.8	MINOR	LCD GLASS CHIPPING (ON THE TERMINAL AREA)	 $\Phi = (x+y)/2 > 2.5 \text{ mm}$ Reject
8.4.9	MINOR	LCD GLASS CHIPPING (ON THE TERMINAL SURFACE)	 $Y > (1/3) T$ Reject
8.4.10	MINOR	LCD GLASS CHIPPING	 $Y > T$ Reject

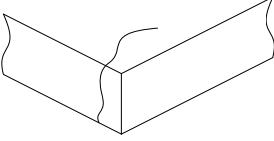
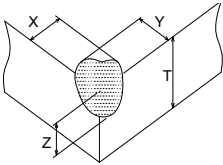
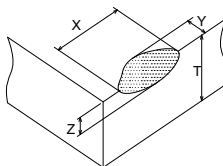
8.5 INSPECTION STANDARD OF TOUCH PANEL

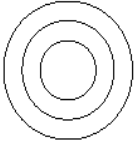
NO.	CLASS	ITEMS	JUDGEMENT						
8.5.1	MAJOR	Touch Panel Crack	 Reject						
8.5.2	MINOR	Touch Panel Chipping	<div style="display: flex; align-items: center;"> <div style="flex: 1;">  </div> <table border="1" style="font-size: small; border-collapse: collapse;"> <tr> <td style="width: 15%;">Not CNC Products</td> <td style="width: 55%;">X ≤ 2mm, Y ≤ 2mm, Z < 1/2T</td> <td style="width: 30%; text-align: center;">Accept</td> </tr> <tr> <td>CNC Products</td> <td>For CNC Outline Dimension</td> <td style="text-align: center;">Accept</td> </tr> </table> </div>	Not CNC Products	X ≤ 2mm, Y ≤ 2mm, Z < 1/2T	Accept	CNC Products	For CNC Outline Dimension	Accept
			Not CNC Products	X ≤ 2mm, Y ≤ 2mm, Z < 1/2T	Accept				
CNC Products	For CNC Outline Dimension	Accept							
<div style="display: flex; align-items: center;"> <div style="flex: 1;">  </div> <table border="1" style="font-size: small; border-collapse: collapse;"> <tr> <td style="width: 15%;">Not CNC Products</td> <td style="width: 55%;">X ≤ 3mm, Y ≤ 3mm, Z < 1/2T</td> <td style="width: 30%; text-align: center;">Accept</td> </tr> <tr> <td>CNC Products</td> <td>For CNC Outline Dimension</td> <td style="text-align: center;">Accept</td> </tr> </table> </div>	Not CNC Products	X ≤ 3mm, Y ≤ 3mm, Z < 1/2T	Accept	CNC Products	For CNC Outline Dimension	Accept			
Not CNC Products	X ≤ 3mm, Y ≤ 3mm, Z < 1/2T	Accept							
CNC Products	For CNC Outline Dimension	Accept							
8.5.3	MINOR	Scratch Dust and Foreign material (Linear Type)	$W \leq 0.05, L \leq 10\text{mm}$ Accept						
			$0.05\text{mm} < W \leq 0.07\text{mm} ; L \leq 5.0\text{mm}$ Accept 3 ea Max.						
			$W > 0.07\text{mm}$ Reject						
8.5.4	MINOR	Scratch Dust and Foreign material (Round Type : $\Phi = (\text{Length} + \text{Width}) / 2$)	$\Phi \leq 0.25\text{mm}$ Accept						
			$0.25\text{mm} < \Phi \leq 0.35\text{mm}$ Accept 5 ea Max.						
			$\Phi > 0.35\text{mm}$ Reject						
8.5.5	MINOR	Touch Panel Dent / Fish Eyes	$\Phi \leq 0.35\text{mm}$ Accept						
			$0.35\text{mm} < \Phi \leq 1.0\text{mm}$ Distance > 5.0mm Accept 3 ea Max.						
			$\Phi > 1.0\text{mm}$ Reject						
8.5.6	MINOR	Touch Panel Air Bubble	$\Phi \leq 0.2\text{mm}$ Accept						
			$0.2\text{mm} < \Phi \leq 0.5\text{mm}$ Accept 3 ea Max.						
			$\Phi > 0.5\text{mm}$ Reject						
8.5.7	MINOR	Touch Panel Printing area Scratch	$W \leq 0.03, L \leq 10\text{mm}$ Accept						
			$0.03\text{mm} < W \leq 0.05\text{mm}, L \leq 5\text{mm}$ Accept 3 ea Max.						
			$W > 0.05\text{mm}$ or $L > 5\text{mm}$ ($W > 0.05$ Follow 8.5.4 Round type) Reject						
8.5.8	MINOR	Touch Panel White Haze Mark / Dust	Can not be removed Reject						

NO.	CLASS	ITEMS	JUDEGMENT
8.5.10	MINOR	Inerratic Newton ring (For Resistive Touch Panel) 	1.Dimension of Newton ring > 1/3 V.A. area. Reject 2.Dimension of Newton ring < 1/3 V.A. area, not affect font effect and line distortion. Accept
		Atactic Newton ring (For Resistive Touch Panel) 	1.Dimension of Newton ring > 1/2 V.A. area. Reject 2.Dimension of Newton ring < 1/2 V.A. area, not affect font effect and line distortion. Accept
8.5.11	MINOR	Touch Panel Film Bulge	Not affect the transmittance and clarity under lighting ambient. Accept