



# Specification for Approval

Customer: \_\_\_\_\_

Model Name: \_\_\_\_\_

Supplier Approval			Customer approval
R&D Designed	R&D Approved	QC Approved	
<i>Peter</i>	<i>Peng Jun</i>		



## Table of Contents

List	Description	Page No.
	Cover	1
	Revision Record	2
	Table of Contents	3
1	Scope	4
2	General Information	4
3	External Dimensions	5
4	Module Structure	6
5	Absolute Maximum Ratings	9
6	DC Characteristics	9
7	HDMI Scaler Chip Characteristics	10
8	Backlight Characteristics	12
9	Optical Characteristics	13
10	Reliability Test Conditions and Methods	15
11	Inspection Standard	16
12	Handling Precautions	22
13	Precaution for Use	23
14	Packing Method	23

## 1. Scope

This specification defines general provisions as well as inspection standards for TFT module supplied by AMSON electronics.

If the event of unforeseen problem or unspecified items may occur, naturally shall negotiate and agree to solution.

## 2. General Information

### 2.1 LCM

Item	Standard Values	Unit
LCD type	5.0" TFT	
Dot arrangement	800×R.G.B.×480	dots
Color filter array	RGB vertical stripe	
Display mode	Normally Black	
Convertor IC	RTD2660H	
Module size	120.7(W)×75.8(H)×12.04(T)	mm
Active area	108.0(W)×64.8(H)	mm
Interface	HDMI	
Operating temperature	-20 ~ +70	°C
Storage temperature	-30 ~ +80	°C
Weight	TBD	g

### 2.2 CTP

Item	Standard Values	Unit
Touch Panel Size	5.0"	
Touch type	Projective capacitive touch panel	
Input Method	Finger / 5 Points touch	
Output Interface	USB	
Hardness	≥6H	
IC	FT5426	
I2C Address (7 Bits)	0x38	
Operating temperature	-20 ~ +70	°C
Storage temperature	-30 ~ +80	°C

## 3. External Dimensions

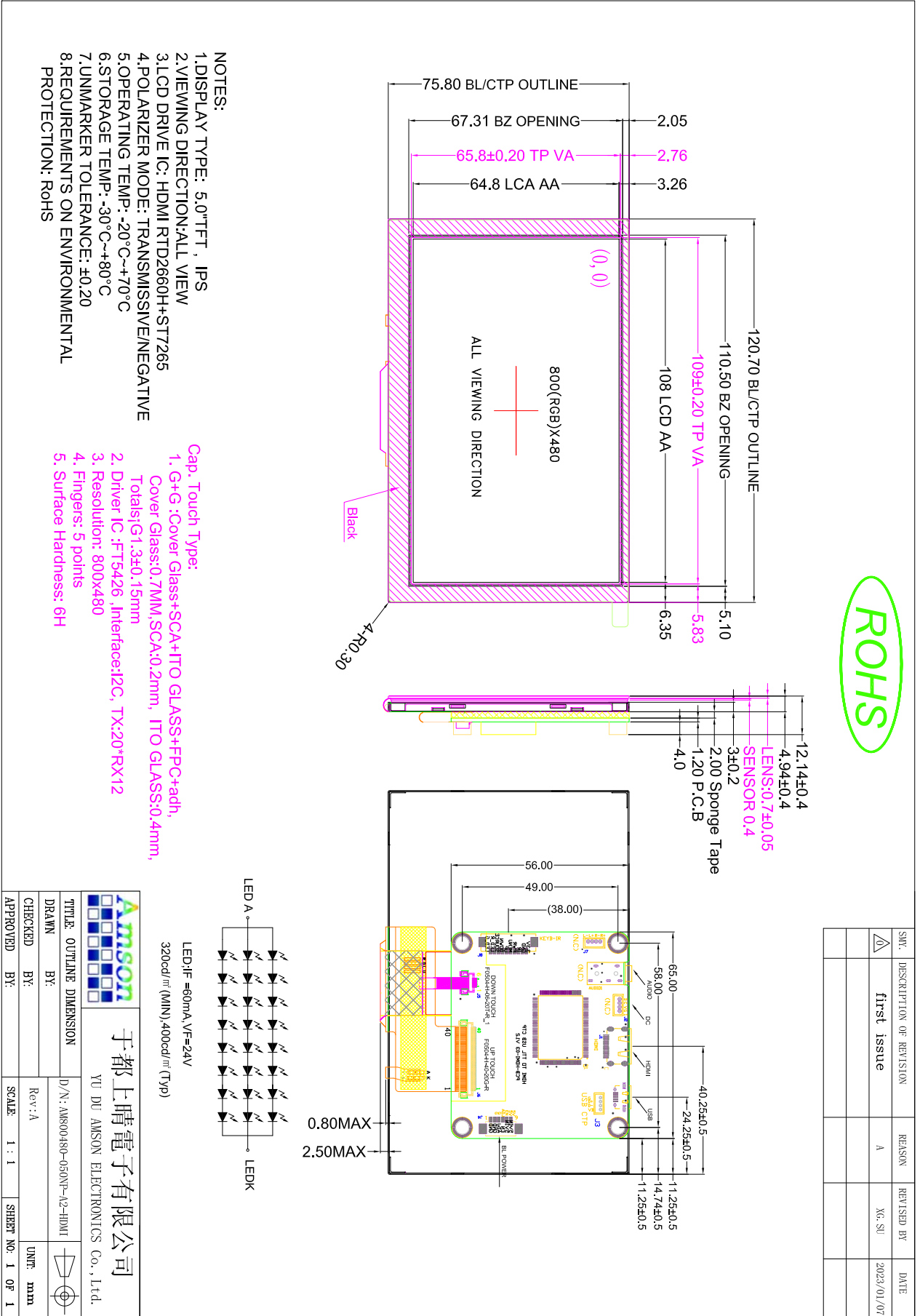

4. Module Structure  
4.1 Block Diagram

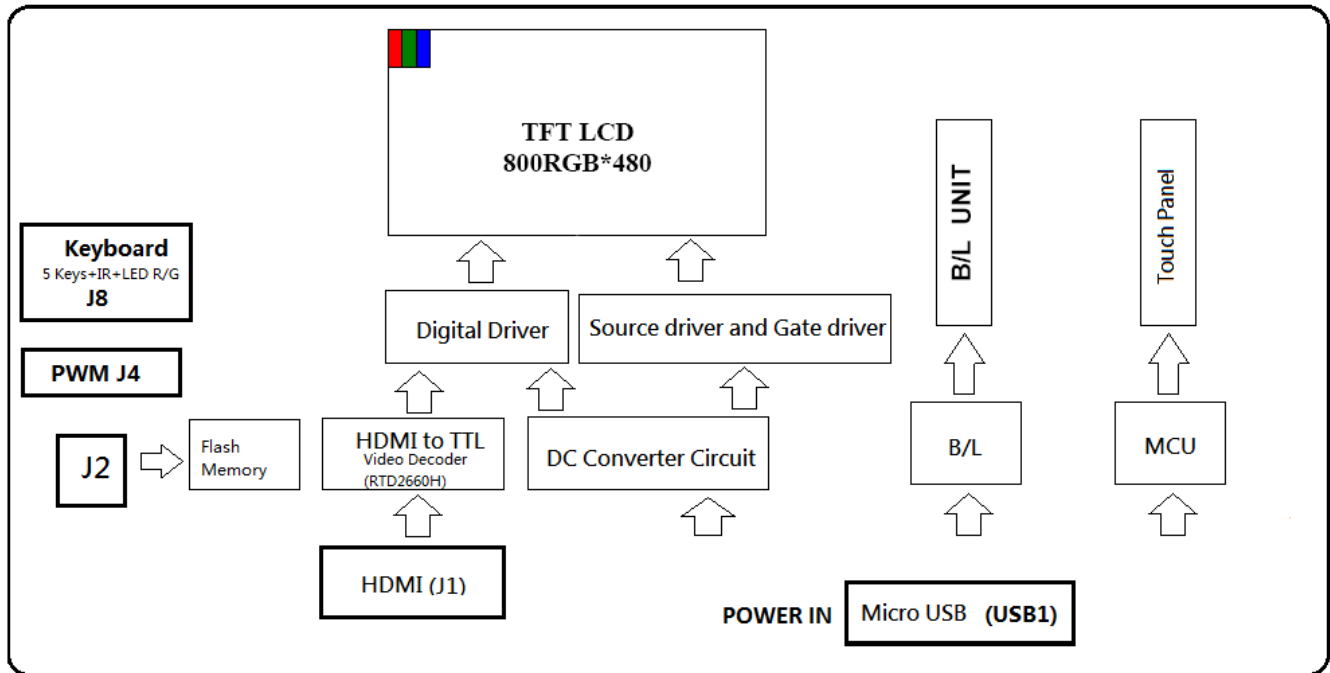

## 4.2 Interface Description

### 4.2.1 (J1:HDMI 1.3 / Mini HDMI Type C Interface)

Pin#	Name	Description
1	TX2 Shield	TMDS Data 2 Shield
2	TX2+	TMDS Data 2+
3	TX2-	TMDS Data 2-
4	TX1 Shield	TMDS Data 1 Shield
5	TX1+	TMDS Data 1+
6	TX1-	TMDS Data 1-
7	TX0 Shield	TMDS Data 0 Shield
8	TX0+	TMDS Data 0+
9	TX0-	TMDS Data 0-
10	TXC Shield	TMDS Clock Shield
11	TXC+	TMDS Clock+
12	TXC-	TMDS Clock-
13	DDC/CEC G	DDC/CEC GND
14	CEC	No Connection
15	SCL	Serial Clock for DDC
16	SDA	Serial Data for DDC
17	Reserved	No Connection
18	V5V	+5V Power
19	Hot Plug Detect	Hot Plug Detect

### 4.2.2 (USB1 :Micro USB Capacitive Touch Panel Interface and Power Input)

Pin#	Name	Description
1	VBUS	V <sub>Bus</sub> 4.4V-5.25V
2	D-	Data-
3	D+	Data+
4	ID	No Connection
5	GND	Power Ground.

### 4.2.3 (J4 : Backlight Dimming Interface CN: JST P1.25\*6 Pins or Equivalent )

Pin#	Name	Description	Note
1	VIN	V <sub>IN</sub> 5V, Power Supply Input	VBUS or VIN Choose one Power Supply Input
2	VIN	V <sub>IN</sub> 5V, Power Supply Input	
3	EN OUT	NC	RTD2660H GPIO PWM Output.
4	PWM IN	Brightness Dimming	0-3.3V APWM 1K-10K
5	GND	Power Ground.	
6	GND	Power Ground.	

### 4.2.5 (J8 : Keyboard Interface CN: JST P1.25\*10 Pins or Equivalent )

Pin	Pin Name	Description	Remark
1	VCC	Power supply output for Keyboard (+3.3V)	
2	GND	Ground	
3	IR	IR indicator	
4	POWER	Power Key	
5	MENU	Menu Key	
6	+	+ Key	
7	-	- Key	
8	SOURCE	Source Key	
9	R_LED	Red indicator	
10	G_LED	Green indicator	



## 5. Absolute Maximum Ratings

Item	Symbol	Min.	Max.	Unit	Remark
Supply Voltage	VIN	-0.3	6.5	V	
Supply Voltage	VBUS	-0.3	6.0	V	

## 6. DC Characteristics

### 6.1 LCM Parameters

Item	Symbol	Min.	Typ.	Max.	Unit	Remark
Power Voltage	VIN	4.5	5.0	5.5	V	Choose one
Power Voltage	VBUS	4.5	5.0	5.5	V	
Input logic high voltage	V <sub>IH</sub>	0.7*3V3	-	3V3	V	
Input logic low voltage	V <sub>IL</sub>	GND	-	0.3*3V3	V	
Output High Voltage	V <sub>OH</sub>	3V3-0.4	-	3V3	V	
Output Low Voltage	V <sub>OL</sub>	GND	-	GND+0.4	V	
Current for Power	I <sub>VIN</sub>	-	200	300	mA	VIN=5.0V
Current for Power	I <sub>VBUS</sub>	-	200	300	mA	VBUS=5.0V

### 6.2 CTP Parameters

Item	Symbol	Min.	Typ.	Max.	Unit	Remark
Input logic high voltage	V <sub>IH</sub>	0.7* 3V3	-	3V3	V	
Input logic low voltage	V <sub>IL</sub>	-0.3	-	0.3* 3V3	V	
Output High Voltage	V <sub>OH</sub>	0.7* 3V3	-	V3V	V	
Output Low Voltage	V <sub>OL</sub>	GND	-	0.3* 3V3	V	

## 7. HDMI Scaler Chip Characteristics

### 7.1 Chip Data Path Block Diagram

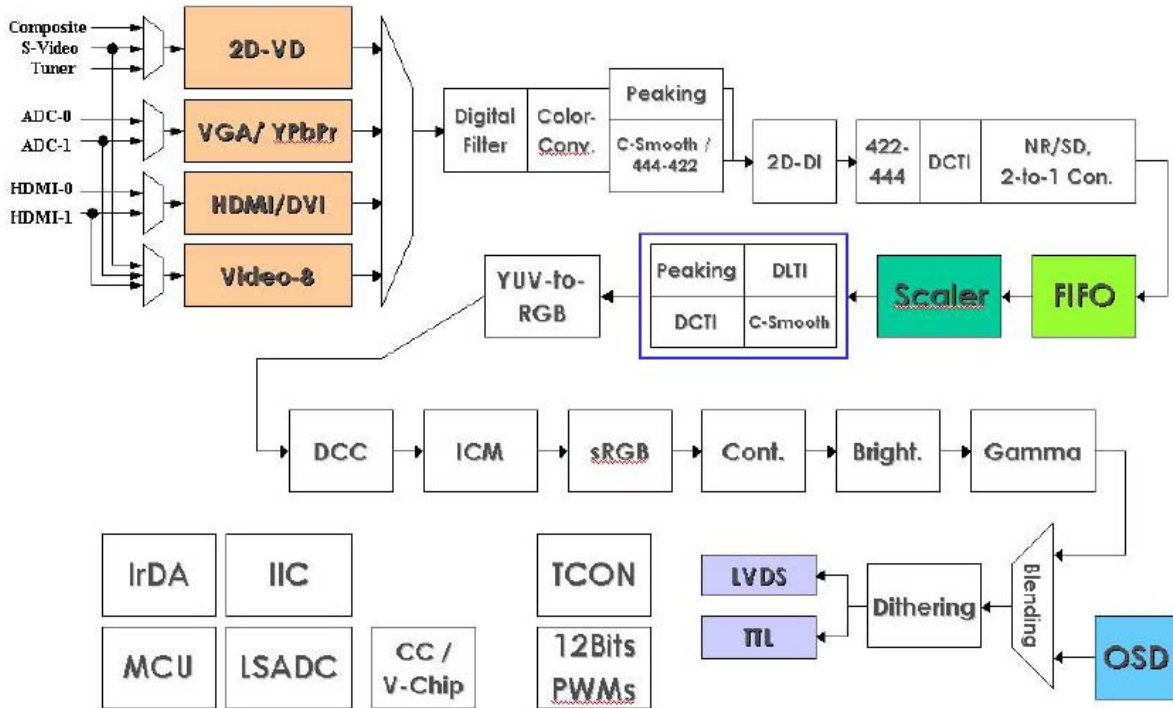

## 7.2 Electric characteristics

### DC Characteristics

Table 1 Absolute Maximum Ratings

PARAMETER	SYMBOL	MIN	TYP	MAX	UNITS
Voltage on Input (5V tolerant)	$V_{IN}$	-1		5	V
Electrostatic Discharge	$V_{ESD}$			±2.5	kV
Latch-Up	$I_{LA}$			±100	mA
Ambient Operating Temperature	$T_A$	0		70	°C
Storage temperature (plastic)	$T_{STG}$	-55		125	°C
Thermal Resistance (Junction to Air)	$\theta_{JA}$			25	°C/W
Junction Acceptable Temperature	$T_j$			125	°C

Table 2 DC Characteristics/Operating Condition

 $(0^{\circ}\text{C} < T_A < 70^{\circ}\text{C})$ 

#### 【Power consumption : Embedded MCU】

Dot-pattern(check\_11).

【1】 VGA-in: 1600x1200/75Hz , display to 1680x1050/75Hz , DCLK=170MHz.

Pattern Generator : 『 Chroma 2227 』 ; Pattern Name : 『 Dot 』 pattern

【2】 HDMI-in: 1600x1200/60Hz , display to 1680x1050/60Hz.

Pattern Generator : 『 QunatumData 882 』 ; Pattern Name : 『 Check11 』 (256 gray scale)

【3】 Video Decoder-in : DVD-player ; AV-in ; display to 1680x1050

Power Name	Voltage	Operating(mA)	Power saving(mA)	Power down(mA)
VCCK(core)(VGA)	1.8V	438	14.9	5.9
VCCK(core)(HDMI)	1.8V	455	8.5	6.1
VCCK(core)(Video Decoder)	1.8V	232	8.6	6.1
ADC_VDD	1.8V	123	0.1	0.1
TMDS_VDD	3.3V	173	19.9	19.9
VADC_VDD	3.3V	65.6	0.1	0.1
PVCC(LVDS)	3.3V	78.5	2.5	2.5
PVCC(TTL)	3.3V	34.1	12.8	12.8

### 7.3 Timing Table

Item	Symbol	Values			Unit
		Min.	Typ.	Max.	
Horizontal Display Area	thd	-	800	-	DCLK
DCLK Frequency	fclk	23	25	27	MHz
One Horizontal Line	th	808	816	848	DCLK
HS pulse width	thpw	2	4	8	DCLK
HS Blanking	thb	4	8	24	DCLK
HS Front Porch	thfp	4	8	24	DCLK

Item	Symbol	Values			Unit
		Min.	Typ.	Max.	
Vertical Display Area	tvd	-	480	-	TH
VS period time	tv	510	525	650	TH
VS pulse width	tvpw	2	4	8	TH
VS Blanking	tvb	8	16	24	TH
VS Front Porch	tvfp	8	16	24	TH

### 8. Backlight Characteristic

Item	Symbol	Min	Typ	Max	Unit	Remark
Luminous Intensity for LCM and TP	-	320	400	-	cd/m2	
Luminance uniformity	-	80	-	-	%	
Life Time	-	30000	-	-	Hr	
Color	White					

**9. Optical Characteristics**

Item	Conditions	Min.	Typ.	Max.	Unit	Note	
Viewing Angle (CR>10)	Horizontal	$\theta_L$	-	80	-	degree	(1),(2),(6)
		$\theta_R$	-	80	-		
	Vertical	$\theta_T$	-	80	-		
		$\theta_B$	-	80	-		
Contrast Ratio	Center	800	1000	-	-	(1),(3),(6)	
Response Time	Rising	-	30	40	ms	(1),(4),(6)	
	Falling	-	30	40			
CF Color Chromaticity (CIE1931)	Red x	Typ. -0.05	TBD	Typ. +0.05	-	(1), (6)	
	Red y		TBD		-		
	Green x		TBD		-		
	Green y		TBD		-		
	Blue x		TBD		-		
	Blue y		TBD		-		
	White x		0.310		-		
	White y		0.329		-		
NTSC		-	61.	-	%	(1),(6)	

Note (1) Measurement Setup: The LCD module should be stabilized at given temp. 25°C for 15 minutes to avoid abrupt temperature change during measuring. In order to stabilize the luminance, the measurement should be executed after lighting backlight for 15 minutes in a windless room.

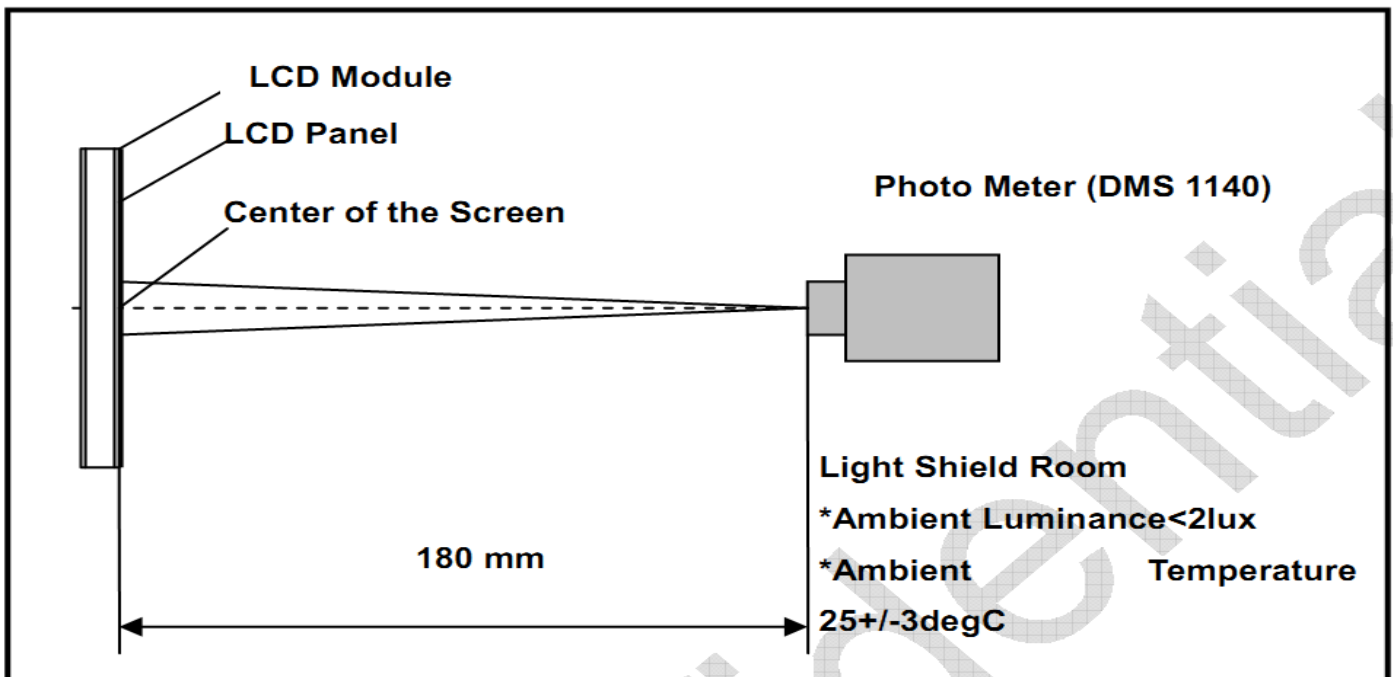

Note (2) Definition of Viewing Angle

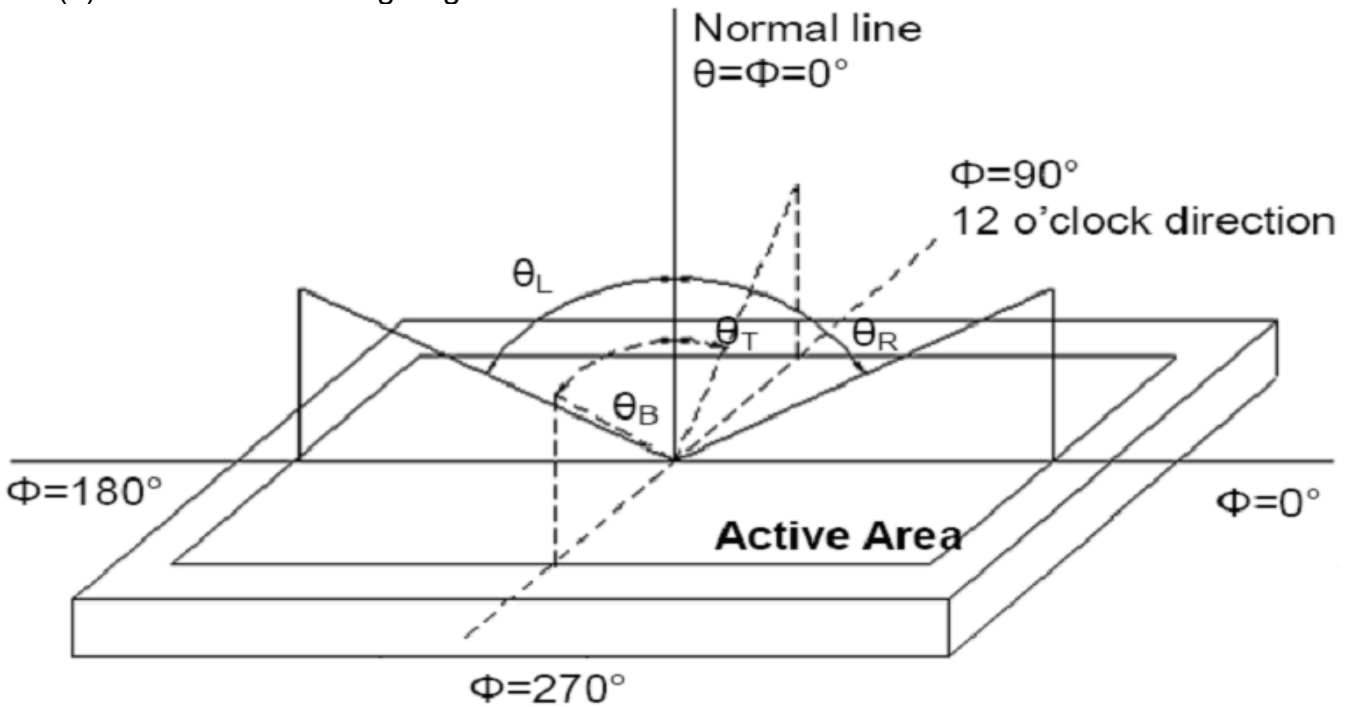

Note (3) Definition of Contrast Ratio (CR)

The contrast ratio can be calculated by the following expression

$$\text{Contrast Ratio (CR)} = L_{63} / L_0$$

L63: Luminance of gray level 63, L0: Luminance of gray level 0

Note (4) Definition of response time

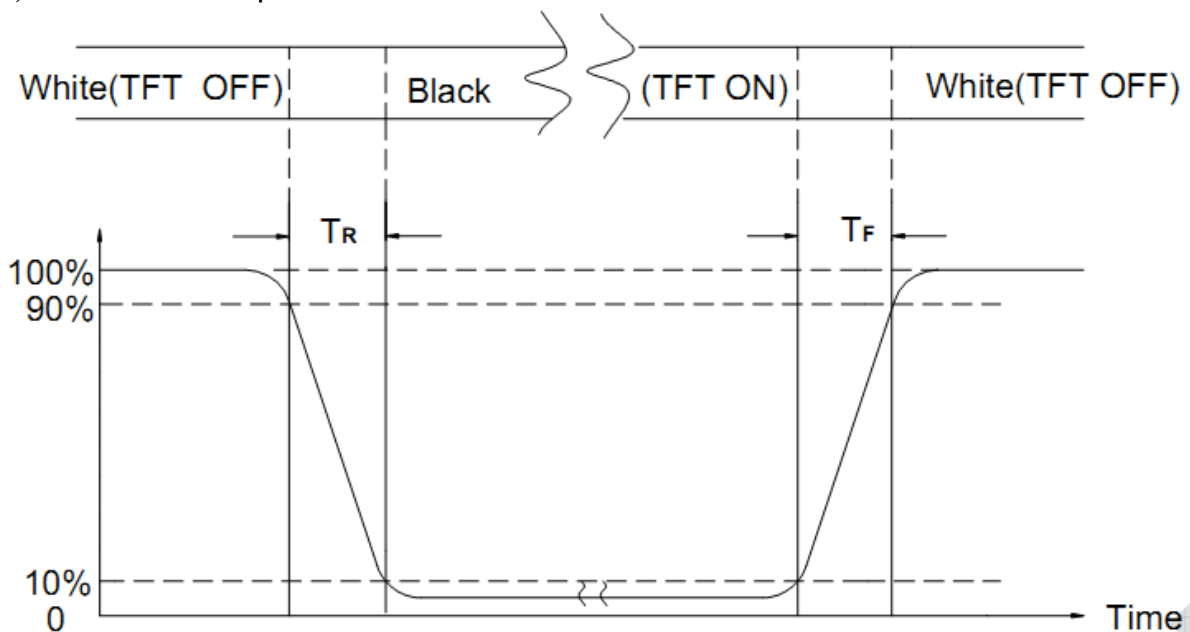

Note (5) Definition of Transmittance (Module is without signal input)

$$\text{Transmittance} = \text{Center Luminance of LCD} / \text{Center Luminance of Back Light} \times 100\%$$

Note (6) Definition of color chromaticity (CIE1931)

Color coordinates measured at the center point of LCD

**10. Reliability Test Conditions and Methods**

NO.	Test Items	Test Condition											
①	High Temperature Storage	Keep in 80°C±2°C×240Hrs Surrounding temperature, then storage at normal condition 4hrs.											
②	Low Temperature Storage	Keep in -30°C±2°C×240Hrs Surrounding temperature, then storage at normal condition 4hrs.											
③	High Temperature Operating	70°C±2°C×240Hours											
④	Low Temperature Operating	-20°C±2°C×240Hours											
⑤	High Temperature / High Humidity Storage Test	Keep in 60°C±5°C×90%RH×240Hrs Surrounding temperature, then storage at normal condition 4hrs.											
⑥	Temperature Cycling Storage Test	$  \begin{array}{ccccccc}  & -30^{\circ}\text{C} & \rightarrow & +25^{\circ}\text{C} & \rightarrow & 80^{\circ}\text{C} & \rightarrow & +25^{\circ}\text{C} \\  & (30\text{mins}) & & (5\text{mins}) & & (30\text{mins}) & & (5\text{mins}) \\  & & & \leftarrow & & \rightarrow & & \\  & & & & & \text{30 Cycle} & & \\  \end{array}  $ Surrounding temperature, then storage at normal condition 4hrs.											
⑦	ESD Test	Air Discharge: Apply 8 KV with 5 times Discharge for each polarity +/-	Contact Discharge: Apply 250 V with 5 times discharge for each polarity +/-										
		1. Temperature ambience : 15°C~35°C 2. Humidity relative : 30%~60% 3. Energy Storage Capacitance (Cs + Cd): 150pF±10% 4. Discharge Resistance (Rd): 330Ω±10% 5. Discharge, mode of operation: Single Discharge (time between successive discharges at least 1 sec) (Tolerance if the output voltage indication : ±5%)											
⑧	Vibration Test (Packaged)	1. Sine wave 10~55 Hz frequency (1 min/sweep) 2. The amplitude of vibration :1.5 mm 3. Each direction (X、Y、Z) duration for 2 Hrs											
⑨	Drop Test (Packaged)	<table border="1"> <thead> <tr> <th>Packing Weight (Kg)</th> <th>Drop Height (cm)</th> </tr> </thead> <tbody> <tr> <td>0 ~ 45</td> <td>122</td> </tr> <tr> <td>45.4 ~ 90.8</td> <td>76</td> </tr> <tr> <td>90.8 ~ 454</td> <td>61</td> </tr> <tr> <td>Over 454</td> <td>46</td> </tr> </tbody> </table>		Packing Weight (Kg)	Drop Height (cm)	0 ~ 45	122	45.4 ~ 90.8	76	90.8 ~ 454	61	Over 454	46
		Packing Weight (Kg)	Drop Height (cm)										
0 ~ 45	122												
45.4 ~ 90.8	76												
90.8 ~ 454	61												
Over 454	46												
		Drop Direction: ※1 corner / 3 edges / 6 sides each 1time											

## 11. Inspection Standard

### 11.1. Quality

The quality of goods supplied to purchaser shall come up to the following standards:

#### 11.1.1. Inspection Tools and Instruments

Vernier calipers, film scales, multimeter, magnifying eyepiece, ND5%, luminance meter and so on.

#### 11.1.2. The Method of Preserving Goods

After delivery of goods from AMSON to purchaser, purchaser shall keep the LCM at -10°C to 30°C, and it might be desirable to keep at the normal room temperature and humidity until incoming inspection or throwing into process line.

#### 11.1.3. Incoming Inspection

(A) The methods of Inspection

If purchaser makes an incoming inspection, a sampling plan shall be applied on the condition that quality of one delivery shall be regarded as one lot.

(B) The standard of quality:

ISO-2859-1 (same as MIL-STD-105E ), Level: II

CLASS	AQL (%)
Critical	0.4 %
Major	0.65 %
Minor	1.5 %

Every item shall be inspected according to the class.

(C) Measure

If as the result of above receiving inspection, a lot out is discovered, purchaser Shall inform seller of it within seven days. But first shipment within fourteen days.

#### 11.1.4. Warranty Policy

AMSON will provide one-year warranty for the products only if under Specification operating conditions. AMSON will replace new products for these defect products which are under warranty period and belong to the responsibility of AMSON.

## 11.2. Checking Condition

11.2.1 Checking direction shall be in the 45 degree area to face the sample.

11.2.2 Inspector shall see from over 300±25mm with bare eyes far from the sample.

11.2.3 Ambient Illumination:

0 ~30 Lux for functional inspection

500 ~ 1200 Lux for external appearance inspection.



11.2.4 Test Area:

11.2.5 Inspection should be carried out with rope electrostatic ring and static finger cover (both hands except small fingers must be worn)

11.2.6 The inspector may make a visual inspection or a comparative examination with a film ruler and a magnifying eyepiece. Individual defects shall be determined according to the limited samples.

11.2.7 Functional testing uses electrical testing fixtures or test fixtures required by customers.

11.2.8 The ion fan should be used when testing.

11.2.9 The principle of judgement:

11.2.9.1 If the defect outside the visual area does not affect the assembly and display, it will be judged as a good product.

11.2.9.2 Poor definition:  
**Pixel:**  
 A combination of three sub-pixels  
 (Red + Green + Blue).



**Dot:**  
 Any of the sub-pixels  
 (Red or Green or Blue).

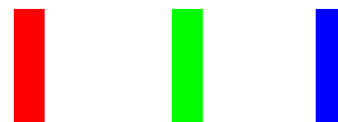

**Bright and dark dots:**  
 A point pixel (sub-pixel: R, G, B pixels) is lit or turned off during the display function test.

**Highlights:**  
 Usually considered to be shown on a black screen.

**Dark spots:**  
 They are generally considered to be shown on R, G, B solid colors or white images.

**Neighborhood:**  
 Two or three adjacent point pixels (dot: sub-pixel) connected together (R, G or G, B or B, R or RGB).

11.3 / 11.4 / 11.5 Inspection Plans:

CLASS	ITEM	JUDGEMENT	CLASS
PACKING & INDICATE	1. OUTSIDE AND INSIDE PACKAGE	"MODEL NO." , "LOT NO." AND "QUANTITY" SHOULD INDICATE ON THE PACKAGE.	Minor
	2. MODEL MIXED AND QUANTITY	OTHER MODEL MIXED.....REJECTED QUANTITY SHORT OR OVER.....REJECTED	Critical
	3. PRODUCT INDICATION	"MODEL NO." SHOULD INDICATE ON THE PRODUCT	Major
ASSEMBLY	4. DIMENSION, LCD GLASS SCRATCH AND SCRIBE DEFECT.	ACCORDING TO SPECIFICATION OR DRAWING.	Major
APPEARANCE	5. VIEWING AREA	POLARIZER EDGE OR LCD'S SEALING LINE IS VISABLE IN THE VIEWING AREA .....REJECTED	Minor
	6. BLEMISH · BLACK SPOT · WHITE SPOT IN THE LCD AND LCD GLASS CRACKS	ACCORDING TO STANDARD OF VISUAL INSPECTION(INSIDE VIEWING AREA)	Minor
	7. BLEMISH · BLACK SPOT WHITE SPOT AND SCRATCH ON THE POLARIZER	ACCORDING TO STANDARD OF VISUAL INSPECTION(INSIDE VIEWING AREA)	Minor
	8. BUBBLE IN POLARIZER	ACCORDING TO STANDARD OF VISUAL INSPECTION(INSIDE VIEWING AREA)	Minor
	9. LCD'S RAINBOW COLOR	STRONG DEVIATION COLOR ( OR NEWTON RING) OF LCD.....REJECTED. OR ACCORDING TO LIMITED SAMPLE ( IF NEEDED, AND INSIDE VIEWING AREA )	Minor
ELECTRICAL	10. ELECTRICAL AND OPTICAL CHARACTERISTICS ( CONTRAST· VOP · CHROMATICITY ... ETC )	ACCORDING TO SPECIFICATION OR DRAWING . ( INSIDE VIEWING AREA )	Critical
	11.MISSING LINE	MISSING DOT· LINE · CHARACTER .....REJECTED	Critical
	12.SHORT CIRCUIT· WRONG PATTERN DISPLAY	NO DISPLAY · WRONG PATTERN DISPLAY · CURRENT CONSUMPTION OUT OF SPECIFICATION..... REJECTED	Critical
	13. DOT DEFECT (FOR COLOR AND TFT)	ACCORDING TO STANDARD OF VISUAL INSPECTION	Minor

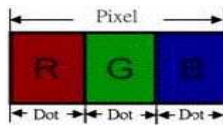
NO.	CLASS	ITEM	JUDGEMENT									
11.4.1	MINOR	BLACK AND WHITE SPOT FOREIGN MATERIEL DUST IN THE CELL BLEMISH SCRATCH	(A) ROUND TYPE: <span style="float: right;">unit: mm</span> <table border="1" style="width: 100%; text-align: center;"> <thead> <tr> <th>DIAMETER (mm.)</th> <th>ACCEPTABLE Q'TY</th> </tr> </thead> <tbody> <tr> <td><math>\varnothing \leq 0.1</math></td> <td>Disregard</td> </tr> <tr> <td><math>0.1 &lt; \varnothing \leq 0.25</math></td> <td>3 (Distance <math>\geq 5\text{mm}</math>)</td> </tr> <tr> <td><math>0.25 &lt; \varnothing</math></td> <td>0</td> </tr> </tbody> </table> <p style="text-align: center;">NOTE: <math>\varnothing = (\text{LENGTH} * \text{WIDTH}) / 2</math></p>	DIAMETER (mm.)	ACCEPTABLE Q'TY	$\varnothing \leq 0.1$	Disregard	$0.1 < \varnothing \leq 0.25$	3 (Distance $\geq 5\text{mm}$ )	$0.25 < \varnothing$	0	
			DIAMETER (mm.)	ACCEPTABLE Q'TY								
$\varnothing \leq 0.1$	Disregard											
$0.1 < \varnothing \leq 0.25$	3 (Distance $\geq 5\text{mm}$ )											
$0.25 < \varnothing$	0											
(S) ROUND TYPE: <span style="float: right;">unit: mm</span> <table border="1" style="width: 100%; text-align: center;"> <thead> <tr> <th>LENGTH</th> <th>WIDTH</th> <th>ACCEPTABLE QTY</th> </tr> </thead> <tbody> <tr> <td>.....</td> <td><math>W \leq 0.03</math></td> <td>Disregard</td> </tr> <tr> <td><math>L \leq 5.0</math></td> <td><math>0.03 &lt; W \leq 0.07</math></td> <td>3 (Distanced <math>\geq 5\text{mm}</math>)</td> </tr> <tr> <td>.....</td> <td><math>0.07 &lt; W</math></td> <td>FOLLOW ROUND TYPE</td> </tr> </tbody> </table> <p style="text-align: center;">NOTE: <math>\varnothing = (\text{LENGTH} * \text{WIDTH}) / 2</math></p>	LENGTH	WIDTH	ACCEPTABLE QTY	.....	$W \leq 0.03$	Disregard	$L \leq 5.0$	$0.03 < W \leq 0.07$	3 (Distanced $\geq 5\text{mm}$ )	.....	$0.07 < W$	FOLLOW ROUND TYPE
LENGTH	WIDTH	ACCEPTABLE QTY										
.....	$W \leq 0.03$	Disregard										
$L \leq 5.0$	$0.03 < W \leq 0.07$	3 (Distanced $\geq 5\text{mm}$ )										
.....	$0.07 < W$	FOLLOW ROUND TYPE										
11.4.2	MINOR	BUBBLE IN POLARIZER DENT ON POLARIZER	unit: mm. <table border="1" style="width: 100%; text-align: center;"> <thead> <tr> <th>DIAMETER</th> <th>ACCEPTABLE Q'TY</th> </tr> </thead> <tbody> <tr> <td><math>\varnothing &lt; 0.2</math></td> <td>Disregard</td> </tr> <tr> <td><math>0.2 &lt; \varnothing \leq 0.5</math></td> <td>2(Distance <math>\geq 15\text{mm}</math>)</td> </tr> <tr> <td><math>0.5 &lt; \varnothing</math></td> <td>0</td> </tr> </tbody> </table>	DIAMETER	ACCEPTABLE Q'TY	$\varnothing < 0.2$	Disregard	$0.2 < \varnothing \leq 0.5$	2(Distance $\geq 15\text{mm}$ )	$0.5 < \varnothing$	0	
DIAMETER	ACCEPTABLE Q'TY											
$\varnothing < 0.2$	Disregard											
$0.2 < \varnothing \leq 0.5$	2(Distance $\geq 15\text{mm}$ )											
$0.5 < \varnothing$	0											
11.4.3	MINOR	Dot Defect	<table border="1" style="width: 100%; text-align: center;"> <thead> <tr> <th>Items</th> <th>ACC. Q'TY</th> </tr> </thead> <tbody> <tr> <td>Bright dot</td> <td><math>N \leq 4</math>(Distance <math>\geq 5\text{mm}</math>)</td> </tr> <tr> <td>Dark dot</td> <td><math>N \leq 4</math>(Distance <math>\geq 5\text{mm}</math>)</td> </tr> </tbody> </table> <p>Pixel Define :</p>  <p>Note:</p> <ol style="list-style-type: none"> <li>The definition of dot: The size of a defective dot over 1 of whole dot is regarded as one defective dot. Definition: <math>&lt; 1/2</math> dot and visible by 5% ND filter</li> <li>Bright dot: Dots appear bright and unchanged in size m which LCD panel is displaying under black pattern.</li> <li>Dark dot: Dots appear dark and unchanged in size in which LCD panel is displaying under pure Red, Green, Blue pattern.</li> </ol>	Items	ACC. Q'TY	Bright dot	$N \leq 4$ (Distance $\geq 5\text{mm}$ )	Dark dot	$N \leq 4$ (Distance $\geq 5\text{mm}$ )			
Items	ACC. Q'TY											
Bright dot	$N \leq 4$ (Distance $\geq 5\text{mm}$ )											
Dark dot	$N \leq 4$ (Distance $\geq 5\text{mm}$ )											
11.4.3.1	MINOR	Mura	Not visible through 5% ND filter in 50% gray or judge by limit sample if necessary									

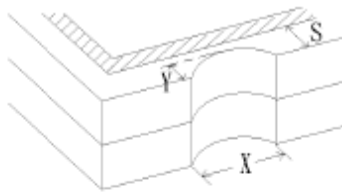
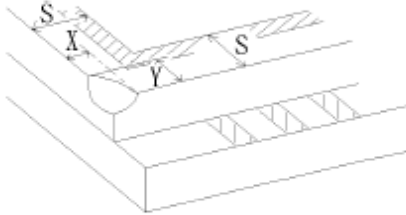
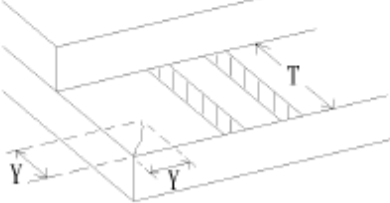
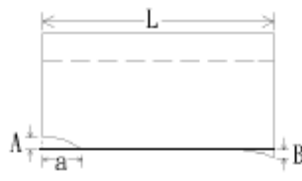
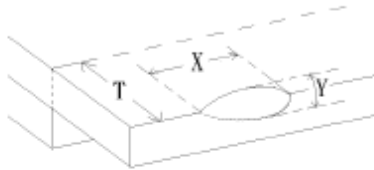
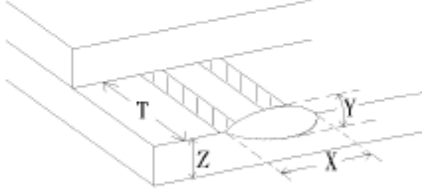
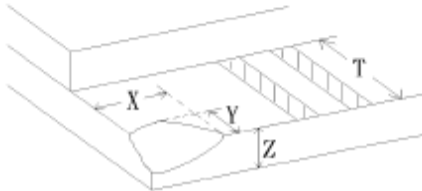
NO.	CLASS	ITEM	JUDGEMENT
11.4.4	MINOR	LCD GLASS CHIPPING	 $Y > S$ Reject
11.4.5	MINOR	LCD GLASS CHIPPING	 $X \text{ or } Y > S$ Reject
11.4.6	MAJOR	LCD GLASS GLASS CRACK	 $Y > (1/2) T$ Reject
11.4.7	MAJOR	LCD GLASS SCRIBE DEFECT	 <ol style="list-style-type: none"> <li><math>a &gt; L/3</math>, <math>A &gt; 1.5\text{mm}</math>. Reject</li> <li>B : ACCORDING TO DIMENSION</li> </ol>
11.4.8	MINOR	LCD GLASS CHIPPING ( ON THE TERMINAL AREA )	 $\Phi = (x+y)/2 > 2.5 \text{ mm}$ Reject
11.4.9	MINOR	LCD GLASS CHIPPING ( ON THE TERMINAL SURFACE )	 $Y > (1/3) T$ Reject
11.4.10	MINOR	LCD GLASS CHIPPING	 $Y > T$ Reject

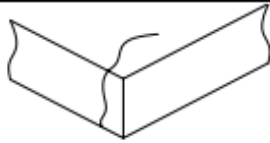
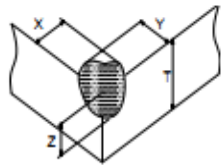
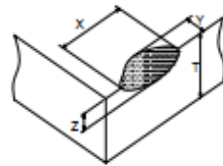
NO.	CLASS	ITEMS	JUDGEMENT						
11.5.1	MAJOR	Touch Panel Crack	 Reject						
11.5.2	MINOR	Touch Panel Chipping	Corner  <table border="1" style="display: inline-table; vertical-align: top;"> <tr> <td>Not CNC Products</td> <td><math>X \leq 2\text{mm}, Y \leq 2\text{mm}, Z &lt; 1/2T</math></td> <td>Accept</td> </tr> <tr> <td>CNC Products</td> <td>For CNC Outline Dimension</td> <td>Accept</td> </tr> </table>	Not CNC Products	$X \leq 2\text{mm}, Y \leq 2\text{mm}, Z < 1/2T$	Accept	CNC Products	For CNC Outline Dimension	Accept
			Not CNC Products	$X \leq 2\text{mm}, Y \leq 2\text{mm}, Z < 1/2T$	Accept				
CNC Products	For CNC Outline Dimension	Accept							
Edge  <table border="1" style="display: inline-table; vertical-align: top;"> <tr> <td>Not CNC Products</td> <td><math>X \leq 3\text{mm}, Y \leq 3\text{mm}, Z &lt; 1/2T</math></td> <td>Accept</td> </tr> <tr> <td>CNC Products</td> <td>For CNC Outline Dimension</td> <td>Accept</td> </tr> </table>	Not CNC Products	$X \leq 3\text{mm}, Y \leq 3\text{mm}, Z < 1/2T$	Accept	CNC Products	For CNC Outline Dimension	Accept			
Not CNC Products	$X \leq 3\text{mm}, Y \leq 3\text{mm}, Z < 1/2T$	Accept							
CNC Products	For CNC Outline Dimension	Accept							
11.5.3	MINOR	Scratch Dust and Foreign materiel (Linear Type)	$W \leq 0.05, L \leq 10\text{mm}$ Accept						
			$0.05\text{mm} < W \leq 0.07\text{mm}; L \leq 5.0\text{mm}$ Distance between scratch $> 5.0\text{mm}$ Accept 3 ea Max.						
			$W > 0.07\text{mm}$ Reject						
11.5.4	MINOR	Scratch Dust and Foreign materiel (Round Type : $\Phi = (\text{Length} + \text{Width})/2$ )	$\Phi \leq 0.15\text{mm}$ Accept						
			$0.15\text{mm} < \Phi \leq 0.25\text{mm}$ Distance between scratch $> 5.0\text{mm}$ Accept 5 ea Max.						
			$\Phi > 0.25\text{mm}$ Reject						
11.5.5	MINOR	Touch Panel Dent / Fish Eyes ( $\Phi = (\text{Length} + \text{Width})/2$ )	$\Phi \leq 0.35\text{mm}$ Accept						
			$0.35\text{mm} < \Phi \leq 1.0\text{mm}$ Distance $> 5.0\text{mm}$ Accept 3 ea Max.						
			$\Phi > 1.0\text{mm}$ Reject						
11.5.6	MINOR	Touch Panel Air Bubble ( $\Phi = (\text{Length} + \text{Width})/2$ )	$\Phi \leq 0.15\text{mm}$ Accept						
			$0.15\text{mm} < \Phi \leq 0.25\text{mm}$ Distance between bubbles $> 5.0\text{mm}$ Accept 3 ea Max.						
			$\Phi > 0.25\text{mm}$ Reject						
11.5.7	MINOR	Touch Panel Printing area Scratch	$W \leq 0.03, L \leq 10\text{mm}$ Accept						
			$0.03\text{mm} < W \leq 0.05\text{mm}, L \leq 5\text{mm}$ Accept 3 ea Max.						
			$W > 0.05\text{mm}$ or $L > 5\text{mm}$ ( $W > 0.05$ Follow 8.5.4 Round type ) Reject						
11.5.8	MINOR	Touch Panel White Haze Mark / Dust	Can not be removed Reject						

## 12. Handling Precautions

### 12.1 Mounting method

The LCD panel of AMSON TFT module consists of two thin glass plates with polarizers which easily be damaged. And since the module is so constructed as to be fixed by utilizing fitting holes in the printed circuit board.

Extreme care should be needed when handling the LCD modules.

### 12.2 Caution of LCD handling and cleaning

When cleaning the display surface, Use soft cloth with solvent

[Recommended below] and wipe lightly

- Isopropyl alcohol
- Ethyl alcohol

Do not wipe the display surface with dry or hard materials that will damage the polarizer surface.

Do not use the following solvent:

- Water
- Aromatics

Do not wipe ITO pad area with the dry or hard materials that will damage the ITO patterns

Do not use the following solvent on the pad or prevent it from being contaminated:

- Soldering flux
- Chlorine (Cl) , Sulfur (S)

If goods were sent without being silicon coated on the pad, ITO patterns could be damaged due to the corrosion as time goes on.

If ITO corrosion happens by miss-handling or using some materials such as Chlorine (Cl), Sulfur (S) from customer, Responsibility is on customer.

### 12.3 Caution against static charge

The LCD module uses C-MOS LSI drivers, so we recommend that you:

Connect any unused input terminal to power or ground, do not input any signals before power is turned on, and ground your body, work/assembly areas, and assembly equipment to protect against static electricity.

### 12.4 packing

- Module employs LCD elements and must be treated as such.
- Avoid intense shock and falls from a height.
- To prevent modules from degradation, do not operate or store them exposed direct to sunshine or high temperature/humidity

### 12.5 Caution for operation

- It is an indispensable condition to drive LCD's within the specified voltage limit since the higher voltage than the limit causes the shorter LCD life.
- An electrochemical reaction due to direct current causes LCD's undesirable deterioration, so that the use of direct current drive should be avoided.
- Response time will be extremely delayed at lower temperature than the operating temperature range and on the other hand at higher temperature LCD's show dark color in them. However those phenomena do not mean malfunction or out of order with LCD's, which will come back in the specified operation temperature.
- If the display area is pushed hard during operation, some font will be abnormally displayed but it resumes normal condition after turning off once.
- Slight dew depositing on terminals is a cause for electro-chemical reaction resulting in terminal open circuit.

Usage under the maximum operating temperature, 50%Rh or less is required.

## 12.6 storing

In the case of storing for a long period of time for instance, for years for the purpose or replacement use, the following ways are recommended.

- Storage in a polyethylene bag with the opening sealed so as not to enter fresh air outside in it. And with no desiccant.
- Placing in a dark place where neither exposure to direct sunlight nor light's keeping the storage temperature range.
- Storing with no touch on polarizer surface by the anything else.  
[It is recommended to store them as they have been contained in the inner container at the time of delivery from us.]

## 12.7 Safety

- It is recommendable to crash damaged or unnecessary LCD's into pieces and wash off liquid crystal by either of solvents such as acetone and ethanol, which should be burned up later.
- When any liquid leaked out of a damaged glass cell comes in contact with your hands, please wash it off well with soap and water.

## 13. Precaution for Use

### 13.1

A limit sample should be provided by the both parties on an occasion when the both parties agreed its necessity. Judgment by a limit sample shall take effect after the limit sample has been established and confirmed by the both parties.

### 13.2

On the following occasions, the handing of problem should be decided through discussion and agreement between responsible of the both parties.

- When a question is arisen in this specification.
- When a new problem is arisen this is not specified in this specification.
- When an inspection specifications change or operating condition change in customer is reported to AMSON TFT and some problem is arisen in this specification due to the change.
- When a new problem is arisen at the customer's operating set for sample evaluation in the customer site.

## 14. Packing Method

TBD