



# Specification for Approval

Customer: \_\_\_\_\_

Model Name: \_\_\_\_\_

Supplier Approval			Customer approval
R&D Designed	R&D Approved	QC Approved	
<i>Peter</i>	<i>Peng Jun</i>		

## Revision Record

REV NO.	REV DATE	CONTENTS	Note
A	2023-02-24	NEW ISSUE	

## Table of Contents

List	Description	Page No.
	Cover	1
	Revision Record	2
	Table of Contents	3
1	Scope	4
2	General Information	4
3	External Dimensions	5
4	Module Structure	6
5	Absolute Maximum Ratings	8
6	DC Characteristics	8
7	Timing Characteristics	9
8	Backlight Characteristics	10
9	Optical Characteristics	11
10	Reliability Test Conditions and Methods	13
11	Inspection Standard	14
12	Handling Precautions	19
13	Precaution for Use	20
14	Packing Method	20

## 1. Scope

This specification defines general provisions as well as inspection standards for TFT module supplied by AMSON electronics.

If the event of unforeseen problem or unspecified items may occur, naturally shall negotiate and agree to solution.

## 2. General Information

### LCM

ITEM	STANDARD VALUES	UNIT
LCD Type	5.0" TFT	-
Dot Arrangement	800(RGB)×480	dots
Color Filter Array	RGB vertical stripe	-
Display mode	Normally BLACK IPS	-
Viewing Direction	ALL	-
Module Size	120.7(W)×75.8(H)×6.2(T)	mm
Active Area	108 (W)×64.8(H)	mm
Interface	3-wire SPI、4-wire SPI、QSPI interface	-
Operating Temperature	-20 ~ +70	°C
Storage Temperature	-30 ~ +80	°C
Back Light	24 White LEDs	-

### CTP

ITEM	STANDARD VALUES	UNIT
CTP Type	Cover Lens + sensor Film + sensor Film + FPC	--
Driver IC	FT5426	--
Surface Hardness	6H	--
Transmittance	≥85%	--
Viewing Area	109(W)×65.8(H)	mm
Interface	I <sup>2</sup> C	-
I2C Address	0x70(8bit), 0x38 (7bit);	
Operating Temperature	-20 ~ +70	°C
Storage Temperature	-30 ~ +80	°C

### 3. External Dimensions

**ROHS**

**NOTES:**

- 1.DISPLAY TYPE: 5.0" TFT, IPS
- 2.VIEWING DIRECTION: ALL VIEW
- 3.LCD DRIVE IC: FT813+ST7265
- 4.POLARIZER MODE: TRANSMISSIVE/NEGATIVE
- 5.OPERATING TEMP: -20°C~+70°C
- 6.STORAGE TEMP: -30°C~+80°C
- 7.UNMARKER TOLERANCE: ±0.20
- 8.REQUIREMENTS ON ENVIRONMENTAL PROTECTION: RoHS

**9. Cap. Touch Type:**

- 9.1 G+G: Cover Glass+SCA+ITO GLASS+FFC+adh.  
Cover Glass: 0.7MM, SCA: 0.2mm, ITO GLASS: 0.4mm, Totals: G1.3±0.15mm
- 9.2 Driver IC: FT5426, Interface: I2C, TX: 20°RX: 12
- 9.3 Resolution: 800x480
- 9.4 Fingers: 5 points
- 9.5 Surface Hardness: 6H

**LED: IF = 60mA, VF = 24V**  
640cd/m<sup>2</sup> (MIN), 800cd/m<sup>2</sup> (Typ)

**J1 Definition**

Pin	Definition
1	GND
2	GND
3	SPI_VCC
4	CS
5	GND
6	SPI_MOSI
7	SPI_MISO
8	GND
9	GND
10	AUX_VCC
11	AUX_VCC/GND
12	DRIVE_VCC
13	DRIVE_GND
14	GND
15	GND
16	GND
17	GND
18	GND
19	GND
20	GND

**Component Area**

**Dimensions:**

- 75.80 ± 0.20 BL/CTP OUTLINE
- 67.31 ± 0.20 BZ OPENING
- 65.8 ± 0.20 TP VA
- 64.8 LCA AA
- 120.70 ± 0.20 BL/CTP OUTLINE
- 110.50 ± 0.20 BZ OPENING
- 109 ± 0.20 TP VA
- 108 LCD AA
- 5.10
- 5.83
- 6.35
- 2.05
- 2.76
- 3.26
- (0, 0)
- 800(RGB)X480
- ALL VIEWING DIRECTION
- BLACK
- A-R0.3
- 6.2 ± 0.4
- 4.94 ± 0.4
- LENS: 0.7 ± 0.05
- SENSOR 0.4
- 3 ± 0.2
- 1.2 PCB
- (8, 8)
- 30.0 ± 0.5 (PCB)
- (5.0)
- 100.0 ± 0.5 (PCB)
- 10.1 ± 0.8
- 0.8 MAX
- 2.5 MAX

**于都上晴電子有限公司**  
YU DU AMSON ELECTRONICS Co., Ltd.

**Amson**

**TITLE: OUTLINE DIMENSION**

D/N: AM800480-050NP-B1-SPI

Rev: A

SCALE: 1 : 1

DATE: 2023/02/24

REVISED BY: XG.SU

REASON: first issue

DESCRIPTION OF REVISION

SMV

## 4. Module Structure

### 4.1 Interface Description

PIN	PIN NAME	DESCRIPTION
1	GND	Power ground
2	SPI_PD	Chip power down mode control input, active low.
3	SPI_INT	Interrupt to host, open drain output(default) or push-pull output, active low.
4	CS	SPI slave select input
5	GND	Power ground
6	SPI_MOSI	SPI Single mode: SPI MOSI input SPI Dual/Quad mode: SPI data line 0
7	SPI_MISO	SPI Single mode: SPI MISO output SPI Dual/Quad mode: SPI data line 1
8	SPI_SCK	SPI clock input
9	GND	Power ground
10	AUD_PWM	Audio PWM out
11	AUD_PD/GPIO2	General purpose IO 2
12	GPIO_0/IO2	SPI Single/Dual mode: General purpose IO 0 SPI Quad mode: SPI data line 2
13	GPIO_1/IO3	SPI Single/Dual mode: General purpose IO 1 SPI Quad mode: SPI data line 3
14	GPIO_3	General purpose IO 3
15	GND	Power ground
16	GND	Power ground
17	GND	Power ground
18	+5V	Supply voltage to the analog circuit.
19	+5V	Supply voltage to the analog circuit.
20	+5V	Supply voltage to the analog circuit.

## 4.2 Block Diagram

FT813 with EVE (Embedded Video Engine) technology simplifies the system architecture for advanced Human Machine Interfaces (HMIs) by providing support for display, touch, and audio as well as an object oriented architecture approach that extends from display creation to the rendering of the graphics.

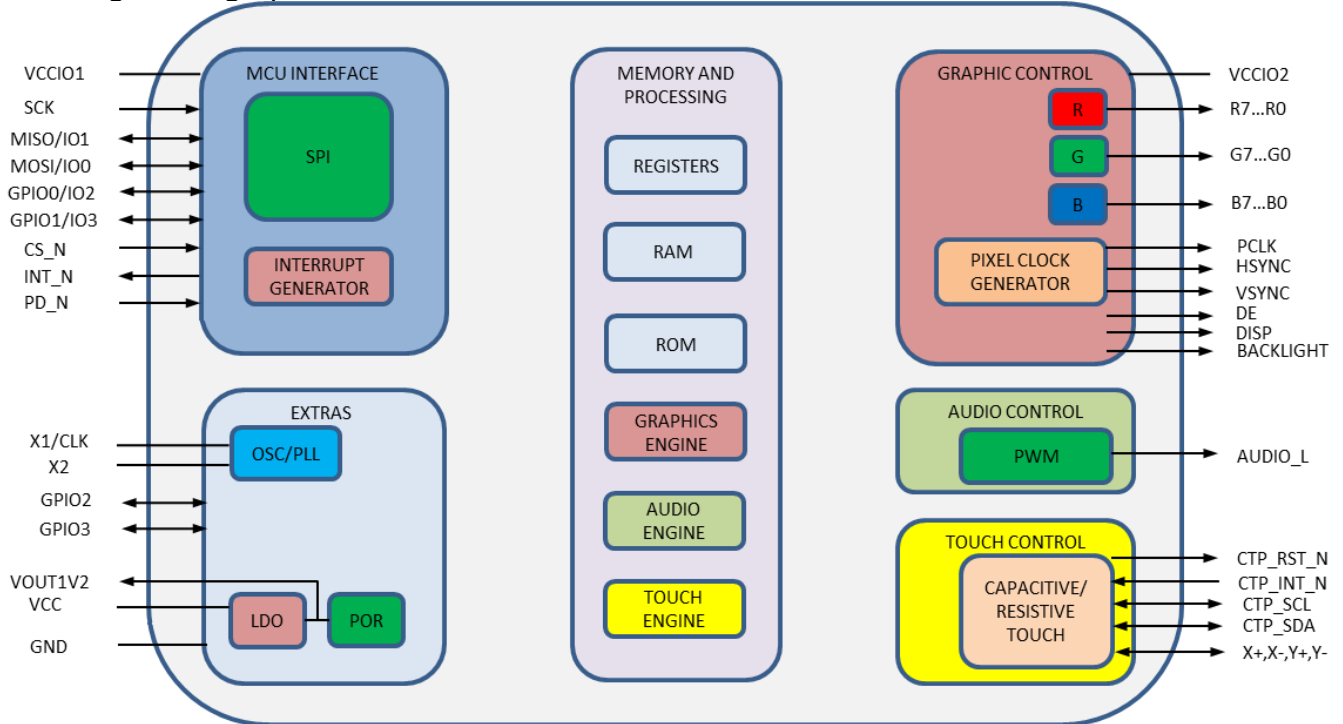

## 4.3 Serial Host Interface

By default the SPI slave operates in the SINGLE channel mode with MOSI as input from the master and MISO as output to the master. DUAL and QUAD channel modes can be configured through the SPI slave itself. To change the channel modes, write to register REG\_SPI\_WIDTH. Please refer to the table below:

REG_SPI_WIDTH[1:0]	Channel Mode	Data Pins	Max Bus Speed
00	SINGLE(default)	MISO, MOSI	30MHz
01	DUAL	IO0, IO1	30MHz
10	QUAD	IO0, IO1, IO2 IO3	25MHz
11	Reserved	-	-

For more details on the FT81X SPI interface, please refer to pages 13-15 of the official FT81x Datasheet:

[http://www.ftdichip.com/Support/Documents/DataSheets/ICs/DS\\_FT81x.pdf](http://www.ftdichip.com/Support/Documents/DataSheets/ICs/DS_FT81x.pdf)

For the REG\_SPI\_WIDTH register definition, please refer to page 87 of the official FT81x Series Programmers Guide:

[http://www.ftdichip.com/Support/Documents/ProgramGuides/FT81X\\_Series\\_Programmer\\_Guide.pdf](http://www.ftdichip.com/Support/Documents/ProgramGuides/FT81X_Series_Programmer_Guide.pdf)

## 5. Absolute Maximum Ratings

Item	Symbol	Min.	Max.	Unit
Input Voltage	+5V	-0.3	6.0	V
Operating Temperature	T <sub>OP</sub>	-20	70	°C
Storage Temperature	T <sub>ST</sub>	-30	80	°C

## 6. DC Characteristics

Item	Symbol	Min.	Typ.	Max.	Unit	Remark
Analog Supply Voltage	+5V	4.5	5.0	5.5	V	-
Input High Voltage	V <sub>IH</sub>	2.0	-	3.3	V	-
Input Low Voltage	V <sub>IL</sub>	GND	-	0.8	V	-
Output High Voltage	V <sub>OH</sub>	2.9	-	3.3	V	-
Output Low Voltage	V <sub>OL</sub>	GND	-	0.4	V	-
Supply Current	I <sub>+5V</sub>		500	650	mA	+5V= 5V



## 7. Timing Characteristics

### 7.1 SPI interface timing

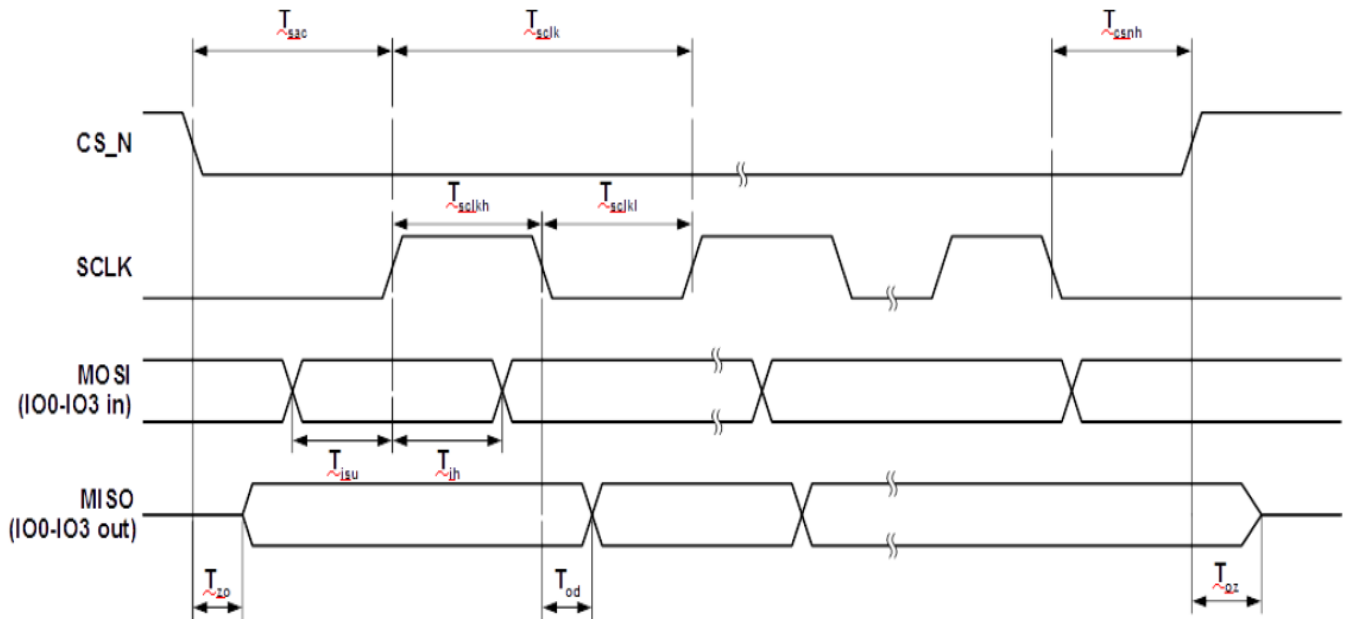

Parameter	Description	Min	Max	Units
Tsclk	SPI clock period(SINGLE/DUAL mode)	33.3	-	ns
Tsclk	SPI clock period (QUAD mode)	13	-	ns
Tsckl	SPI clock low duration	13	-	ns
Tsclkh	SPI clock high duration	13	-	ns
Tsac	SPI access time	3	-	ns
Tisu	Input Setup	3	-	ns
Tih	Input Hold	0	-	ns
Tzo	Output enable delay	-	11	ns
Toz	Output disable delay	-	10	ns
Tod	Output data delay	-	11	ns
Tcsnh	CSN hold time	0	-	ns

## 7.2 Timing Table

Parallel 24-bit RGB Interface Timing Table						
Item	Symbol	Min.	Typ.	Max.	Unit	Remark
DCLK Frequency	Fclk	23	25	27	MHz	
HSYNC	Period Time	Th	808	816	896	DCLK
	Display Period	Thdisp	800			DCLK
	Back Porch	Thbp	4	8	48	DCLK
	Front Porch	Thfp	4	8	48	DCLK
	Pulse Width	Thw	2	4	8	DCLK
VSYNC	Period Time	Tv	488	496	504	HSYNC
	Display Period	Tvdisp	480			HSYNC
	Back Porch	Tvbp	6	8	12	HSYNC
	Front Porch	Tvfp	6	8	12	HSYNC
	Pulse Width	Tvw	2	4	8	HSYNC

## 8. Backlight Characteristics

Item	Symbol	Min.	Typ.	Max.	Unit	Test Condition
Luminous Intensity for LCM and TP	-	640	800	-	cd/m <sup>2</sup>	+5V= 5V
Uniformity for LCM	-	80	-	-	%	
Lifetime	-	30,000	-	-	Hr	
Backlight Color	White					

## 9. Optical Characteristics

Item	Conditions		Min.	Typ.	Max.	Unit	Note
Viewing Angle (CR>10)	Horizontal	$\theta_L$	-	80	-	degree	(1),(2),(6)
		$\theta_R$	-	80	-		
	Vertical	$\theta_T$	-	80	-		
		$\theta_B$	-	80	-		
Contrast Ratio	Center		-	1200	-	-	(1),(3),(6)
Response Time	Rising + Falling			35	40	ms	(1),(4),(6)
CF Color Chromaticity (CIE1931)	Red x		Typ. -0.05	0.600	Typ. +0.05	-	(1), (6)
	Red y			0.370		-	
	Green x			0.340		-	
	Green y			0.600		-	
	Blue x			0.150		-	
	Blue y			0.115		-	
	White x			0.310		-	
	White y			0.329		-	
NTSC			-	50	-	%	(1),(6)

Note (1) Measurement Setup: The LCD module should be stabilized at given temp. 25°C for 15 minutes to avoid abrupt temperature change during measuring. In order to stabilize the luminance, the measurement should be executed after lighting backlight for 15 minutes in a windless room.

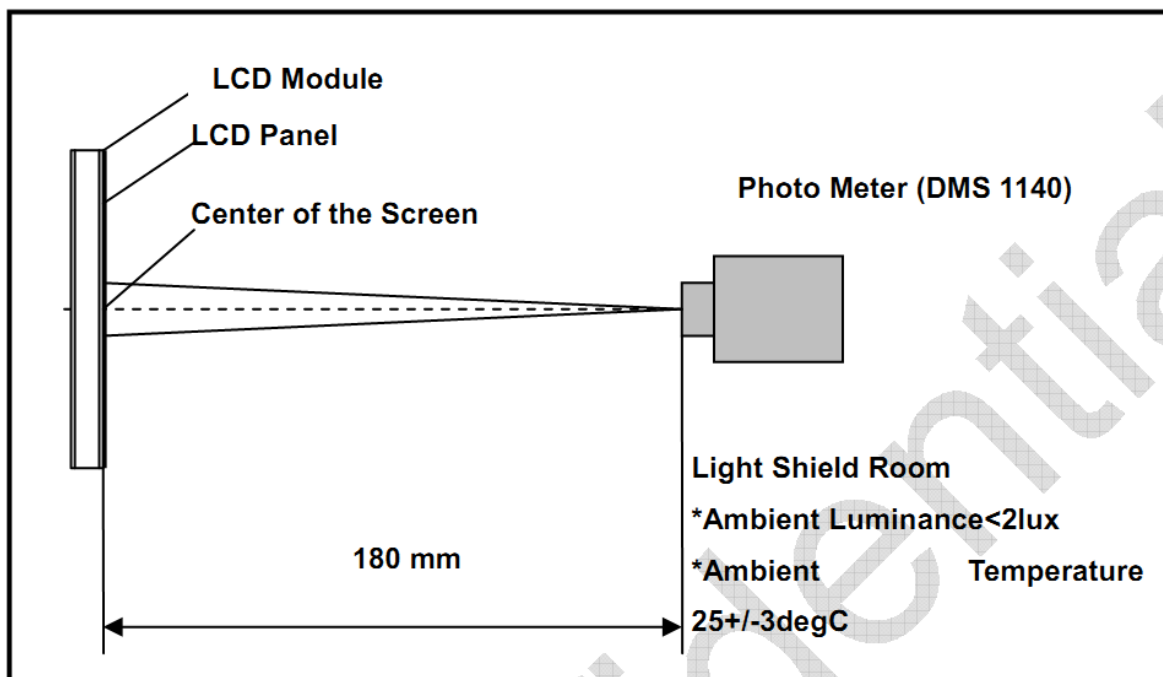

Note (2) Definition of Viewing Angle

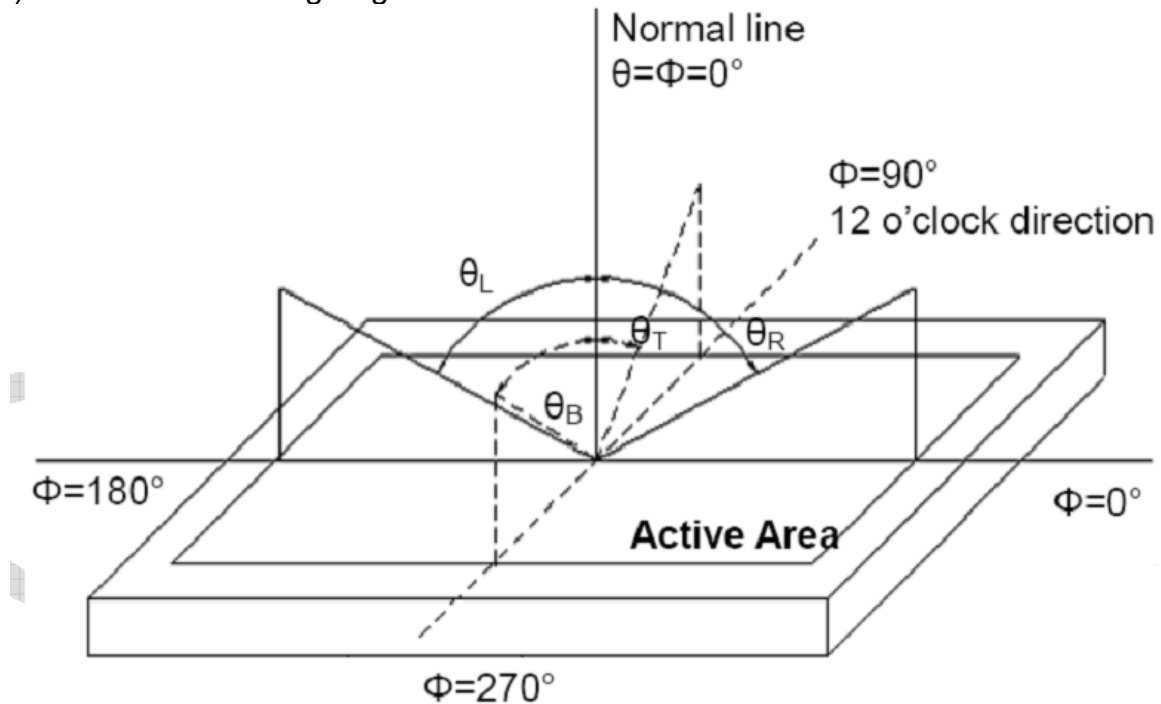

Note (3) Definition Of Contrast Ratio (CR)

The contrast ratio can be calculated by the following expression

$$\text{Contrast Ratio (CR)} = L_{63} / L_0$$

L63: Luminance of gray level 63, L0: Luminance of gray level 0

Note (4) Definition of response time

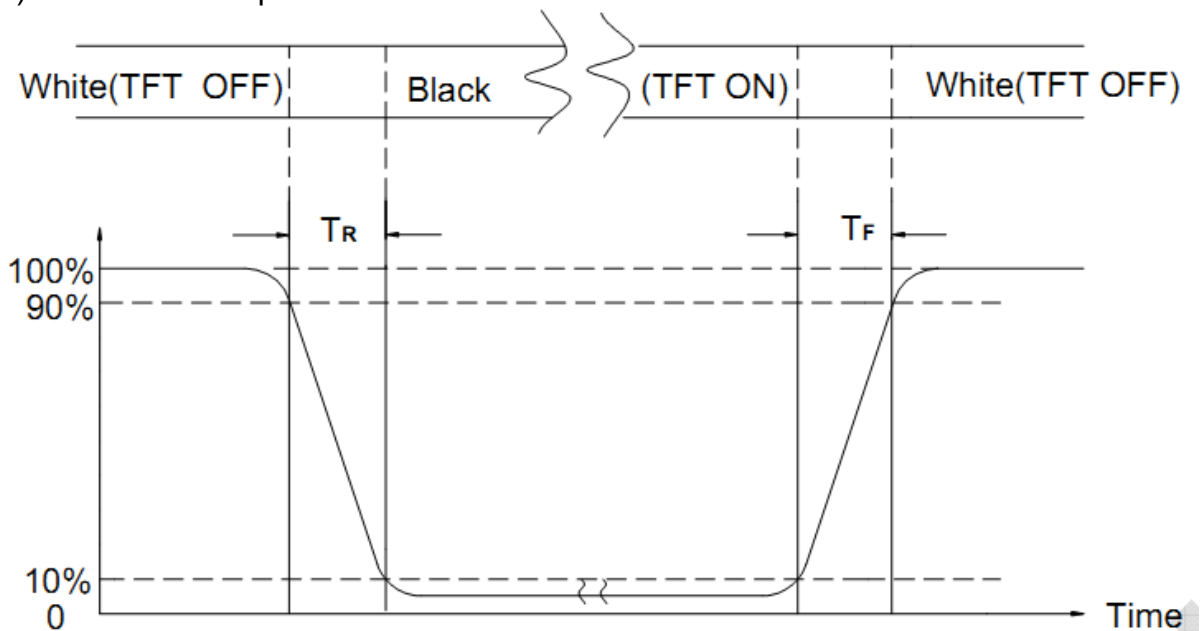

Note (5) Definition of Transmittance (Module is without signal input)

$$\text{Transmittance} = \text{Center Luminance of LCD} / \text{Center Luminance of Back Light} \times 100\%$$

Note (6) Definition of color chromaticity (CIE1931)

Color coordinates measured at the center point of LCD

## 10. Reliability Test Conditions and Methods

NO.	TEST ITEMS	TEST CONDITION	INSPECTION AFTER TEST
①	High Temperature Storage	85°C±2°C×96Hours	Inspection after 2~4hours storage at room temperature, the samples should be free from defects: 1, Air bubble in the LCD. 2, Seal leak. 3, Non-display. 4, Missing segments. 5, Glass crack. 6, Current IDD is twice higher than initial value. 7, The surface shall be free from damage. 8, The electric characteristic requirements shall be satisfied.
②	Low Temperature Storage	-30°C±2°C×96Hours	
③	High Temperature Operating	80°C±2°C×96Hours	
④	Low Temperature Operating	-30°C±2°C×96Hours	
⑤	Temperature Cycle(Storage)	$  \begin{array}{c}  -30^{\circ}\text{C} \longleftrightarrow 25^{\circ}\text{C} \longleftrightarrow 85^{\circ}\text{C} \\  (30\text{min}) \quad (5\text{min}) \quad (30\text{min}) \\  \longleftarrow \quad \quad \quad \longrightarrow \\  \text{1 cycle} \\  \text{Total 10cycle}  \end{array}  $	
⑥	Damp Proof Test (Storage)	50°C±5°C×90%RH×96Hours	
⑦	Vibration Test	Frequency:10Hz~55Hz~10Hz Amplitude:1.5MM X,Y,Z direction for total 3hours (packing condition test will be tested by a carton)	
⑧	Drooping Test	Drop to the ground from 1M height one time every side of carton. (packing condition test will be tested by a carton)	
⑨	ESD Test	Voltage:±8KV,R:330Ω,C:150PF,Air Mode,10times	

### REMARK:

- 1, The Test samples should be applied to only one test item.
- 2, Sample side for each test item is 5~10pcs.
- 3,For Damp Proof Test, Pure water(Resistance > 10MΩ)should be used.
- 4,In case of malfunction defect caused by ESD damage, if it would be recovered to normal state after resetting, it would be judge as a good part.
- 5, EL evaluation should be accepted from reliability test with humidity and temperature: Some defects such as black spot/blemish can happen by natural chemical reaction with humidity and Fluorescence EL has.
- 6, Failure Judgment Criterion: Basic Specification Electrical Characteristic, Mechanical Characteristic, Optical Characteristic.
- 7.①~ ⑥ test exclude Polaroid

## 11. Inspection Standard

### 11.1. QUALITY :

THE QUALITY OF GOODS SUPPLIED TO PURCHASER SHALL COME UP TO THE FOLLOWING STANDARD.

#### 11.1.1. INSPECTION TOOLS AND INSTRUMENTS

Vernier calipers, film scales, multimeter, magnifying eyepiece, ND5%, luminance meter and so on.

#### 11.1.2. THE METHOD OF PRESERVING GOODS

AFTER DELIVERY OF GOODS FROM AMSON TO PURCHASER. PURCHASER SHALL CONTROL THE LCM AT -10 TO 40 ,AND IT MIGHT BE DESIRABLE TO KEEP AT THE NORMAL ROOM TEMPERATURE AND HUMIDITY UNTIL INCOMING INSPECTION OR THROWING INTO PROCESS LINE.

#### 11.1.3. INCOMING INSPECTION

(A) THE METHOD OF INSPECTION

IF PURCHASER MAKE AN INCOMING INSPECTION , A SAMPLING PLAN SHALL BE APPLIED ON THE CONDITION THAT QUALITY OF ONE DELIVERY SHALL BE REGARDED AS ONE LOT.

(B) THE STANDARD OF QUALITY

ISO-2859-1 (SAME AS MIL-STD-105E ) ,LEVEL:II

CLASS	AQL(%)
CRITICAL	0.4 %
MAJOR	0.65 %
MINOR	1.5 %

EVERY ITEM SHALL BE INSPECTED ACCORDING TO THE CLASS.

(C) MEASURE

IF AS THE RESULT OF ABOVE RECEIVING INSPECTION , A LOT OUT IS DISCOVERED. PURCHASER SHALL BE INFORM SELLER OF IT WITHIN SEVEN DAYS. BUT FIRST SHIPMENT WITHIN FOURTEEN DAYS.

#### 11.1.4. WARRANTY POLICY

AMSON WILL PROVIDE ONE-YEAR WARRANTY FOR THE PRODUCTS ONLY IF UNDER SPECIFICATION OPERATING CONDITIONS. AMSON WILL REPLACE NEW PRODUCTS FOR THESE DEFECT PRODUCTS WHICH UNDER WARRANTY PERIOD AND BELONG TO THE RESPONSIBILITY OF AMSON.

## 11.2. CHECKING CONDITION

11.2.1.CHECKING DIRECTION SHALL BE IN THE 45 DEGREE AREA TO FACE THE SAMPLE.

11.2.2.CHECKER SHALL SEE OVER 300±25 mm. WITH BARE EYES FAR FROM SAMPLE

11.2.3.Ambient Illumination:

0 ~30 Lux for functional inspection

500 ~ 1200 Lux for external appearance inspection.

11.2.4. TEST AREA:

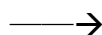

11.2.5. Inspection should be carried out with rope electrostatic ring and static finger cover (both hands except small fingers must be worn)

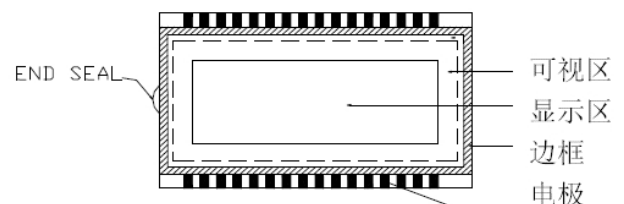

**11.2.6.** The inspector may make a visual inspection or a comparative examination with a film ruler and a magnifying eyepiece. Individual defects shall be determined according to the limited samples.

**11.2.7.** Functional testing uses electrical testing fixtures or test fixtures required by customers.

**11.2.8.** the ion fan should be used when testing.

### 11.2.9. the principle of judgment

11.3.1 If the defect outside the visual area does not affect the assembly and display, it will be judged as a good product.

#### 11.3.2 Poor definition

Pixel:

A combination of three sub-pixels (Red + Green + Blue).

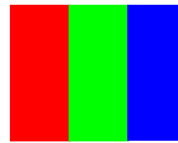

**Dot:**

Any of the sub-pixels (Red or Green or Blue).

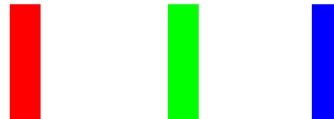

#### **Bright and dark dots:**

A point pixel (sub-pixel: R, G, B pixels) is lit or turned off during the display function test.

#### **Highlights:**

Usually considered to be shown on a black screen.

#### **Dark spots:**

They are generally considered to be shown on R, G, B solid colors or white images.

#### **Neighborhood:**

Two or three adjacent point pixels (dot: sub-pixel) connected together (R, G or G, B or B, R or RGB).

11.3. INSPECTION PLAN :

CLASS	ITEM	JUDGEMENT	CLASS
PACKING & INDICATE	1. OUTSIDE AND INSIDE PACKAGE	"MODEL NO." , "LOT NO." AND "QUANTITY" SHOULD INDICATE ON THE PACKAGE.	Minor
	2. MODEL MIXED AND QUANTITY	OTHER MODEL MIXED.....REJECTED QUANTITY SHORT OR OVER.....REJECTED	Critical
	3. PRODUCT INDICATION	"MODEL NO." SHOULD INDICATE ON THE PRODUCT	Major
ASSEMBLY	4. DIMENSION, LCD GLASS SCRATCH AND SCRIBE DEFECT.	ACCORDING TO SPECIFICATION OR DRAWING.	Major
APPEARANCE	5. VIEWING AREA	POLARIZER EDGE OR LCD'S SEALING LINE IS VISABLE IN THE VIEWING AREA .....REJECTED	Minor
	6. BLEMISH · BLACK SPOT · WHITE SPOT IN THE LCD AND LCD GLASS CRACKS	ACCORDING TO STANDARD OF VISUAL INSPECTION(INSIDE VIEWING AREA)	Minor
	7. BLEMISH · BLACK SPOT WHITE SPOT AND SCRATCH ON THE POLARIZER	ACCORDING TO STANDARD OF VISUAL INSPECTION(INSIDE VIEWING AREA)	Minor
	8. BUBBLE IN POLARIZER	ACCORDING TO STANDARD OF VISUAL INSPECTION(INSIDE VIEWING AREA)	Minor
	9. LCD'S RAINBOW COLOR	STRONG DEVIATION COLOR ( OR NEWTON RING) OF LCD.....REJECTED. OR ACCORDING TO LIMITED SAMPLE ( IF NEEDED, AND INSIDE VIEWING AREA )	Minor
ELECTRICAL	10. ELECTRICAL AND OPTICAL CHARACTERISTICS ( CONTRAST· VOP · CHROMATICITY ... ETC )	ACCORDING TO SPECIFICATION OR DRAWING . ( INSIDE VIEWING AREA )	Critical
	11.MISSING LINE	MISSING DOT · LINE · CHARACTER .....REJECTED	Critical
	12.SHORT CIRCUIT· WRONG PATTERN DISPLAY	NO DISPLAY · WRONG PATTERN DISPLAY · CURRENT CONSUMPTION OUT OF SPECIFICATION..... REJECTED	Critical
	13. DOT DEFECT (FOR COLOR AND TFT)	ACCORDING TO STANDARD OF VISUAL INSPECTION	Minor

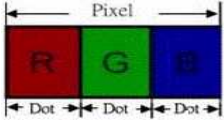

## 11.4. STANDARD OF VISUAL INSPECTION

NO.	CLASS	ITEM	JUDGEMENT									
11.4.1	MINOR	BLACK AND WHITE SPOT FOREIGN MATERIEL DUST IN THE CELL BLEMISH SCRATCH	(A) ROUND TYPE: <span style="float: right;">unit: mm</span> <table border="1" style="width: 100%; border-collapse: collapse;"> <thead> <tr> <th>DIAMETER (mm.)</th> <th>ACCEPTABLE Q' TY</th> </tr> </thead> <tbody> <tr> <td style="text-align: center;"><math>\varnothing \leq 0.1</math></td> <td>Disregard(interval<math>\geq</math>1mm)</td> </tr> <tr> <td style="text-align: center;"><math>0.1 &lt; \varnothing \leq 0.25</math></td> <td>2 (Distance <math>\geq</math> 5mm)</td> </tr> <tr> <td style="text-align: center;"><math>0.25 &lt; \varnothing</math></td> <td style="text-align: center;">0</td> </tr> </tbody> </table> <p style="text-align: center;">NOTE: <math>\varnothing = (\text{LENGTH} * \text{WIDTH}) / 2</math></p>	DIAMETER (mm.)	ACCEPTABLE Q' TY	$\varnothing \leq 0.1$	Disregard(interval $\geq$ 1mm)	$0.1 < \varnothing \leq 0.25$	2 (Distance $\geq$ 5mm)	$0.25 < \varnothing$	0	
			DIAMETER (mm.)	ACCEPTABLE Q' TY								
$\varnothing \leq 0.1$	Disregard(interval $\geq$ 1mm)											
$0.1 < \varnothing \leq 0.25$	2 (Distance $\geq$ 5mm)											
$0.25 < \varnothing$	0											
(S) ROUND TYPE: <span style="float: right;">unit: mm</span> <table border="1" style="width: 100%; border-collapse: collapse;"> <thead> <tr> <th>LENGTH</th> <th>WIDTH</th> <th>ACCEPTABLE QTY</th> </tr> </thead> <tbody> <tr> <td style="text-align: center;">.....</td> <td style="text-align: center;"><math>W \leq 0.03</math></td> <td style="text-align: center;">Disregard</td> </tr> <tr> <td style="text-align: center;"><math>L \leq 5.0</math></td> <td style="text-align: center;"><math>0.03 &lt; W \leq 0.07</math></td> <td style="text-align: center;">3 (Distanced <math>\geq</math> 5mm)</td> </tr> <tr> <td style="text-align: center;">.....</td> <td style="text-align: center;"><math>0.07 &lt; W</math></td> <td style="text-align: center;">FOLLOW ROUND TYPE</td> </tr> </tbody> </table> <p style="text-align: center;">NOTE: <math>\varnothing = (\text{LENGTH} * \text{WIDTH}) / 2</math></p>	LENGTH	WIDTH	ACCEPTABLE QTY	.....	$W \leq 0.03$	Disregard	$L \leq 5.0$	$0.03 < W \leq 0.07$	3 (Distanced $\geq$ 5mm)	.....	$0.07 < W$	FOLLOW ROUND TYPE
LENGTH	WIDTH	ACCEPTABLE QTY										
.....	$W \leq 0.03$	Disregard										
$L \leq 5.0$	$0.03 < W \leq 0.07$	3 (Distanced $\geq$ 5mm)										
.....	$0.07 < W$	FOLLOW ROUND TYPE										
11.4.2	MINOR	BUBBLE IN POLARIZER DENT ON POLARIZER	unit: mm. <table border="1" style="width: 100%; border-collapse: collapse;"> <thead> <tr> <th>DIAMETER</th> <th>ACCEPTABLE Q' TY</th> </tr> </thead> <tbody> <tr> <td style="text-align: center;"><math>\varnothing &lt; 0.1</math></td> <td>Disregard(interval<math>\geq</math>1mm)</td> </tr> <tr> <td style="text-align: center;"><math>0.1 &lt; \varnothing \leq 0.3</math></td> <td>2(Distance<math>\geq</math> 5mm)</td> </tr> <tr> <td style="text-align: center;"><math>0.3 &lt; \varnothing</math></td> <td style="text-align: center;">0</td> </tr> </tbody> </table>	DIAMETER	ACCEPTABLE Q' TY	$\varnothing < 0.1$	Disregard(interval $\geq$ 1mm)	$0.1 < \varnothing \leq 0.3$	2(Distance $\geq$ 5mm)	$0.3 < \varnothing$	0	
DIAMETER	ACCEPTABLE Q' TY											
$\varnothing < 0.1$	Disregard(interval $\geq$ 1mm)											
$0.1 < \varnothing \leq 0.3$	2(Distance $\geq$ 5mm)											
$0.3 < \varnothing$	0											
11.4.3	MINOR	Dot Defect	<table border="1" style="width: 100%; border-collapse: collapse;"> <thead> <tr> <th>Items</th> <th>ACC. Q' TY</th> </tr> </thead> <tbody> <tr> <td style="text-align: center;">Bright dot</td> <td style="text-align: center;"><math>N \leq 1</math></td> </tr> <tr> <td style="text-align: center;">Dark dot</td> <td style="text-align: center;"><math>N \leq 2</math> (Distance <math>\geq</math> 5mm)</td> </tr> </tbody> </table> <p>Pixel Define :</p>  <p>Note:</p> <ol style="list-style-type: none"> <li>The definition of dot: The size of a defective dot over 1 of whole dot is regarded as one defective dot. Definition:<math>&lt;1/2</math> dot and visible by 5% ND filter</li> <li>Bright dot: Dots appear bright and unchanged in size which LCD panel is displaying under black pattern.</li> <li>Dark dot: Dots appear dark and unchanged in size in which LCD panel is displaying under pure Red, Green, Blue pattern.</li> </ol>	Items	ACC. Q' TY	Bright dot	$N \leq 1$	Dark dot	$N \leq 2$ (Distance $\geq$ 5mm)			
Items	ACC. Q' TY											
Bright dot	$N \leq 1$											
Dark dot	$N \leq 2$ (Distance $\geq$ 5mm)											
11.4.3.1	MINOR	Mura	Not visible through 5% ND filter in 50% gray or judge by limit sample if necessary									

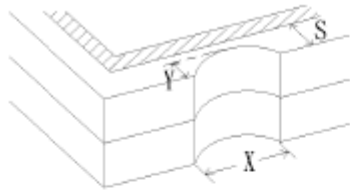
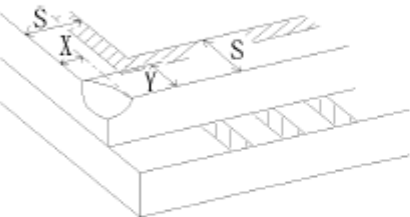
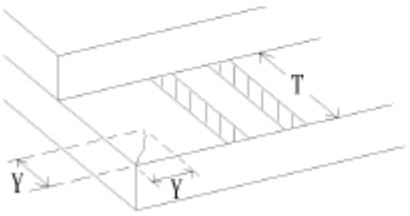
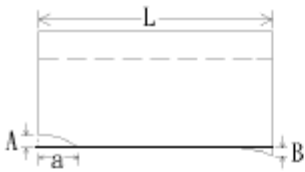
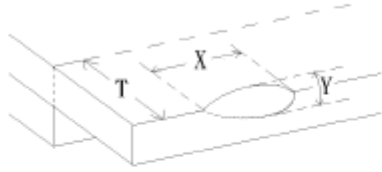
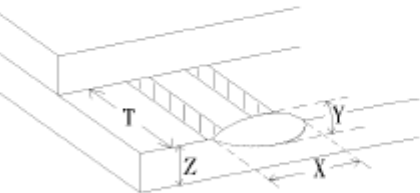
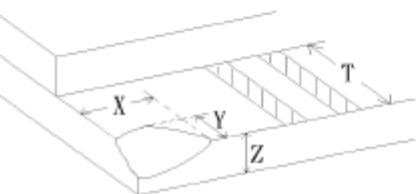
NO.	CLASS	ITEM	JUDGEMENT
11.4.4	MINOR	LCD GLASS CHIPPING	 $Y > S$ Reject
11.4.5	MINOR	LCD GLASS CHIPPING	 $X \text{ or } Y > S$ Reject
11.4.6	MAJOR	LCD GLASS GLASS CRACK	 $Y > (1/2) T$ Reject
11.4.7	MAJOR	LCD GLASS SCRIBE DEFECT	 <ol style="list-style-type: none"> <li><math>a &gt; L/3</math>, <math>A &gt; 1.5\text{mm}</math>. Reject</li> <li>B : ACCORDING TO DIMENSION</li> </ol>
11.4.8	MINOR	LCD GLASS CHIPPING ( ON THE TERMINAL AREA )	 $\Phi = (x+y)/2 > 2.5 \text{ mm}$ Reject
11.4.9	MINOR	LCD GLASS CHIPPING ( ON THE TERMINAL SURFACE )	 $Y > (1/3) T$ Reject
11.4.10	MINOR	LCD GLASS CHIPPING	 $Y > T$ Reject

## 12. Handling Precautions

### 12.1 Mounting method

The LCD panel of AMSON TFT module consists of two thin glass plates with polarizers which easily be damaged. And since the module is so constructed as to be fixed by utilizing fitting holes in the printed circuit board.

Extreme care should be needed when handling the LCD modules.

### 12.2 Caution of LCD handling and cleaning

When cleaning the display surface, Use soft cloth with solvent

[Recommended below] and wipe lightly

- Isopropyl alcohol
- Ethyl alcohol

Do not wipe the display surface with dry or hard materials that will damage the polarizer surface.

Do not use the following solvent:

- Water
- Aromatics

Do not wipe ITO pad area with the dry or hard materials that will damage the ITO patterns

Do not use the following solvent on the pad or prevent it from being contaminated:

- Soldering flux
- Chlorine (Cl) , Sulfur (S)

If goods were sent without being silicon coated on the pad, ITO patterns could be damaged due to the corrosion as time goes on.

If ITO corrosion happens by miss-handling or using some materials such as Chlorine (Cl), Sulfur (S) from customer, Responsibility is on customer.

### 12.3 Caution against static charge

The LCD module uses C-MOS LSI drivers, so we recommend that you:

Connect any unused input terminal to power or ground, do not input any signals before power is turned on, and ground your body, work/assembly areas, and assembly equipment to protect against static electricity.

### 12.4 packing

- Module employs LCD elements and must be treated as such.
- Avoid intense shock and falls from a height.
- To prevent modules from degradation, do not operate or store them exposed direct to sunshine or high temperature/humidity

### 12.5 Caution for operation

- It is an indispensable condition to drive LCD's within the specified voltage limit since the higher voltage than the limit causes the shorter LCD life.
- An electrochemical reaction due to direct current causes LCD's undesirable deterioration, so that the use of direct current drive should be avoided.
- Response time will be extremely delayed at lower temperature than the operating temperature range and on the other hand at higher temperature LCD's show dark color in them. However those phenomena do not mean malfunction or out of order with LCD's, which will come back in the specified operation temperature.
- If the display area is pushed hard during operation, some font will be abnormally displayed but it resumes normal condition after turning off once.
- Slight dew depositing on terminals is a cause for electro-chemical reaction resulting in terminal open circuit.

Usage under the maximum operating temperature, 50%Rh or less is required.

## 12.6 storing

In the case of storing for a long period of time for instance, for years for the purpose or replacement use, the following ways are recommended.

- Storage in a polyethylene bag with the opening sealed so as not to enter fresh air outside in it. And with no desiccant.
- Placing in a dark place where neither exposure to direct sunlight nor light's keeping the storage temperature range.
- Storing with no touch on polarizer surface by the anything else.  
[It is recommended to store them as they have been contained in the inner container at the time of delivery from us.]

## 12.7 Safety

- It is recommendable to crash damaged or unnecessary LCD's into pieces and wash off liquid crystal by either of solvents such as acetone and ethanol, which should be burned up later.
- When any liquid leaked out of a damaged glass cell comes in contact with your hands, please wash it off well with soap and water.

## 13. Precaution for Use

### 13.1

A limit sample should be provided by the both parties on an occasion when the both parties agreed its necessity. Judgment by a limit sample shall take effect after the limit sample has been established and confirmed by the both parties.

### 13.2

On the following occasions, the handing of problem should be decided through discussion and agreement between responsible of the both parties.

- When a question is arisen in this specification.
- When a new problem is arisen this is not specified in this specification.
- When an inspection specifications change or operating condition change in customer is reported to AMSON TFT and some problem is arisen in this specification due to the change.
- When a new problem is arisen at the customer's operating set for sample evaluation in the customer site.

## 14. Packing Method

TBD