



# Specification for Approval

Customer: \_\_\_\_\_

Model Name: \_\_\_\_\_

Supplier Approval			Customer approval
R&D Designed	R&D Approved	QC Approved	
Sam	Peng Jun		



## Revision Record

REV NO.	REV DATE	CONTENTS	Note
A	2024-10-30	New Issue	

## Table of Contents

List	Description	Page No.
	Cover	1
	Revision Record	2
	Table of Contents	3
1	Scope	4
2	General Information	4
3	External Dimensions	6
4	Interface Description	7
5	Absolute Maximum Ratings	8
6	Electrical Characteristics	8
7	Block Diagram	9
8	Backlight Characteristics	10
9	Optical Characteristics	11
10	Reliability Test Conditions and Methods	13
11	Handling Precautions	18
12	Precaution for Use	19
13	Packing Method	20

## 1. Scope

Smart Graphic TFT Module Plus is an unique TFT LCD module which builds graphic and character inside. It provides user to present customized & full color graphics or characters without any SOC or IPC system. In addition, user can update or upload his graphics or characters via Micro USB or Micro SD slot by himself.

- Friendly and Free Development Environment
- Multi-layer design
- Advanced GUI function
- Easy Touch Effects
- Easy and fast update image with Micro USB or Micro SD
- Single Operation Voltage +5-26V
- Serial Communication: UART TTL

## 2. General Information

ITEM	STANDARD VALUES	UNITS
LCD Type	7.0" TFT	--
Dot Arrangement	800(RGB) x 480	Dots
Color Filter Array	65K(65536) RGB	--
Display Mode	TN/Transmission / Normally Black	--
Gray Scale Inversion Direction	70/70/50/70	--
Eyes Viewing Direction	12 o'clock	--
Module PCB Size	185(W)×110(H)×1.6(T)	mm
Module LCD Size	165.75(W)×100(H)×6.9(T)	mm
Active Area	154.08(W)× 85.92(H)	mm
Back Light	27White LED	--
Touch Panel Optional	RTP	
Communication Protocol	UART Transmission Rate 115200,8,N,1	Bps
Micro SD Slot	Recommend 4G (32G max)	
Flash Memory	1	G
RAM	1.4	M
Weight	TBD	g

## RTP

ITEM	STANDARD VALUES	UNITS
RTP TYPE	Film + Glass + FPC	--
Surface Treatment	3H	--
Transmittance	$\geq 78\%$	--
The cover hardness	3H	--
RTP size	164.4 (W) $\times$ 98.9 (H) $\times$ 1.1(T)	mm
RTP Active area	155.2(W) $\times$ 88.24 (H)	mm
Response time	$\leq 10\text{ms}$	ms
Insulation resistance	$> 10\text{M}\Omega$	$\text{M}\Omega$
Resistance	X: $200\Omega \sim 1100\Omega$ Y: $200\Omega \sim 1100\Omega$	$\Omega$

## 3. External Dimensions

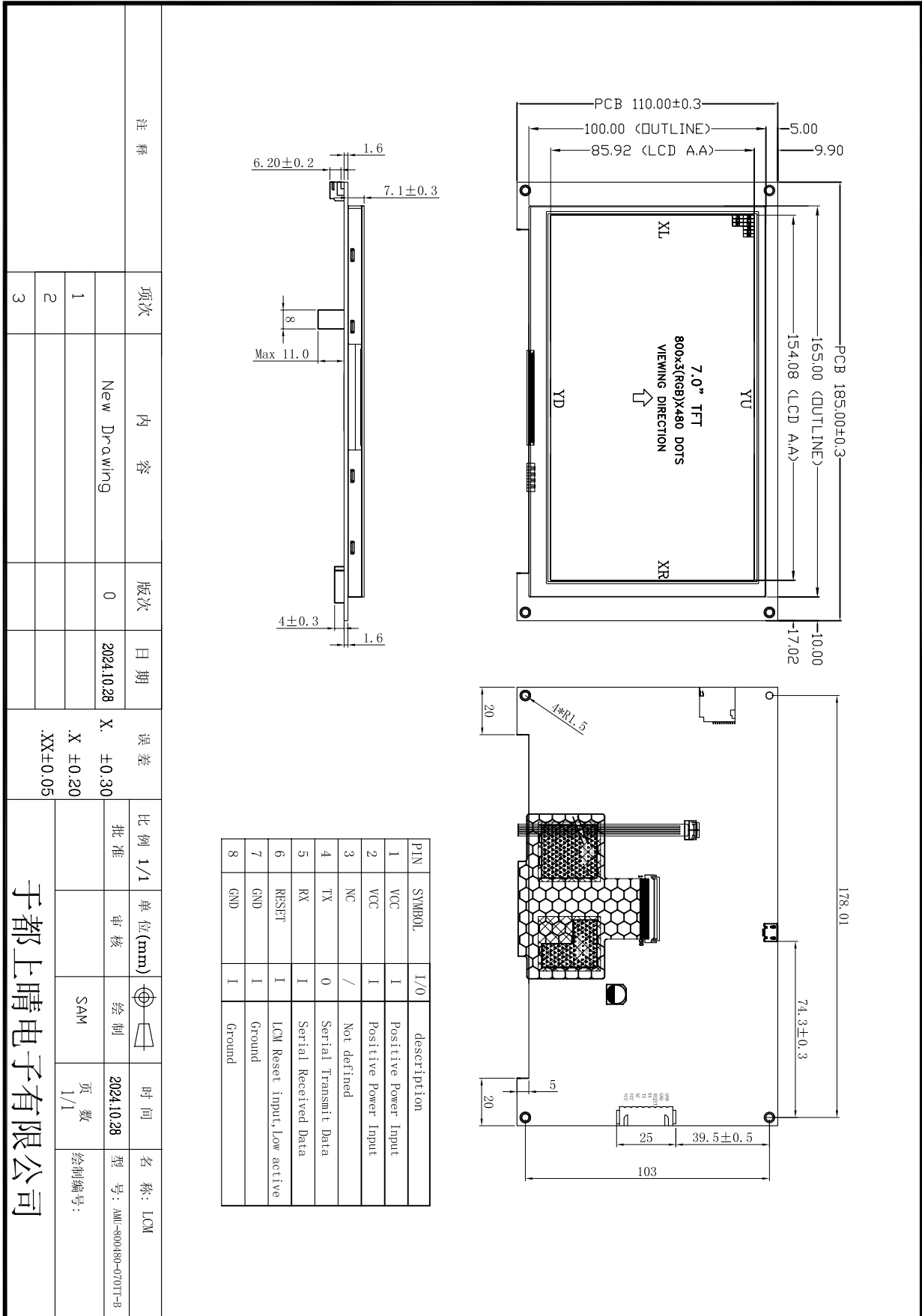

于都上晴电子有限公司

项次	内容	版次	日期	误差	比例	单位	审核	时间	名称
1	New Drawing	0	2024.10.28	X. ±0.30	1/1	(mm)	SAM	2024.10.28	型号: AMU-800480-070TT-B
2				.X ±0.20					绘制编号:
3				.XX±0.05					

## 4. Interface Description

### XH2.54-8P

PIN No.	PIN Name	Level	DESCRIPTION
1	VCC	I	Positive Power Input
2	VCC	I	Positive Power Input
3	NC	-	Not defined
4	TX	O	Serial Transmit Data
5	RX	I	Serial Received Data
6	RESET	I	LCM Reset input,Low active
7	GND	I	Power Supply Ground.
8	GND	I	Power Supply Ground.

## 5. Absolute Maximum Ratings

Item	Symbol	Min.	Max.	Unit
Supply Voltage For Analog	$V_{DD}$	-0.3	26.0	V
Input Voltage	$V_{IN}$	-0.3	$V_{DD}$	V
Operating Temperature	$T_{OP}$	-20	70	°C
Storage Temperature	$T_{ST}$	-30	85	°C
Storage Humidity	HD	--	90	%RH

## 6. DC Characteristics

Item	Symbol	Min.	Typ.	Max.	Unit
Supply Voltage For Analog	$V_{IN}$	4.5	5.0	26	V
Supply Voltage For Logic	$V_{DD}$	2.7	3.3	3.6	V
GPIO Input High Voltage	$V_{IH}$	$0.7V_{DD}$	--	$V_{DD}$	V
GPIO Input Low Voltage	$V_{IL}$	$V_{SS}$	--	$0.3V_{DD}$	V
GPIO Output High Voltage	$V_{OH}$	$V_{DD}-0.6$	--	$V_{DD}$	V
GPIO Output Low Voltage	$V_{OL}$	$V_{SS}$	--	0.4	V
Supply Analog Current ( $V_{IN}=5V$ )	$I_{IN}$	--	550	-	mA



## 7. Block Diagram

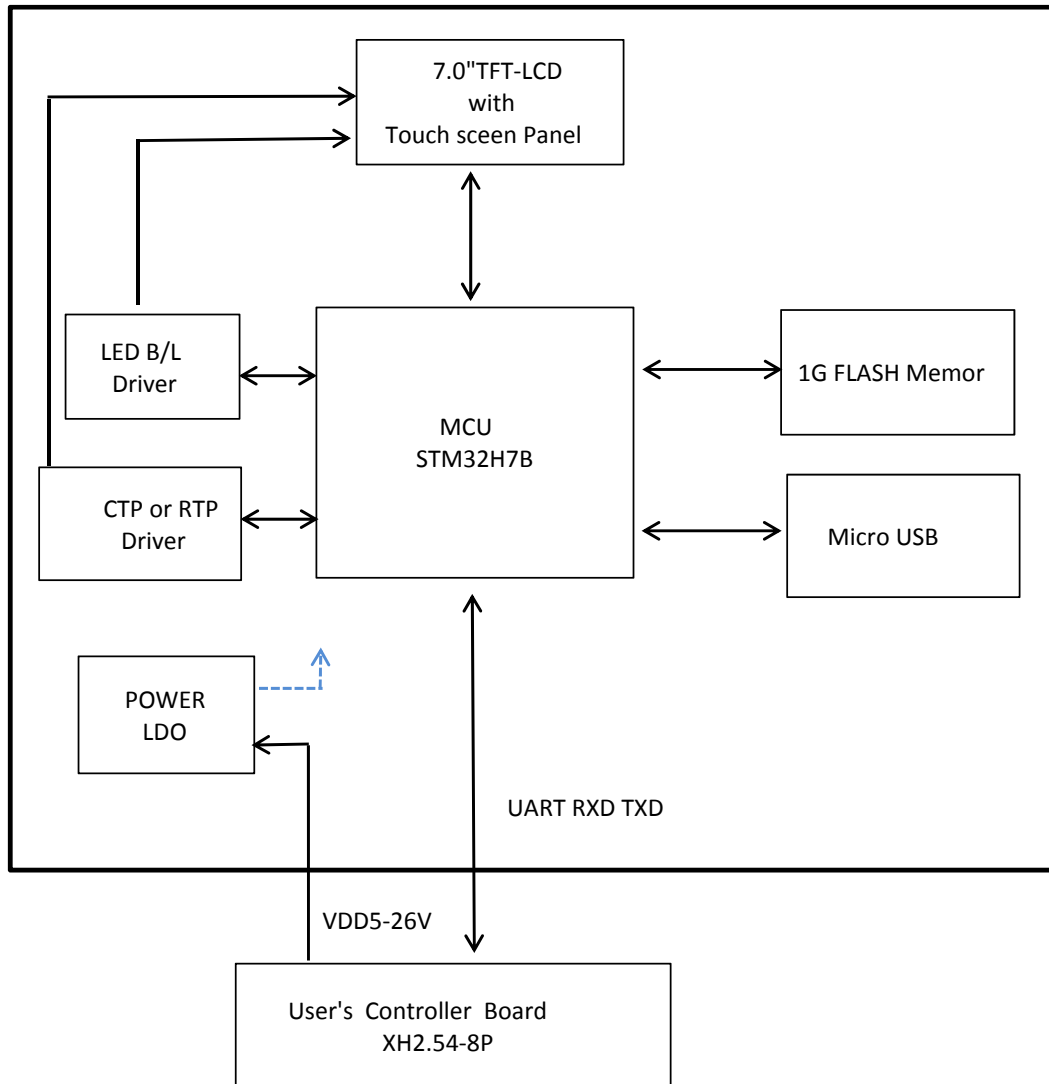

## 8. Backlight Characteristics

Item	Symbol	MIN	TYP	MAX	UNIT	Test Condition
Supply Voltage	Vf	-	9.6	-	V	
Supply Current	If	-	180	-	mA	
Luminous Intensity for LCM	-	300	350	-	Cd/m <sup>2</sup>	
Uniformity for LCM	-	80	-	-	%	
Life Time	-	50000-		-	Hr	
Backlight Color	White					

## 9. Optical Characteristics

Item	Conditions	Min.	Typ.	Max.	Unit	Note	
Viewing Angle (CR>10)	Horizontal	$\theta_L$	60	70	-	degree	Viewing Angle (CR>10)
		$\theta_R$	60	70	-		
	Vertical	$\theta_T$	40	50	-		
		$\theta_B$	60	70	-		
Contrast Ratio	Center	400	500	-	-	(1),(3),(6)	
Response Time	$T_R+T_F$		10	20	ms	(1),(4),(6)	
CF Color Chromaticity (CIE1931)	Red x	+/-0.02	TBD	+/-0.02		(1), (6)	
	Red y		TBD				
	Green x		TBD				
	Green y		TBD				
	Blue x		TBD				
	Blue y		TBD				
	White x		TBD				
	White y		TBD				
Color Gamut	CIE1931		50	-	%	(1),(6)	

Note (1) Measurement Setup: The LCD module should be stabilized at given temp. 25°C for 15 minutes to avoid abrupt temperature change during measuring. In order to stabilize the luminance, the measurement should be executed after lighting backlight for 15 minutes in a windless room.

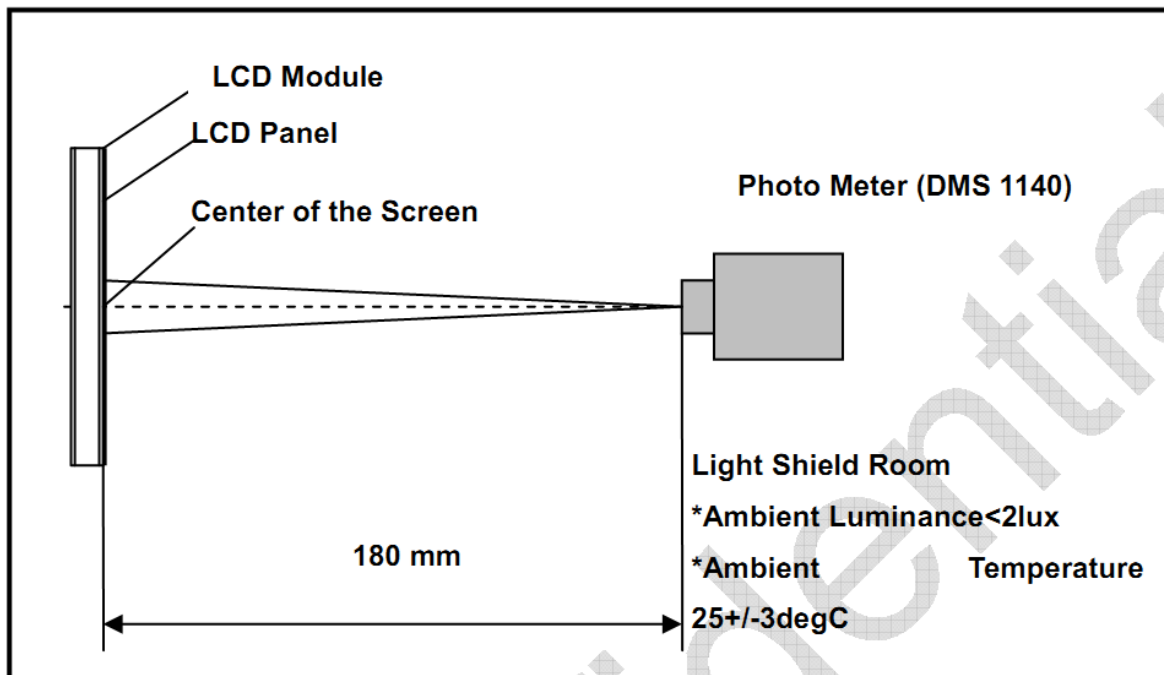

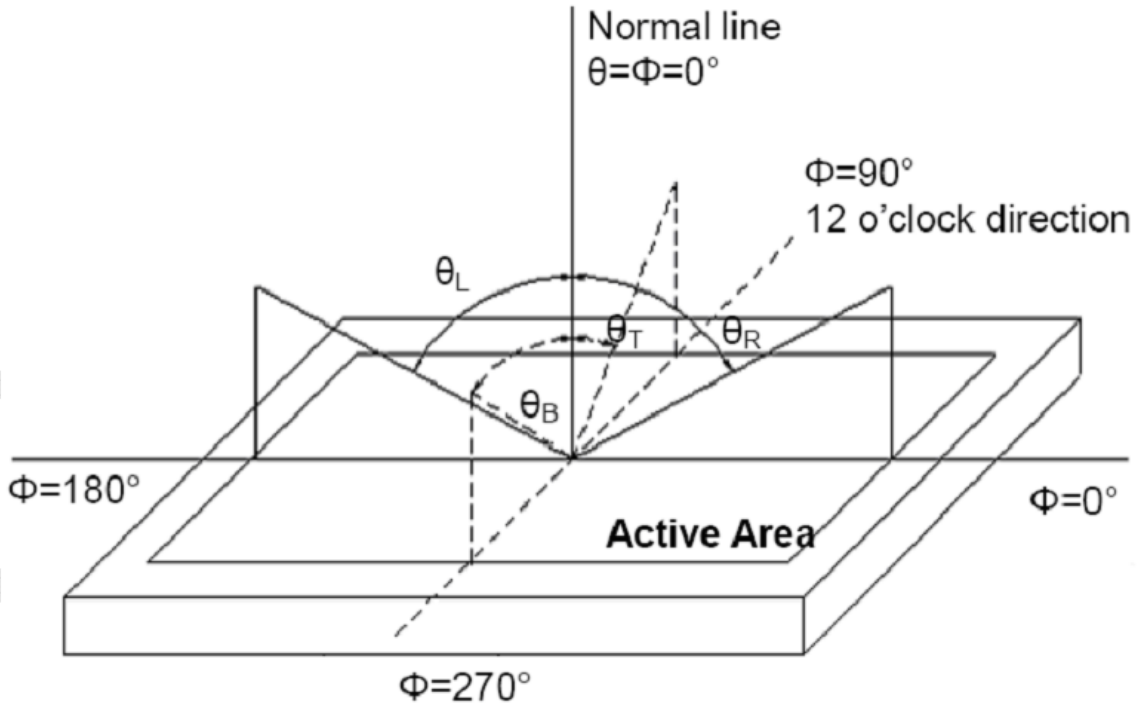

Note (3) Definition Of Contrast Ratio (CR)

The contrast ratio can be calculated by the following expression

$$\text{Contrast Ratio (CR)} = L63 / L0$$

L63: Luminance of gray level 63, L0: Luminance of gray level 0

Note (4) Definition of response time

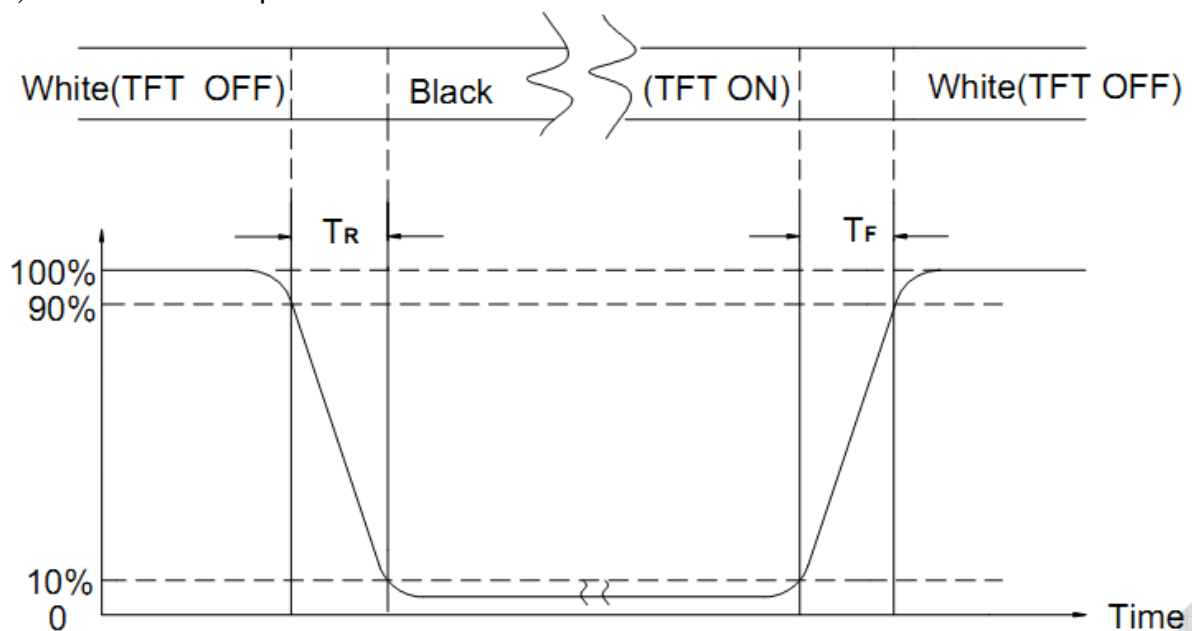

Note (5) Definition of Transmittance (Module is without signal input)

$$\text{Transmittance} = \text{Center Luminance of LCD} / \text{Center Luminance of Back Light} \times 100\%$$

Note (6) Definition of color chromaticity (CIE1931)

Color coordinates measured at the center point of LCD

**10. Reliability Test Conditions and Methods**

NO.	TEST ITEMS	TEST CONDITION	INSPECTION AFTER TEST
①	High Temperature Storage	80°C±3°C×96Hours	Inspection after 2~4hours storage at room temperature, the samples should be free from defects: 1, Air bubble in the LCD. 2, Seal leak. 3, Non-display. 4, Missing segments. 5, Glass crack. 6, Current IDD is twice higher than initial value. 7, The surface shall be free from damage. 8, The electric characteristic requirements shall be satisfied.
②	Low Temperature Storage	-30°C±3°C×96Hours	
③	High Temperature Operating	70°C±3°C×96Hours	
④	Low Temperature Operating	-20°C±3°C×96Hours	
⑤	Temperature Cycle(Storage)	$  \begin{array}{ccccc}  -20^{\circ}\text{C} & \longleftrightarrow & 25^{\circ}\text{C} & \longleftrightarrow & 70^{\circ}\text{C} \\  (30\text{min}) & & (5\text{min}) & & (30\text{min}) \\  & \longleftarrow & & \longrightarrow & \\  & \text{1 cycle} & & & \\  & \text{Total 10cycle} & & &   \end{array}  $	
⑥	Damp Proof Test (Storage)	50°C±5°C×90%RH×96Hours	
⑦	Vibration Test	Frequency:10Hz~55Hz~10Hz Amplitude:1.5M X,Y,Z direction for total 3hours (Packing Condition)	
⑧	Drooping Test	Drop to the ground from 1M height one time every side of carton. (Packing Condition)	
⑨	ESD Test	Voltage:±8KV,R:330Ω,C:150PF,Air Mode,10times	

**REMARK:**

- The Test samples should be applied to only one test item.
- Sample side for each test item is 5~10pcs.
- For Damp Proof Test, Pure water(Resistance > 10MΩ)should be used.
- In case of malfunction defect caused by ESD damage, if it would be recovered to normal state after resetting, it would be judge as a good part.
- EL evaluation should be accepted from reliability test with humidity and temperature: Some defects such as black spot/blemish can happen by natural chemical reaction with humidity and Fluorescence EL has.
- Failure Judgment Criterion: Basic Specification Electrical Characteristic, Mechanical Characteristic, Optical Characteristic.

## 10.1 Quality

### 10.1.3 Sampling Plan

According to GB/T 2828-2003 ; , normal inspection, Class II

AQL:

Major defect	Minor defect
0.65	1.5

LCD: Liquid Crystal Display , TP: Touch Panel , LCM: Liquid Crystal Module

No	Items to be inspected	Criteria	Classification of defects
1	Functional defects	1) No display, Open or miss line 2) Display abnormally, Short 3) Backlight no lighting, abnormal lighting. 4) TP no function	Major
2	Missing	Missing component	
3	Outline dimension	Overall outline dimension beyond the drawing is not allowed	
4	Color tone	Color unevenness, refer to limited sample	Minor
5	Soldering appearance	Good soldering , Peeling off is not allowed.	
6	LCD/Polarizer/TP	Black/White spot/line, scratch, crack, etc.	

### 11.1.4 Criteria (Visual)

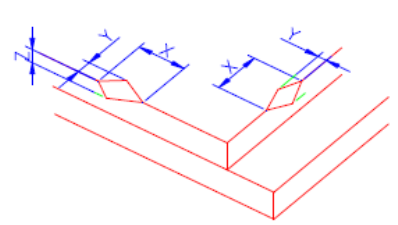
Number	Items	Criteria(mm)			
1.0 LCD Crack/Broken	(1) The edge of LCD broken				
NOTE:		<table border="1" style="margin-left: auto; margin-right: auto;"> <tr> <td style="width: 30px; text-align: center;">X</td> <td style="width: 30px; text-align: center;">Y</td> <td style="width: 30px; text-align: center;">Z</td> </tr> </table>	X	Y	Z
X	Y	Z			

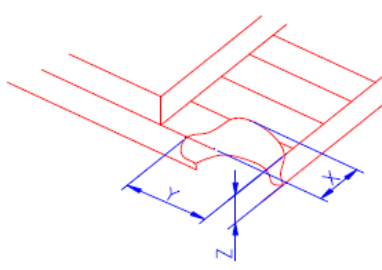
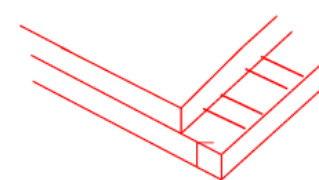
X: Length Y: Width Z: Height L: Length of ITO, T: Height of LCD		$\leq 3.0\text{mm}$	<Inner border line of the seal	$\leq T$						
	(2) LCD corner broken	 <table border="1" data-bbox="925 649 1340 761"> <thead> <tr> <th>X</th> <th>Y</th> <th>Z</th> </tr> </thead> <tbody> <tr> <td><math>\leq 3.0\text{mm}</math></td> <td><math>\leq L</math></td> <td><math>\leq T</math></td> </tr> </tbody> </table>			X	Y	Z	$\leq 3.0\text{mm}$	$\leq L$	$\leq T$
	X	Y	Z							
$\leq 3.0\text{mm}$	$\leq L$	$\leq T$								
(3) LCD crack	 <p style="text-align: center;">Crack Not allowed</p>									

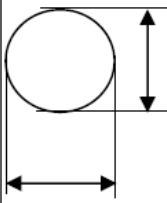
Number	Items	Criteria (mm)																							
2.0	Spot defect  $\Phi=(X+Y)/2$	① light dot ( LCD/TP/Polarizer black/white spot , light dot, pinhole, dent, stain ) <table border="1" data-bbox="446 392 1220 750"> <thead> <tr> <th rowspan="2">Zone Size (mm)</th> <th colspan="3">Acceptable Qty</th> </tr> <tr> <th>A</th> <th>B</th> <th>C</th> </tr> </thead> <tbody> <tr> <td><math>\Phi \leq 0.10</math></td> <td colspan="3">Ignore</td> </tr> <tr> <td><math>0.10 &lt; \Phi \leq 0.15</math></td> <td colspan="3">3( distance <math>\geq 10\text{mm}</math>)</td> </tr> <tr> <td><math>0.15 &lt; \Phi \leq 0.2</math></td> <td colspan="3">1</td> </tr> <tr> <td><math>0.2 &lt; \Phi</math></td> <td colspan="3">0</td> </tr> </tbody> </table>	Zone Size (mm)	Acceptable Qty			A	B	C	$\Phi \leq 0.10$	Ignore			$0.10 < \Phi \leq 0.15$	3( distance $\geq 10\text{mm}$ )			$0.15 < \Phi \leq 0.2$	1			$0.2 < \Phi$	0		
		Zone Size (mm)		Acceptable Qty																					
			A	B	C																				
		$\Phi \leq 0.10$	Ignore																						
		$0.10 < \Phi \leq 0.15$	3( distance $\geq 10\text{mm}$ )																						
		$0.15 < \Phi \leq 0.2$	1																						
		$0.2 < \Phi$	0																						
		② Dim spot ( LCD/TP/Polarizer dim dot, light leakage, dark spot ) <table border="1" data-bbox="446 884 1220 1243"> <thead> <tr> <th rowspan="2">Zone Size (mm)</th> <th colspan="3">Acceptable Qty</th> </tr> <tr> <th>A</th> <th>B</th> <th>C</th> </tr> </thead> <tbody> <tr> <td><math>\Phi \leq 0.1</math></td> <td colspan="3">Ignore</td> </tr> <tr> <td><math>0.1 &lt; \Phi \leq 0.2</math></td> <td colspan="3">2( distance <math>\geq 10\text{mm}</math>)</td> </tr> <tr> <td><math>0.2 &lt; \Phi \leq 0.3</math></td> <td colspan="3">1</td> </tr> <tr> <td><math>\Phi &gt; 0.3</math></td> <td colspan="3">0</td> </tr> </tbody> </table>	Zone Size (mm)	Acceptable Qty			A	B	C	$\Phi \leq 0.1$	Ignore			$0.1 < \Phi \leq 0.2$	2( distance $\geq 10\text{mm}$ )			$0.2 < \Phi \leq 0.3$	1			$\Phi > 0.3$	0		
		Zone Size (mm)		Acceptable Qty																					
			A	B	C																				
		$\Phi \leq 0.1$	Ignore																						
		$0.1 < \Phi \leq 0.2$	2( distance $\geq 10\text{mm}$ )																						
$0.2 < \Phi \leq 0.3$	1																								
$\Phi > 0.3$	0																								
③ Polarizer accidented spot <table border="1" data-bbox="446 1332 1220 1624"> <thead> <tr> <th rowspan="2">Zone Size (mm)</th> <th colspan="3">Acceptable Qty</th> </tr> <tr> <th>A</th> <th>B</th> <th>C</th> </tr> </thead> <tbody> <tr> <td><math>\Phi \leq 0.2</math></td> <td colspan="3">Ignore</td> </tr> <tr> <td><math>0.2 &lt; \Phi \leq 0.5</math></td> <td colspan="3">2( distance <math>\geq 10\text{mm}</math>)</td> </tr> <tr> <td><math>\Phi &gt; 0.5</math></td> <td colspan="3">0</td> </tr> </tbody> </table>	Zone Size (mm)	Acceptable Qty			A	B	C	$\Phi \leq 0.2$	Ignore			$0.2 < \Phi \leq 0.5$	2( distance $\geq 10\text{mm}$ )			$\Phi > 0.5$	0								
Zone Size (mm)		Acceptable Qty																							
	A	B	C																						
$\Phi \leq 0.2$	Ignore																								
$0.2 < \Phi \leq 0.5$	2( distance $\geq 10\text{mm}$ )																								
$\Phi > 0.5$	0																								



	Line defect (LCD/TP /Polarizer black/white line, scratch, stain)	<table border="1"> <thead> <tr> <th rowspan="2">Width(mm)</th> <th rowspan="2">Length(mm)</th> <th colspan="3">Acceptable Qty</th> </tr> <tr> <th>A</th> <th>B</th> <th>C</th> </tr> </thead> <tbody> <tr> <td><math>\Phi \leq 0.03</math></td> <td>Ignore</td> <td colspan="2">Ignore</td> <td rowspan="3">Ignore</td> </tr> <tr> <td><math>0.03 &lt; W \leq 0.05</math></td> <td><math>L \leq 3.0</math></td> <td colspan="2"><math>N \leq 2</math></td> </tr> <tr> <td><math>0.05 &lt; W \leq 0.08</math></td> <td><math>L \leq 2.0</math></td> <td colspan="2"><math>N \leq 2</math></td> </tr> <tr> <td><math>0.08 &lt; W</math></td> <td colspan="3">Define as spot defect</td> <td></td> </tr> </tbody> </table>	Width(mm)	Length(mm)	Acceptable Qty			A	B	C	$\Phi \leq 0.03$	Ignore	Ignore		Ignore	$0.03 < W \leq 0.05$	$L \leq 3.0$	$N \leq 2$		$0.05 < W \leq 0.08$	$L \leq 2.0$	$N \leq 2$		$0.08 < W$	Define as spot defect			
Width(mm)	Length(mm)	Acceptable Qty																										
		A	B	C																								
$\Phi \leq 0.03$	Ignore	Ignore		Ignore																								
$0.03 < W \leq 0.05$	$L \leq 3.0$	$N \leq 2$																										
$0.05 < W \leq 0.08$	$L \leq 2.0$	$N \leq 2$																										
$0.08 < W$	Define as spot defect																											
3.0	Polarizer bubble	<table border="1"> <thead> <tr> <th rowspan="2">Zone Size (mm)</th> <th colspan="3">Acceptable Qty</th> </tr> <tr> <th>A</th> <th>B</th> <th>C</th> </tr> </thead> <tbody> <tr> <td><math>\Phi &lt; 0.2</math></td> <td colspan="2">Ignore</td> <td rowspan="4">Ignore</td> </tr> <tr> <td><math>0.2 &lt; \Phi &lt; 0.4</math></td> <td colspan="2">2 (distance <math>\geq 10\text{mm}</math>)</td> </tr> <tr> <td><math>0.4 &lt; \Phi &lt; 0.6</math></td> <td colspan="2">1</td> </tr> <tr> <td><math>0.6 &lt; \Phi</math></td> <td colspan="2">0</td> </tr> </tbody> </table>	Zone Size (mm)	Acceptable Qty			A	B	C	$\Phi < 0.2$	Ignore		Ignore	$0.2 < \Phi < 0.4$	2 (distance $\geq 10\text{mm}$ )		$0.4 < \Phi < 0.6$	1		$0.6 < \Phi$	0							
Zone Size (mm)	Acceptable Qty																											
	A	B	C																									
$\Phi < 0.2$	Ignore		Ignore																									
$0.2 < \Phi < 0.4$	2 (distance $\geq 10\text{mm}$ )																											
$0.4 < \Phi < 0.6$	1																											
$0.6 < \Phi$	0																											
4.0	SMT	According to IPC-A-610C class II standard . Function defect and missing part are major defect ,the others are minor defect.																										

## 11. Handling Precautions

### 11.1 Mounting method

The LCD panel of AMSON TFT module consists of two thin glass plates with polarizers which easily be damaged. And since the module is so constructed as to be fixed by utilizing fitting holes in the printed circuit board.

Extreme care should be needed when handling the LCD modules.

### 11.2 Caution of LCD handling and cleaning

When cleaning the display surface, Use soft cloth with solvent [Recommended below] and wipe lightly

- Isopropyl alcohol
- Ethyl alcohol

Do not wipe the display surface with dry or hard materials that will damage the polarizer surface.

Do not use the following solvent:

- Water
- Aromatics

Do not wipe ITO pad area with the dry or hard materials that will damage the ITO patterns

Do not use the following solvent on the pad or prevent it from being contaminated:

- Soldering flux
- Chlorine (Cl), Sulfur (S)

If goods were sent without being sili8con coated on the pad, ITO patterns could be damaged due to the corrosion as time goes on.

If ITO corrosion happens by miss-handling or using some materials such as Chlorine (Cl), Sulfur (S) from customer, Responsibility is on customer.

### 11.3 Caution against static charge

The LCD module uses C-MOS LSI drivers, so we recommend that you:

Connect any unused input terminal to VDD or GND, do not input any signals before power is turned on, and ground your body, work/assembly areas, and assembly equipment to protect against static electricity.

### 11.4 Packing

- Module employs LCD elements and must be treated as such.
- Avoid intense shock and falls from a height.
- To prevent modules from degradation, do not operate or store them exposed direct to sunshine or high temperature/humidity

### 11.5 Caution for operation

- It is an indispensable condition to drive LCD's within the specified voltage limit since the higher voltage than the limit causes the shorter LCD life.
- An electrochemical reaction due to direct current causes LCD's undesirable deterioration, so that the use of direct current drive should be avoided.
- Response time will be extremely delayed at lower temperature than the operating temperature range and on the other hand at higher temperature LCD's show dark color in them. However those phenomena do not mean malfunction or out of order with LCD's, which will come back in the specified operation temperature.

- If the display area is pushed hard during operation, some font will be abnormally displayed but it resumes normal condition after turning off once.
- Slight dew depositing on terminals is a cause for electro-chemical reaction resulting in terminal open circuit.

Usage under the maximum operating temperature, 50%Rh or less is required.

## 11.6 Storing

In the case of storing for a long period of time for instance, for years for the purpose or replacement use, the following ways are recommended.

- Storage in a polyethylene bag with the opening sealed so as not to enter fresh air outside in it. And with no desiccant.
- Placing in a dark place where neither exposure to direct sunlight nor light's keeping the storage temperature range.
- Storing with no touch on polarizer surface by the anything else.

[It is recommended to store them as they have been contained in the inner container at the time of delivery from us.

## 11.7 Safety

- It is recommendable to crash damaged or unnecessary LCD's into pieces and wash off liquid crystal by either of solvents such as acetone and ethanol, which should be burned up later.
- When any liquid leaked out of a damaged glass cell comes in contact with your hands, please wash it off well with soap and water.

## 12. Precaution for Use

### 12.1

A limit sample should be provided by the both parties on an occasion when the both parties agreed its necessity. Judgment by a limit sample shall take effect after the limit sample has been established and confirmed by the both parties.

### 12.2

On the following occasions, the handing of problem should be decided through discussion and agreement between responsible of the both parties.

- When a question is arisen in this specification.
- When a new problem is arisen this is not specified in this specification.
- When an inspection specifications change or operating condition change in customer is reported to AMSON TFT and some problem is arisen in this specification due to the change.
- When a new problem is arisen at the customer's operating set for sample evaluation in the customer site.



### **13. Packing Method**

**T.D.B**